



HOW TO ASSEMBLE

YUKON™ SERIES

11x9 / 3.3x2.7 | 11x13 / 3.3x4

IMPORTANT!

Please read these instructions carefully before starting assembly.
Keep these instructions in a safe place for future reference.

www.canopia.com















11x9 / 3.3x2.7



11x13 / 3.3x4

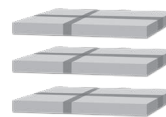

AVAILABLE MODELS

11x9 / 3.3x2.7		11x13 / 3.3x3.4		11x17 / 3.3x5.2		11x21 / 3.3x6.4	
							
PRIMARY UNIT 11x9 / 3.3x2.7	2 BOXES 	PRIMARY UNIT 11x9 / 3.3x2.7	2 BOXES 	PRIMARY UNIT 11x9 / 3.3x2.7	2 BOXES 	PRIMARY UNIT 11x9 / 3.3x2.7	2 BOXES 
		1 EXTENSION UNIT 11x4 / 3.3x0.4	1 BOX 	2 EXTENSION UNITS 11x4 / 3.3x0.4	2 BOXES 	3 EXTENSION UNITS 11x4 / 3.3x0.4	3 BOXES 
				REINFORCEMENT KIT 3 pcs	1 BOX 	REINFORCEMENT KIT 4 pcs	1 BOX 

Yukon WPC floor KIT - purchased separately

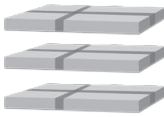
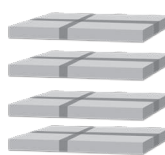
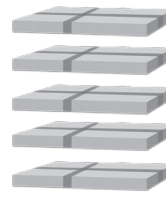
FLOOR KIT 11x9 / 3.3x2.7	2 BOXES 	FLOOR KIT 11x13 / 3.3x3.4	3 BOXES 	FLOOR KIT 11x17 / 3.3x5.2	4 BOXES 	FLOOR KIT 11x21 / 3.3x6.4	5 BOXES 
-----------------------------	---	------------------------------	--	------------------------------	---	------------------------------	---

HAVE A CONCERN? WE CAN HELP.

Before returning your purchase:

Please take a look at our
"How to Assemble" video guide.
Scan the QR Code below or go to
canopia.shop/Assemble-Yukon

You didn't find what you
were looking for?
We can help at
canopia.shop/support.

Still can't find what you
are looking for?
Please see next page for
local customer care.

HABEN SIE BEDENKEN? WIR KÖNNEN HELFEN.

Bevor Sie Ihren Kauf zurücksenden:

Schauen Sie sich bitte unsere
„Videoanleitung Zusammenbau“ an.
Scannen Sie den QR-Code unten
oder besuchen Sie
canopia.shop/Assemble-Yukon

Haben Sie nicht gefunden,
wonach Sie gesucht haben?
Unter canopia.shop/support
können wir helfen.

Sie haben noch nicht
gefunden wonach Sie suchen?
Auf der nächsten Seite
finden Sie den Kontakt zu
unserem lokalen Kundendienst.

TIENE ALGUNA INQUIETUD? PODEMOS AYUDARLE.

Antes de retornar su compra:

Por favor mire nuestro video de
montaje "How to Assemble".
Escanee el código QR abajo o
canopia.shop/Assemble-Yukon

No encontré lo que
estaba buscando?
Podemos ayudarle en
canopia.shop/support.

Aún no encontré lo que buscaba?
Por favor vea en la siguiente
página el Servicio Local al Cliente.

UN SOUCI? UNE QUESTION? NOUS POUVONS VOUS AIDER.

Avant de renvoyer ce produit:

Jetez un coup d'oeil à notre
Vidéo d'Assemblage.
Scannez le code QR ci-dessous
ou rendez vous sur
canopia.shop/Assemble-Yukon

Vous n'avez pas trouvé
ce que vous cherchez ?
Nous pouvons vous aider sur
canopia.shop/support.

Insatisfait/e ou sans réponse ?
Merci de contacter notre Service
Client local ci-dessous.





WE ARE HERE TO HELP

For general questions: canopia.com/contact-us

NORWAY • SWEDEN • ARGENTINA • GREECE • GREENLAND • ICELAND • ESTONIA • JAPAN • LATVIA • LITHUANIA
MAURITIUS • MEXICO • ROMANIA • RUSSIA • TURKEY • UZBEKISTAN • UKRAINE • SWAZILAND • KOREA

+972-4-848-6816 | customer.service@palram.com

USA	CANADA	HUNGARY • SLOVAKIA
877-627-8476 generalsupport@poly-tex.com	905-5646007 sales@footprintproducts.com	+420-493-523-523 servis@garland.cz
UNITED KINGDOM • IRELAND	GERMANY	NEW ZEALAND
01302-380775 customer.serviceUK@palram.com	0180-522-8778 customer.serviceDE@palram.com	0800 800 880 customer.service@palram.com
FRANCE • BELGIUM	ISRAEL	DENMARK
+33-169-791-094 customer.serviceFR@palram.com	04-848-6800 customer.service@palram.com	07-575 42 70 post@nshnordic.com
ITALY • NETHERLANDS • PORTUGAL • SPAIN	AUSTRIA • LUXEMBURG • LIECHTENSTEIN	SOUTH AFRICA
+33-169-791-094 customer.serviceFR@palram.com	+49-180-522-8778 customer.serviceDE@palram.com	011-397-7771 receptionza@palram.com
AUSTRALIA	AUSTRALIA - GREENHOUSES	CROATIA • SLOVENIA
03-9219-4444 salesvic@palram.com	03-9544-6-999 info@mazedistribution.com.au	0599-37-057 info@ms-viscom.com
CZECH REPUBLIC	SWITZERLAND	POLAND
0493-523-523 servis@garland.cz	062-287-33-77 info@ritter.ch	Infolinia: 801-011-929 22-349-93-36 kontakt@ogrodosfera.pl
CYPRUS	FINLAND	
0224-971-13 alpaco@alpacodomatica.com www.alpacodomatica.com	Neuvonta: 09-6866720 Tuki / Varaosat: 050-3715350 www.horizontenterprises.fi tuki@horizontenterprises.fi	

BASE DIMENSIONS YUKON

MODEL	11x9 / 3.3x2.7	
	11x13 / 3.3x4	
WIDTH	A	307 cm / 121"
LENGTH	B	257 cm / 101.2"
		381 cm / 150"

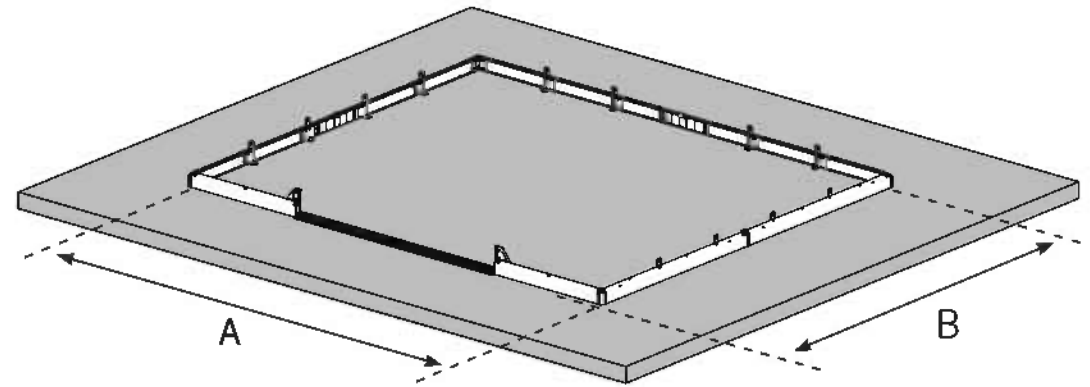

TOOLS & EQUIPMENT

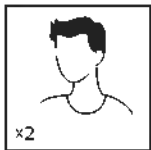

2 people needed



Work gloves

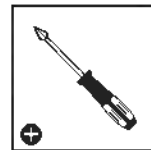

Philips head
Screwdriver



Silicone



Wrench
10 mm | 13/32"

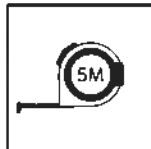

Tape Measure



Cordless drill
Phillips head

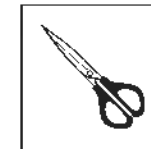

Scissors



Soap



Ladder

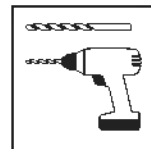

Cordless drill
With Drill Bit



Jigsaw
(WPC Floor Kit)

SITE PREPARATION & FOUNDATION

A - PREPARE THE SITE

The product must be positioned and fixed on a flat level surface.

① - Clear the site



② - Level the ground

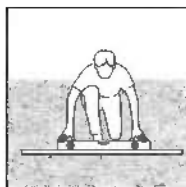

	A	①	②
FR	PRÉPARER LE TERRAIN Le produit doit être positionnée et fixée sur une surface plane	Déblayer le terrain	Niveler le sol
DE	VORBEREITUNG DES UNTERGRUNDES Das Produkt muss auf einem flachen Untergrund aufgestellt und befestigt werden.	Standort säubern	Untergrund ausgleichen und nivellieren
ES	PREPARE EL SITIO El producto debe colocarse y fijarse en una superficie plana y nivelada.	Limpie el sitio	Nivele el terreno
SV	FÖRBEREDA OMRÅDET Produkt måste placeras på en fast och plant underlag.	Rensa området	Platta marken
NN	FORBERED OMRÅDET Produkt må plasseres og festes på et flatt underlag.	Rydd området	Flat ut bakken
FI	VALMISTELE RAKENNUSALUE Pinnan on oltava täysin tasainen ja suora, ja perustan oltava kiinteä.	Raivaa rakennusalue	Tasoita maa
DA	FORBERED OMRÅDET Produkt skal placeres og opføres på en plan flade.	Ryd stedet	Gør jorden jævn
NL	TERREIN VOORBEREIDEN Het grondoppervlak moet perfect vlak en waterpas zijn.	Maak het terrein vrij	Egaliseer de grond
IT	PREPARARE IL SITO Il prodotto deve essere posizionato e fissato su una superficie piana.	Sgombrare il sito	Livellare il terreno
HE	הכן את האתר את המוצר יש להקים על קרקע יציבה ומסולסת בכדי שהוא יתפקד כראוי.	פנה את האתר	פלט את הקרקע

B - CHOOSE YOUR FOUNDATION TYPE

For a foundation, we recommend using three material types :
Concrete / Pressure treated wood / wood deck / Paver blocks

Solid base

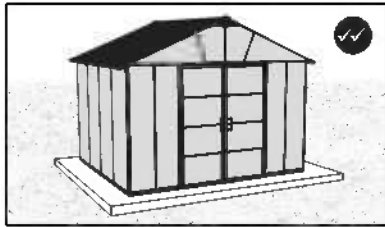
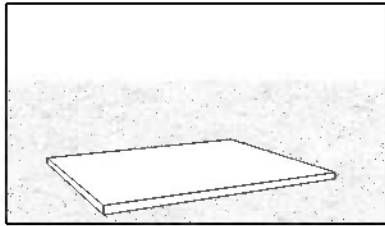

Not possible

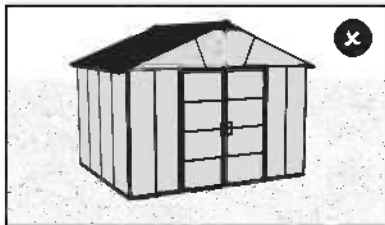
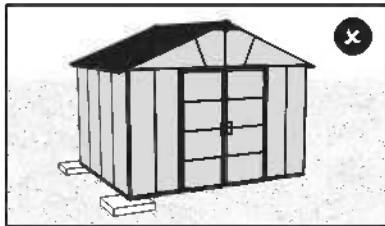

* The size of the product displayed is for illustration purposes only and may not reflect the size of your product.

	B	Solid foundation Preferred ✓	Not possible ✗
FR	<p>CHOISIR VOTRE TYPE DE FONDATION Pour la fondation, nous recommandons d'utiliser trois types de matériaux : Béton / Bois traité sous pression / plancher en bois / Blocs de pavés. * La taille du la produit affichée ici est uniquement à titre d'illustration et ne reflète pas forcément la taille de votre produit.</p>	Une base solide Recommandé	Pas possible
DE	<p>FUNDAMENTWAHL Als Fundament stehen folgende Materialien zur Auswahl (Empfehlung): Beton / Druckbehandeltes Holz / Holzdeck / Pflastersteine. * Die Größe des abgebildeten Produkt dient nur zur Veranschaulichung und entspricht möglicherweise nicht der Größe Ihres Produkt.</p>	Fester Untergrund Optimal	Nicht möglich
ES	<p>ELIJA EL TIPO DE CIMENTACIÓN Como cimentación, recomendamos usar tres tipos de materiales: Hormigón / Madera prensada / Piso de madera / Adoquín de hormigón. * El tamaño del producto que se muestra tiene un propósito meramente ilustrativo y puede no reflejar el tamaño de su producto.</p>	Base sólida Preferido	No es posible
SV	<p>VÄLJ GRUNDTYP Som stiftelse rekommenderar vi tre typer av material: Betong / Tryckbehandlat trä / trågolv / Beläggningssten * produkt storlek är endast för att illustrera och visar inte rätt storlek på ditt produkt.</p>	solid bas Föredraget	Omöjligt
NN	<p>VELG FUNDAMENTTYPE Som fundament anbefaler vi tre typer materiell: Betong Trykkbehandlet tre/tredekke Belegningsstein * produktets størrelse er bare for illustrasjon, og viser ikke korrekt størrelse på ditt produkt.</p>	Solid base Foretrukket	Ikke mulig
FI	<p>VALITSE RAKENNUSPOHJAN TYYPII Rakennuspohjaksi suosittellemme kolmea materiaalityyppiä: Betoni Painekäsitelty puu/puukansi Kiveyelementit * Esillä olevan tuote koko on tarkoitettu vain havainnollistamistarkoituksiin eikä se välttämättä vastaa tuote kokoa.</p>	Kiinteä rakennuspohja Suositeltu	Ei mahdollinen
DA	<p>VÆLG DIN FUNDAMENTTYPE Til en fundament anbefaler vi at bruge tre materialer: Beton / Trykbehandlet træ / trædek / Udlægningsblokke * Størrelsen på det viste produkt er kun til illustration og afspejler muligvis ikke størrelsen på dit produkt.</p>	Solid base Foretrukket	Ikke muligt
NL	<p>KIES UW TYPE FUNDERING Als fundering adviseren wij drie materiaalsoorten te gebruiken: Beton Onder druk behandeld hout/houten dek Bestratingblokken * De grootte van de getoonde Product dient enkel ter illustratie en weerspiegelt mogelijk niet de grootte van uw eigen Product.</p>	Massieve basis Voorkeur	Niet mogelijk
IT	<p>SCEGLIERE IL TIPO DI FONDAZIONE Come fondamenta consigliamo tre tipi di materiali: Calcestruzzo / Legno pressato / Pavimenti in legno / Calcestruzzo per pavimentazioni. * La dimensione della Prodotto visualizzata è solo a scopo illustrativo e potrebbe non rispecchiare le dimensioni della vostra Prodotto.</p>	Fondamenta solide Preferito	No possible
HE	<p>בחר את סוג היסודות שלך במור בסיס או ממליצים לעשות שימוש בשלושה סוגי חמרים: בטון עץ שעבר טיפול הקשייה/דק עץ בלוקים לריצוף. * גודל המוצר המוצג הינו להדגמה בלבד ולא מייצג את גודל המוצר שלכם.</p>	בסיס מוצק מועדף	בלתי אפשרי

C - ANCHOR TO FOUNDATION

1 - On a solid base

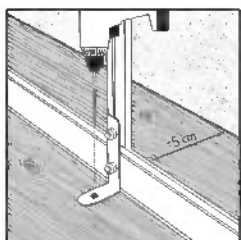
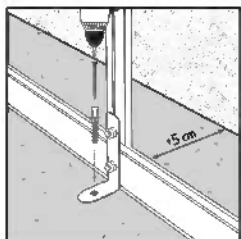

* Secure the product to the foundation of your choice using suitable screws & plugs or masonry anchors (not supplied).

Make sure you have at least 5 cm / 2" between the product base and the edges of your foundation - **on all sides.**

	C	1	*
FR	ANCRAGE A LA FONDATIO	Sur une base solide	Fixez le produit à la fondation de votre choix, à l'aide de vis et de chevilles appropriées ou d'ancrages en maçonnerie (non fournis). Assurez-vous qu'il y a au moins 5 cm entre la base du produit et le périmètre de votre fondation - de tous les côtés.
DE	BEFESTIGUNG AM FUNDAMENT	Befestigen Sie das Produkt auf einem festen Untergrund	Mit geeigneten Dübeln und Schrauben oder Mauerwerksankern, je nach gewähltem Fundamenttyp (nicht mitgeliefert). Stellen Sie sicher, dass zwischen der Basis des Produkts und den Kanten Ihres Fundaments auf allen Seiten mindestens 5 cm Abstand sind.
ES	ANCLAJE A LOS CIMIENTOS	Sobre una base sólida	Asegure el producto a los cimientos de su elección, usando tornillos y tacos adecuados o andajes de mampostería (no suministrados). Asegúrese de tener al menos 5 cm 2" entre la base del producto y el perímetro de su cimiento - en todos los lados.
SV	FEST FÖR STIFTELSE	På en solid bas	Asegure el producto a los cimientos de su elección, usando tornillos y tacos adecuados o andajes de mampostería (no suministrados). Se till att du har minst 5 cm 2" mellan produktens bas och kanterna på fundamente - på alla sidor.
NN	FEST TIL FUNDAMENT	På en solid base	Sikrer du produktet til fundamentet du har valgt med passende skruer, plugger eller murfester (ikke inkludert). Forsikre deg om at du har minst 5 cm 2" mellom bunnen av produktet og kantene på fundamentet ditt - på alle sider.
FI	RAKENNUSPOHJAN ANKKURI	Kiinteälle rakennuspohjalle	Mikäli tuote rakennetaan kiinteälle rakennuspohjalle, kiinnitä tuote valitsemaasi rakennuspohjaan sopivilla ruuveilla & tapella tai muurausankkureilla (ei sisälly toimitukseen). Varmista, että sinulla on vähintään 5 cm 2" tilaa tuotteen alustan ja perustuksen reunojen välillä - kaikilla puollilla.
DA	FASTGØRELSE TIL FUNDAMENTET	På et solidt underlag	Skal du fastgøre produktet til det fundament, du vælger, ved hjælp af passende skruer & stik eller murankre (medfølger ikke). Skal du sørge for at have mindst 5 cm 2" mellem produktrammen og kanterne på dit fundament - på alle sider.
NL	VERANKERING AAN FUNDERING	Op een stevige fundering	Zet het product op een stevige basis vast op de fundering van uw keuze, met geschikte schroeven & pluggen of metselwerkankers (niet meegeleverd). Zorg ervoor dat u minstens 5 cm hebt tussen de basis van het product en de randen van uw fundering - langs alle kanten.
IT	ANCORAGGIO ALLE FONDAMENTA	Su fondamenta solida	Fissare il prodotto delle fondamenta di vostra scelta, utilizzando viti e tasselli adeguati o ancoraggi in muratura (non forniti). Assicuratevi di avere almeno 5 cm tra la base del prodotto e i bordi del tuo fondotinta - su tutti i lati.
HE	עגן את הבסיס	על בסיס מוצק	חבר את המוצר לבסיס (יסוד) שבחרת והשתמש בברגים מתאימים וסגרים, או עוגני בנאות (לא סופקו). ודאו שיש לכם לפחות 5 סמ' בין מסגרת המוצר וקצות הבסיס (היסוד) - בכל הצדדים.

D - OPTIONELE ACCESSOIRES

① WPC FLOOR KIT:

If you've purchased the WPC Floor Kit with the product, relevant steps are marked with these icons.

If you've assembled the product without the floor kit and wish to add one, please refer to the relevant steps (marked with these icons) in the assembly and perform the necessary adjustments.

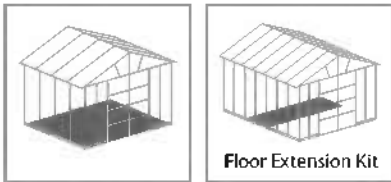

② UTILITY SHED SHELF KIT:

If you've purchased shelf kits, it is recommended to insert screws #411 inside the profiles' tracks during the walls' assembly.

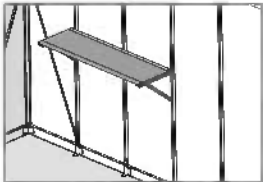

③ VERTICAL BICYCLE HANGER:

Can be installed once the product is fully assembled. Make sure the bottom wheel is at floor level.

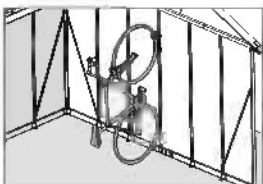

	D	①	②	③
FR	OPTIONALES ZUBEHÖR	WPC FLOOR KIT: Si vous avez acheté le sol en kit avec le produit, les étapes correspondantes sont symbolisées par cette icône. Si vous avez assemblé le produit sans sol en kit, et souhaitez en ajouter un, veuillez-vous reporter aux étapes appropriées du montage et effectuer les ajustements nécessaires.	KIT DE ÉTAGÈRE: Si vous avez acheté des kits de étagère, il est recommandé d'insérer des vis # 411 à l'intérieur des rails des profilés lors de l'assemblage des murs.	CINTRE À BICYCLETTE VERTICALE: Peut être installé une fois que le produit est complètement assemblé. Assurez-vous que la roue inférieure est au niveau du sol.
DE	OPTIONALES ZUBEHÖR	WPC FLOOR KIT: Wenn Sie auch das Boden-Set mit dem Produkt gekauft haben, sind die entsprechenden Schritte mit diesem Symbol gekennzeichnet. Wenn Sie das Produkt ohne dem Bodenset montiert haben und es später hinzufügen möchten, so beachten Sie bitte die entsprechenden Schritte in der Montage und führen Sie die notwendigen Änderungen durch.	REGAL KIT: Wenn Sie Regal Kits gekauft haben, wird empfohlen, die Schrauben Nr. 411 während der Wandmontage in die Innenseite der Schienen-Profile einzusetzen.	VERTIKALE FAHRRADHALTERUNG: Kann erst installiert werden, wenn das Produkt vollständig montiert ist. Vergewissern Sie sich, dass sich das untere Rad auf Bodenhöhe befindet.
ES	ACCESORIOS OPCIONALES	WPC FLOOR KIT: Si ha comprado el kit de piso con el producto, los pasos relevantes están marcados con este icono. Si ha ensamblado el producto sin el kit de piso y desea agregar uno, consulte los pasos correspondientes en el ensamblaje y realice los ajustes necesarios.	JUEGO DE ESTANTERÍA: si ha comprado juegos de estante, se recomienda insertar tornillos # 411 dentro de las guías de los perfiles durante el montaje de las paredes.	SUSPENSIÓN VERTICAL PARA BICICLETAS: se puede instalar una vez que el producto esté completamente ensamblado. Asegúrese de que la rueda inferior esté al nivel del piso.
SV	VALFRJA TILLBEHÖR	WPC GOLV-KIT: Om du har köpt ett golv-kit med produkten markeras relevanta steg med dessa ikoner. Om du har monterat produkten utan golv-kitet och vill lägga till det, vänligen se de relevanta stegen (markerade med dessa ikoner) i monteringen och utför de nödvändiga justeringarna.	VERKTYGSSKJUL HYLL-KIT: Om du har köpt hyll-kit rekommenderas att du sätter in skruvarna # 411 inuti profilers spår när väggarna monteras.	VERTIKAL CYKELHÄNGARE: Kan installeras när produkten är helt monterad. Se till att bottenhjulet är på golvnivå.
NN	VALGRITT TILBEHØR	WPC FLOOR KIT: Hvis du kjøpte gulvsettet med produktet, er de aktuelle trinnene merket med dette ikonet. Hvis du har montert produktet uten gulvsettet og ønsker å legge det til, se de aktuelle trinnene i håndboken og gjør nødvendige justeringer.	HYLLESETT: Hvis du har kjøpt hyllesett, anbefales det å feste skruene (# 411) i profilsporene under veggmonteringen.	VERTIKALT SYKKELSTATIV: Kan installeres når produktet er ferdig montert. Pass på at det nederste hjulet er på gulvnivå.
FI	VALINNAISET LISÄVARUSTEET	WPC-LATTIASARJA: Jos olet hankkinut lattiasarjan tuoteeseen, niin siihen liittyvät vaiheet on merkitty näillä kuvakkeilla. Jos olet koennut tuotteen ilman lattiasarjaa ja haluat lisätä sen, katso (näillä kuvakkeilla merkittyjä) asiaan liittyviä vaiheita kokoamisesta, ja tee tarvittavat säädöt.	TARVIKEVAJA-HYLLYSARJA: Jos olet hankkinut hyllysarjan, niin suositellaan ruuvien # 411 asettamista profiilien urien sisälle seiniä kootaessa.	PYSTYSUORA POLKUPYÖRÄTELINE: Voidaan asentaa, kun tuote on täysin koottu. Varmista, että alempi pyörä on lattian tasolla.
DA	OPTIONAL ACCESSORIES	WPC GULVSÆT: Hvis du har købt gulvsættet sammen med produktet, er relevante trin markeret med disse ikoner. Hvis du har monteret produktet uden gulvsættet og ønsker at tilføje et, henvises der til de relevante trin (markeret med disse ikoner) i monteringen og udfør de nødvendige justeringer.	HYLDESÆT TIL SKUR: Hvis du har købt hyldesæt, anbefales det at indsætte # 411 skruerne i profilens skinne under vægmontering.	LØDRET CYKLOPHÆNG: Kan monteres, når produktet er fuldt monteret. Sørg for, at bundhjulet er i gulvniveau.
NL	OPTIONELE ACCESSOIRES	WPC-VLOERKIT: Als u de vloerkit bij het product hebt gekocht, zijn de relevante stappen gemarkeerd met deze pictogrammen. Als u het product hebt geassembleerd zonder de vloerkit en er een wilt toevoegen, raadpleegt u de relevante stappen (gemarkeerd met deze pictogrammen) in de assembly en voer de nodige aanpassingen uit.	SCHAPPENSSETS: Als u schappensets hebt gekocht, wordt het aanbevolen om schroeven # 411 in de profielen te plaatsen tijdens de montage van de wanden.	VERTICALE FIETSHANGER: Kan worden geïnstalleerd als het product volledig is gemonteerd. Zorg ervoor dat het onderste wiel op vloerniveau staat.
IT	ACCESSORI OPTIONAL	KIT PAVIMENTO WPC: se hai acquistato il kit pavimento con il prodotto, i passaggi pertinenti sono contrassegnati da queste icone. Se hai assemblato il prodotto senza il kit pavimento e desideri aggiungerne uno, fai riferimento ai passaggi pertinenti (contrassegnati con queste icone) nell'assieme ed eseguire le regolazioni necessarie.	KIT SCAFFALE: se hai acquistato i kit di scaffali, è consigliabile inserire le viti n.411 all'interno delle tracce dei profili durante l'assemblaggio delle pareti.	PORTABICI VERTICALE: può essere installato una volta che il prodotto è completamente assemblato. Assicurati che la ruota inferiore sia a livello del pavimento.
HE	אביזרים אופציונליים	ערכת רצפת WPC אם רכשת את ערכת הרצפה עם המוצר, השלבים הרלוונטיים מסומנים בסמלים אלו. אם הרכבת את המוצר ללא ערכת הרצפה ואתה מעוניין להוסיף כזו, אנא פנה לשלבים הרלוונטיים (המסומנים בסמלים אלו) בהרכבה ובצע את ההתאמות הנדרשות.	ערכת מדף למחסן: אם רכשת ערכת מדפים, מומלץ להכניס את ברגי #411 לתוך מסלולי המוצר בעת ההרכבה של קיר המחסן.	מתלה אופניים אנכי: ניתן להתקנה לאחר הרכבתו המלאה של המוצר. יש לוודא שהגלגל התחתון הוא בטובה הרצפה.

E - IMPORTANT!

①

The drawings in this manual are designed for products 11x9 / 3.3x2.7 & 11x13 / 3.3x4.

②

If you've purchased Yukon 11x17 / 3.3x5.2 or 11x21 / 3.3x6.4, you will find the relevant assembly instructions in the **Reinforcement Kit**.

	E	①	②
FR	IMPORTANTE!	Les dessins de ce manuel correspondent à un produit 11x3.3 / 9x11 & 2.7x3.3 / 13x4.	Si vous avez acheté Yukon 11x3.3/17x5.2 ou 11x3.3/21x6.4, vous allez trouver les instructions de montage appropriées dans le kit de renfort .
DE	WICHTIGE!	Die Zeichnungen in diesem Handbuch beziehen sich für den 11x3.3 / 9x11 & 2.7x3.3 / 13x4 Schuppen.	Wenn Sie einen Yukon 11x3.3/17x5.2 oder 11x3.3/21x6.4 gekauft haben, finden Sie die entsprechenden Montageanleitungen im Reinforcement Kit .
ES	IMPORTANTE!	Los dibujos en este manual están diseñados para cobertizos de 11x3.3/9x11 & 2.7x3.3/13x4.	Si ha comprado el modelo Yukon de 11x3.3/17x5.2 u 11x3.3/21x6.4, encontrará las instrucciones de montaje adecuadas, en el Kit de Refuerzo .
SV	VIKTIG!	Ritningarna i den här manualen är konstruerade för 11x3.3 / 9x11 & 2.7x3.3/13x4 produkten.	Om du har köpt Yukon 11x3.3/17x5.2 <u>o</u> 11x3.3/21x6.4, hittar du de relevanta monteringsanvisningarna i förstärkningsatsen .
NN	VIKTIG!	Tegningene i denne håndboken er laget for produktets 11x3.3 / 9x11 & 2.7x3.3/13x4.	Hvis du har kjøpt Yukon 11x3.3/17x5.2 <u>o</u> 11x3.3/21x6.4, finner du de relevante monteringsinstruksjonene i forsterkningssettet .
FI	TÄRKEÄ!	ämän piirustuksen kuvat on suunniteltu tuotteelle 11x3.3 / 9x11 & 2.7x3.3 / 13x4.	Jos olet ostanut Yukon 11x3.3 / 17x5.2 <u>o</u> 11x3.3 / 21x6.4, löydät asiaankuuluvat kokoonpano-ohjeet vahvistussarjasta .
DA	VIKTIG!	Tegningerne i denne vejledning er designet til produktet 11x3.3 / 9x11 & 2.7x3.3 / 13x4.	Hvis du har købt Yukon 11x3.3 / 17x5.2 <u>o</u> 11x3.3 / 21x6.4, finder du de relevante monteringsinstruktioner i forstærkningsættet .
NL	BELANGRIJK!	De tekening in deze handleiding zijn ontworpen voor 11x3.3 / 9x11 & 2.7x3.3 / 13x4 -product.	Als u Yukon 11x3.3 / 17x5.2 <u>o</u> 11x3.3 / 21x6.4 hebt gekocht, vindt u de relevante montage-instructies in de versterkingskit .
IT	IMPORTANTE!	I disegni in questo manuale sono progettati per un prodotti 11x3.3 / 9x11 & 2.7x3.3 / 13x4.	Se hai acquistato Yukon 11x3.3 / 17x5.2 o 11x3.3 / 21x6.4, troverai le relative istruzioni di montaggio nel kit di rinforzo .
HE	חשוב	האיורים במדריך זה מתאימים למוצרים: 11x13/3.3x4 או 11x9/3.3x2.7.	במידה ורכשתם יוקון 11x17/3.3x5.2 או 11x21/3.3x6.4 תמצאו את הוראות ההרכבה הרלוונטיות בארזות ערכת החיזוק .

SAFETY ADVICE

- It is of utmost importance to assemble all of the parts according to the directions. Do not skip any steps.
- Always wear work gloves during panel sliding.
- Always wear shoes and safety goggles when working with extruded aluminium.
- If using a step ladder or power tools make sure that you follow the manufacturer's safety advice.
- Do not touch overhead power cables with the aluminium profiles.
- Do not attempt to assemble the product in windy or wet conditions.
- Dispose of all plastic bags. Keep them out of reach of small children.
- Keep children away from the assembly area.
- Do not lean against or push the products during construction.
- Do not position your product in an area exposed to excessive winds.
- Do not attempt to assemble this product if you are tired, have taken drugs or alcohol or if you are prone to dizzy spells.
- Hot items such as recently used grills, blowtorches etc. must not be stored in the product.
- Make sure there are no hidden pipes or cables in the ground before anchoring to foundation.
- This product is designed to be used mainly as a garden shed.
- To prevent water from seeping through the floor, the product must be mounted on a raised surface from the ground.
- **Make sure to anchor the product directly to a solid foundation to increase the product's stability and wind resistance in areas with severe weather conditions. Make sure that there are no obstructions between the assembly area and the final position of the product. The Palram - Canopia Anchoring kit is available for purchase separately.**

CARE & MAINTENANCE

- When your product needs to be cleaned, use a soft cloth and rinse with cold clean water.
- DO NOT use acetone, abrasive cleaners or other special detergents to clean the panels.
- Clean the product once assembly is complete.

BEFORE ASSEMBLY

- Selecting a site:
 - Choose your site carefully before beginning assembly.
 - Choose a sunny position away from overhanging trees.
 - The product must be positioned and fixed on a flat level surface.
- The product must be secured directly to a solid foundation.
- This is a multi-part assembly best achieved by two people. Allow at least half a day for the assembly process.
- Take all components & parts out of the packages. Sort the parts and check against the content parts list.
- Parts should be laid out close at hand. Keep all small parts (screws etc.) in a bowl so they do not get lost.
- Please note multi-sided profiles are used in this product. As a result some holes in the profiles are not used during assembly.
- Please review entire instructions before starting. Carry out the assembly steps in exact order.
- Please consult your local authorities if any permits are required prior to constructing the product.
- Please ensure you have sufficient side space for inserting the roof panels during the assembly process.

IMPORTANT!

- Firmly connect the product to a level surface immediately after completion of the assembly.
 - Anchoring this product to the ground is essential to its stability and rigidity. It is required to complete this stage in order for your warranty to be valid.
 - During assembly use a soft surface below the parts to avoid scratches and damages.
 - We recommend checking for restrictions or covenants for building this product in your area.
- In addition we advise to check if you need to submit any forms or if any permit is required prior to building the product.

DURING ASSEMBLY

During assembly, you will encounter different icons for different products. Please see below for more information:



You may use silicone lubricant spray on the frame in order to help you slide the panels into the profiles. Do not spray the panels.



Use a rubber mallet if necessary.

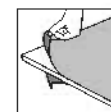

Make sure you remove covering plastic film from both sides of the panel.

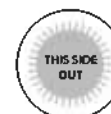

All panels with the stamped words "THIS SIDE OUT" must be facing out to create full UV protection. Remove plastic sticker as panels are locked in place.



This icon indicates that the installer should be inside the product.



This icon indicates that the installer should be outside the product.



Steps marked with dashed outlines refer to Extensions only. Some of the steps are irrelevant for an assembly of a single product. When assembling a single or an extended product, some parts may be surplus.



These 2 icons below indicate if screw's tightening is required or not.



Temporary tightening of a few screws may be needed to prevent a profile from sliding out. Tighten all screws once assembly is completed.

CONSEILS DE SECURITE

- Très important ! Veuillez suivre scrupuleusement les instructions de ce manuel et réaliser les étapes dans l'ordre énoncé.
- Nous recommandons vivement le port de gants de protection pendant le montage
- Portez toujours des chaussures de travail et des lunettes de protection lorsque vous travaillez des pièces en aluminium extrudé
- Lors de l'utilisation d'une échelle ou d'outils électriques, assurez-vous de bien suivre les consignes de sécurité du fabricant.
- Veillez à ne pas toucher de câbles aériens avec les profilés en aluminium.
- N'essayez pas de monter la produit s'il y a du vent ou s'il fait humide.
- Jetez tous les sacs en plastique en appliquant les règles de sécurité et maintenez-les hors de portée des jeunes enfants
- Eloignez les enfants de la zone d'assemblage.
- Ne vous appuyez pas contre la produit et ne la poussez pas pendant le montage
- Ne positionnez pas la produit dans un endroit trop exposé au vent.
- N'essayez pas de monter la produit si vous êtes fatigué, si vous êtes sous l'effet de drogues, de médicaments ou d'alcool ou encore si vous êtes sujet aux vertiges.
- Les objets chauds tels qu'un barbecue, un chalumeau ou autre article ayant été récemment utilisés, ne doivent pas être rangés dans la produit.
- Assurez-vous qu'il n'y a pas de tuyaux ou de câbles cachés dans le sol avant d'ancrer à la fondation.
- Ce produit a été conçu pour être principalement utilisé comme abris de jardin.
- Pour éviter que le produit ne s'infilte par le sol, le produit doit être monté sur une surface surélevée par rapport au sol.
- **Assurez-vous d'ancrer le produit directement sur une surface solide pour augmenter sa stabilité et sa résistance au vent, en particulier dans les zones soumises à des conditions météorologiques extrêmes. Veillez à ce qu'il n'y ait pas d'obstacles entre la zone de montage et la position finale du produit. Le kit d'ancrage Palram - Canopia est disponible à l'achat séparément.**

ENTRETIEN & MAINTENANCE

- Pour nettoyer votre produit, utilisez un chiffon doux et rincez à l'eau claire et froide.
- NE PAS utiliser d'acétone ni de produits nettoyants ou autres détergents spéciaux pour nettoyer les panneaux clairs
- Nettoyez le produit une fois le montage termine

AVANT L'ASSEMBLAGE

- Choisir un endroit :
 - Choisissez votre site avec soin avant de commencer l'assemblage.
 - Choisissez un endroit ensoleillé loin des arbres en saillie
 - La produit doit être positionnée et fixée sur une surface plane.
- La produit doit être fixé directement sur une surface solide
- Il s'agit d'un assemblage multi parties qu'il vaut mieux réaliser à deux. Comptez au moins une demi journée pour le processus de montage.
- Retirez tous les composants des paquets. Triez les éléments et vérifiez la liste.
- Les éléments doivent se trouver à portée de main. Gardez tous les petits éléments (vis etc.) dans un bol pour ne pas les perdre.
- Veuillez noter que des coupes multi faces sont utilisées dans cette produit. C'est pourquoi certains trous dans les coupes ne sont pas utilisés pendant le montage.
- Veuillez vérifier toutes les instructions avant de commencer. Procédez aux étapes de montage dans l'ordre exact.
- Veuillez consulter les autorités locales au cas où des permis sont nécessaires pour la construction du produit.
- Veuillez vous assurer que vous disposez d'un espace latéral suffisant pour insérer les panneaux de toit pendant le processus d'assemblage.

IMPORTANTE!

- Connectez du produit fermement à une surface nivelée après l'achèvement de l'assemblage.
- L'ancrage du produit au sol est essentielle à sa stabilité et à sa rigidité, il est de plus nécessaire pour assurer la validité de votre garantie.
- Pendant le montage, placez une surface souple sous les pièces pour éviter de les érafler ou de les endommager.
- Avant d'assembler ce produit dans votre région, nous vous recommandons de vous renseigner sur les restrictions ou réglementations locales. Nous vous conseillons en outre de vérifier si vous devez soumettre des formulaires ou si un permis est requis avant de monter le produit.

DURANT L'ASSEMBLAGE

Lors du montage, vous trouverez différentes icônes correspondant à différents produits. Pour de plus amples informations, veuillez vous référer à ce qui suit:



Vous pouvez utiliser un spray de lubrifiant pour silicone afin de vous aider à glisser les panneaux dans les profilés. Ne pulvérisez pas les panneaux.

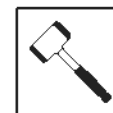

Utilisez un maillet en caoutchouc si nécessaire.

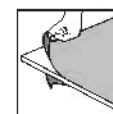

Assurez-vous de retirer le film plastique couvrant des deux côtés du panneau.



Tous les panneaux estampillés "THIS SIDE OUT" doivent être orientés vers l'extérieur pour assurer une protection UV intégrale. Retirez les stickers en plastique quand les panneaux sont verrouillés et bien en place.



Cette icône indique que l'installateur doit être à l'intérieur du produit.



Cette icône indique que l'installateur doit être en dehors du produit.



Les étapes marquées en pointillés ne concernent que les extensions. Certaines étapes ne sont pas nécessaires pour l'assemblage d'un produit unique. Lors de l'assemblage d'un produit unique ou d'une extension, il peut rester des pièces.



Ces 2 icônes indiquent s'il est nécessaire de serrer les écrous ou non. Il peut être nécessaire de serrer temporairement certaines vis pour empêcher un profilé de se déplacer. Serrez toutes les vis une fois l'assemblage terminé.

SICHERHEITSHINWEISE

- Es ist sehr wichtig, dass alle Teile gemäß den Anweisungen in dieser Anleitung zusammengebaut werden. Lassen Sie bitte keinen Schritt aus.
- Tragen Sie bei der Montage unbedingt Arbeitshandschuhe. Wir empfehlen Ihnen außerdem dringend, festes Schuhwerk und eine Schutzbrille zu tragen.
- Achten Sie beim verwenden einer Leiter oder Elektrowerkzeug bitte auf die jeweiligen Sicherheitshinweise des Herstellers.
- Berühren Sie mit den Aluminiumprofilen keine Oberleitungen.
- Halten Sie Kinder vom Aufbaubereich fern.
- Die Montage darf nur bei trockenem und windstillem Wetter erfolgen.
Entsorgen Sie alle Plastikbeutel sicher und bewahren sie außerhalb der Reichweite von Kleinkindern auf.
- Während des Aufbaus sollten Sie sich nicht gegen das Produkt lehnen oder Druck ausüben.
- Suchen Sie einen windgeschützten Standort für das Produkt aus.
- Versuchen Sie nicht, dieses Produkt zu montieren, wenn Sie müde sind, Drogen oder Alkohol zu sich genommen haben oder zu Schwindelanfällen neigen.
- Heiße Gegenstände wie kürzlich benutzte Grills, Lötlampen usw. dürfen nicht im Produkt gelagert werden.
- Bevor Sie das Produkt im Fundament verankern, vergewissern Sie sich, dass sich dort keine versteckten Rohre oder Kabel befinden.
- Dieses Produkt ist hauptsächlich für die Verwendung als Gerätehäuser vorgesehen.
- Um zu verhindern, dass Wasser durch den Boden sickert, muss das Produkt auf einer vom Boden etwas erhöhten Fläche montiert werden.
- **Um die Stabilität und Windbeständigkeit des Produkts zu erhöhen, müssen Sie es direkt auf einem soliden Fundament verankern, insbesondere in solchen Gegenden, in denen die Witterungsbedingungen streng sind. Stellen Sie sicher, dass sich keine Hindernisse zwischen dem Montagebereich und der endgültigen Position des Produkts befinden. Der Palram - Canopia - Verankerungssatz kann separat erworben werden.**

PFLEGE & WARTUNG

- Wenn Ihr Produkt gereinigt werden muss, verwenden Sie ein weiches Tuch und spülen Sie es mit kaltem, klarem Wasser ab.
- Verwenden Sie zur Reinigung der Paneele KEIN Aceton und auch keine scheuernden Reinigungsmittel oder Spezialreiniger.
- Säubern Sie das Produkt nach dem Aufbau.

VOR DEM ZUSAMMENBAU

- Die Standortwahl:
 - Wählen Sie Ihren Standort sorgfältig, bevor Sie mit dem Aufbau beginnen
 - Das Produkt muss auf einem flachen Untergrund aufgestellt und befestigt werden.
 - Wählen Sie eine Position abserts von überhängenden Bäumen
- Das Produkt muss direkt auf einem festen Untergrund befestigt werden.
- Für die Montage dieses Produktes sind zwei Personen erforderlich. Sie sich für den Zusammenbau mindestens einen halben Tag Zeit.
- Packen Sie die Bauteile aus und überprüfen Sie, ob alle Teile der Liste aufgeführt sind.
- Die Teile sollten griffbarer ausgelegt werden. Bewahren Sie alle kleinen Teile (Schrauben usw.) in einer Schüssel auf, damit nichts verloren geht.
- Beachten Sie bitte, dass bei diesem Produkt mehrseitige Profile verwendet werden. Während des Zusammenbaus sind daher nicht alle Löcher in den Profilen relevant.
- Lesen Sie vor Beginn des Aufbaus die gesamte Anleitung durch. Führen Sie die Montageschritte in genauer Reihenfolge durch.
- Fragen Sie bei den örtlichen Behörden nach, ob es irgendwelche Einschränkungen für den Aufbau gibt oder Genehmigungen erforderlich sind.
- Bitte stellen Sie sicher, dass Sie zum Einfügen der Dachplatten während des Montageprozesses ausreichend Seitenraum haben.

WICHTIG!

- Befestigen Sie das Produkts sofort nach Fertigstellung der Montage auf einem ebenen Untergrund.
- Die Verankerung dieses Produkts im Boden ist für seine Stabilität und Standfestigkeit unerlässlich. Eine ordentlich Befestigung ist erforderlich, damit die Garantie gültig ist.
- Legen Sie während des Aufbaus eine weiche Unterlage unter die einzelnen Teile, um Kratzer und Schäden zu vermeiden.
- Bevor Sie mit der Montage beginnen, vergewissern Sie sich bitte beim zuständigen Bauamt, ob es in Ihrer Region Einschränkungen oder Auflagen für den Bau des gewählten Produktes gibt. Wir bitten Sie außerdem zu prüfen, ob eine Genehmig für den Bau erforderlich ist.

DURING ASSEMBLY

Während der Montage werden Sie verschiedene Symbole für unterschiedliche Produkte sehen. Weitere Informationen finden Sie unten:



Sie können Silikonschmierspray auf den Rahmen sprühen, um das Einschieben der Platten in die Profile zu erleichtern. Besprühen Sie nicht die Platten



Nehmen Sie – falls nötig – einen Gummihammer zur Hilfe

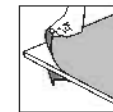

Sie die abdeckende Kunststoffolie von beiden Seiten der Verkleidung entfernen.



Alle mit den Worten "THIS SIDE OUT" versehenen Platten müssen nach außen zeigen, um den vollen UV-Schutz zu gewährleisten. Entfernen Sie die Aufkleber, sobald die Platten montiert sind.



Dieses Symbol zeigt an, dass sich die installierende Person sich im Inneren des Produktes befinden sollte.



Dieses Symbol zeigt an, dass sich die installierende Person an der Außenseite des Produktes befinden sollte.



Die mit Strichlinien markierten Schritte beziehen sich nur auf Erweiterungen. Einige der Schritte sind für den Zusammenbau eines einzelnen Produkts nicht relevant. Beim Zusammenbau eines einzelnen oder eines erweiterten Produkts können einige Teile überflüssig sein.

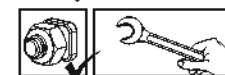

Diese 2 Symbole unten zeigen an, ob das Anziehen der Schrauben erforderlich ist oder nicht. Das vorübergehende Anziehen einiger Schrauben kann erforderlich sein, um ein Herausrutschen des Profils zu verhindern. Ziehen Sie nach Abschluss der Montage alle Schrauben fest.

CONSEJOS DE SEGURIDAD

- Es de suma importancia montar todas las partes de acuerdo con las instrucciones. No se salte ningún paso.
 - Recomendamos firmemente el uso de guantes de trabajo durante el montaje.
 - Use siempre zapatos y gafas de seguridad al trabajar con aluminio extruido.
 - Al usar una escalera plegable o herramientas eléctricas asegúrese de que sigue las instrucciones de seguridad de los fabricantes.
 - No toque los cables eléctricos aéreos con los perfiles de aluminio
 - No intente montar el invernadero en días de viento o días con humedad
 - Disponga todas las bolsas plásticas en lugar seguro - guárdelas fuera del alcance de niños.
 - Mantenga a los niños fuera del área de montaje.
 - No se apoye ni empuje el producto durante la construcción.
 - No coloque su producto en un área expuesta al viento excesivo
 - No intente montar este producto si usted está cansado, ha tomado drogas o alcohol o si usted es propenso a ataques de mareo.
 - Artículos calientes recientemente usados tales como parrillas, sopletes etc. no deben ser almacenados en el producto
 - Asegúrese de que no hay tuberías o cables ocultos en el suelo antes de andar a los cimientos.
 - Este producto fue diseñado para ser utilizado principalmente como un Cobertizo de jardín.
 - Para evitar que el agua se filtre por el suelo, el producto debe montarse sobre una superficie elevada del suelo.
 - **Asegúrese de anclar el producto directamente a una base sólida para aumentar su estabilidad y resistencia al viento, especialmente en áreas con condiciones climáticas severas. Asegúrese de que no haya obstáculos entre la zona de montaje y la posición final del producto.**
- El kit de andaje de Palram - Canopia puede adquirirse por separado.**

CUIDADOS & MANTENIMIENTO

- Para limpiar el producto, use un trapo suave y enjuague con agua limpia y fría
- NO use acetona, limpiadores abrasivos u otros detergentes especiales para limpiar los paneles transparentes.
- Limpie el producto una vez terminado el montaje.

ANTES DEL MONTAJE

- Seleccionar un lugar
 - Elija su sitio cuidadosamente antes del ensamblaje inicial.
 - El producto debe colocarse y fijarse en una superficie plana y nivelada.
 - Escoja una ubicación soleada y apartada de árboles que la cubran.
- El producto debe fijarse directamente a una superficie sólida
- Este montaje consta de varias partes y sería óptimo que lo realizasen dos personas. El proceso de montaje llevará alrededor de medio día.
- Extraiga todas las piezas de componentes de sus embalajes. Ordene las piezas y compruebe que están todas usando la lista de contenidos.
- Las piezas deberían colocarse cerca y tenerlas a mano. Ponga las piezas pequeñas (p. ej. tornillos) en un bol para no perderlas.
- Por favor, tenga en cuenta que este producto incluye perfiles con múltiples superficies. Como resultado, algunos de los agujeros de los perfiles no se utilizan durante el montaje.
- Por favor, revise todas las instrucciones antes de empezar. Siga los pasos del montaje en el orden exacto.
- Consulte las limitaciones, requisitos, permisos y a las autoridades locales para la construcción de este cobertizo de jardín.
- Por favor asegúrese de que tiene suficiente espacio lateral para la inserción de los paneles del techo durante el proceso de montaje

¡IMPORTANTE!

- Conecte firmemente el producto a una superficie nivelada inmediatamente después de terminar el montaje.
- Andar este producto al suelo es esencial para su estabilidad y rigidez. Es necesario completar esta fase para que su garantía sea válida.
- Durante el montaje, ponga algo suave por debajo de las piezas, para evitar que se rayen o estropeen.
- Recomendamos comprobar las restricciones o convenios para la construcción de este producto en su área. Además, aconsejamos comprobar si necesita presentar algún formulario o si se requiere algún permiso antes de construir el producto

DURANTE EL MONTAJE

Durante el montaje, se encontrará con diferentes iconos. Para obtener más información, consulte lo siguiente:



Puede utilizar spray lubricante de silicona para facilitar el deslizamiento de los paneles en los contornos. No ponga spray en los paneles.



Use un martillo de goma si hiciere falta.

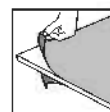

Asegúrese de quitar la película plástica que cubre ambos lados del panel.



Todos los paneles que tengan estampado LADO EXTERIOR (THIS SIDE OUT) deben mirar hacia fuera para ofrecer una protección UV completa. Quite la pegatina de plástico una vez los paneles se enganchen en su sitio



Este icono indica que el instalador debe estar dentro del producto.



Este icono indica que el instalador debe estar fuera del producto.

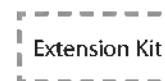

Los pasos marcados con líneas discontinuas se refieren únicamente a las extensiones.

Algunos de los pasos son innecesarios para el montaje de un solo producto.

Durante el montaje de un producto individual o de una extensión, pueden sobrar algunas piezas.



Los siguientes 2 iconos le indicarán si el ajuste de los tornillos es necesario o no.

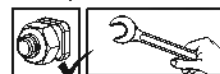

en algún paso puede ser necesario apretar de forma temporal algunos tornillos para evitar que se cargue un perfil

Apretar todos los tornillos una vez esté completado el montaje.

במהלך ההרכבה

במהלך ההרכבה, תפגוש אייקונים שונים למוצרים שונים, הבט מטה לטוד אינפורמציה:

ניתן להשתמש בספריי סיליקון בכדי לסייע לך להשחיל את הלוחות אל תוך הפרופילים. אין להתז ספריי סיליקון על הלוח.



במידת הצורך, השתמש בפטיש גומי.



הסר את ציפוי הפלסטיק משני צדדי הפנל לפני הרכבתו.

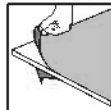

נא לשים לב שהלוחות מורכבים כאשר החלק המוגן נגד UV כלפי חוץ (מצוין עליו "THIS SIDE OUT") ולקלף בסיום את המדבקה כאשר הלוחות מונחים ונעולים במקומם.

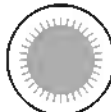

סמל זה מצוין שעל המרכיב להיות בתוך המוצר.



סמל זה מצוין שעל המרכיב להיות מחוץ למוצר.



השליבים המסומנים בקו מקווקו מתייחסים אל ההארכה כלבד. ניתן להתקין עד שלושה מוצרים מחוברים יחד. חלק מהשליבים אינם רלוונטיים להרכבת גגון אחד. בעת הרכבת מוצר בודד או מוצר הארכה, חלקים מסוימים עשויים להיות עודפים.



2 סמלים אלה מציינים האם נחוץ הידוק או לא. בחלק מהשליבים, הידוק זמני של הברגים עשוי להיות נחוץ בכדי למנוע את נפילתו של פרופיל. הדק את הברגים היטב בסיום ההרכבה.

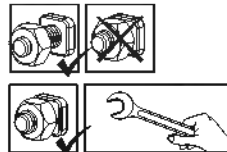

הצעת בטיחות

- יש להקפיד ולהרכיב את כל החלקים בהתאם להוראות. אין לדלג על שום שלב.
- אנו ממליצים מאוד להשתמש בכפפות עבודה במהלך ההרכבה.
- בעת השימוש באלומיניום משוחל יש לנעול תמיד נעלי עבודה ומשקפי מגן.
- בשימוש בסולם או במכשירים חשמליים, יש למלא אחר הוראות הבטיחות של היצרן.
- יש להמנע מנגוע של פרופילי האלומיניום עם כבל חשמל עוליים.
- אין לנסות להרכיב את המוצר בזמן רוחות או תנאי רטיבות. בכדי למנוע סכנת חנק, יש להרחיק את חומרי האריזה מהישג ידם של ילדים.
- יש להרחיק ילדים מאזור ההרכבה.
- אין להישען על או לדחוף את המוצר בעת ההרכבה.
- אין למקם את המוצר במקום החשוף לרוחות חזקות.
- אין לנסות להרכיב את המוצר במצב עייפות, שימוש בסמים, תרופות או אלכוהול, או אם יש נטייה לסחרחורת.
- אין לאחסן במוצר פריטים חמים כגון גריל שנעשה בו שימוש לאחרונה, מבערים וכד'.
יש לוודא כי אין צינורות או כבלים נסתרים בקרקע או הקיר לפני העיגון אל המשטח הקיים.
- מוצר זה תוכנן לשמש בעיקר כמחסן.
- כדי למנוע מים לחלחל דרך הרצפה, יש להתקין את המוצר על גבי משטח מוגבה מהקרקע.
- עליך לעגן את המוצר ישירות אל בסיס מוצק בכדי להגדיל את יציבות המוצר ועמידות לרוחות באזורים עם תנאי מזג אוויר קשים.**
- יש לוודא כי אין מכשולים בין אזור ההרכבה למיקום הסופי של המוצר. את ערכת העיגון של Palram - Canopia ניתן לרכוש בנפרד.**

טיפול ותחזוקה

- כדי לנקות את המוצר, יש להשתמש במטלית רכה ולשטוף במים נקיים קרים.
- אין להשתמש באצטון, חומרי ניקוי שוחקים וסבונים מיוחדים.
- יש לנקות את המוצר בסיום ההתקנה.

לפני ההרכבה

- בחירת מיקום ההרכבה:
 - בחר בתשומת לב את מיקום ההרכבה לפני תחילת ההרכבה.
 - יש לבחור אזור שטוף-שמש, רחוק מהעצים.
 - על הקרקע להיות שטוחה ומפולסת לחלוטין ובעלת בסיס מוצק כגון: בטון, אספלט, דק מעץ וכו'.
- יש למקם את המוצר ולקבע אותו על משטח שטוח וישירות לבסיס מוצק.
- זהו מוצר מרובה חלקים, לשם הרכבתו יש צורך בשני אנשים. תכנן לפחות חצי יום לביצוע ההרכבה.
- יש למיין את החלקים ולבדוק כמויות אל מול רשימת התכולה.
- יש להניח את חלקי ההרכבה בקרבה למקום ההרכבה. שמור את החלקים הקטנים בקערה על מנת שלא יאבדו.
- יתכן שבמוצר זה ישנם פרופילים שיש להם שימושים שונים, לכן יתכנו חורים שאין בהם צורך.
- אנא עיין בהוראות המלאות לפני שתתחיל. בצע את שלבי ההרכבה בסדר המדויק.
- אנא בדוק מול הרשויות אם יש צורך בהיתרים כלשהם טרם הרכבת המוצר.
- אנא וודא שקיים מספיק מרווח בצדדים להכנסת לוחות הגג במהלך ההרכבה.

חשוב!

- עיגון המוצר לקרקע חיוני ליציבות ועמידותו. חוקף האחירות תלוי בהשלמת שלב זה.
- מיד לאחר השלמת ההרכבה, יש לעגן מיד את המוצר היטב כשהקרקע במצב מפולס. חובה להשלים שלב זה בכדי שהאחריות תהיה בתוקף.
- בעת ההרכבה, השתמש במשטח רך מתחת לחלקים בכדי למנוע שריטות ונזק.
- אנו ממליצים לבדוק האם יש מגבלות חוקיות להקמת מבנה זה באזורכם.
- בנוסף, אנחנו מציעים שתבדקו האם אתם חייבים להגיש תפסים כלשהם, האם יש צורך בהיתר לפני שאתם מתחילים בבנייתו של המוצר.

SÄKERHETSÅD

- Följ monteringsanvisningarna i den ordning som anvisas i instruktionerna, hoppa inte över något steg
- Vi rekommenderar att handskar, skor och skyddsglasögon alltid används då man arbetar med metallprofiler
- Vid användning av stege, redskap och bormaskin, följ tillverkarens säkerhetsråd
- Var noga med att inte komma i kontakt med elkablar då metallprofiler hanteras.
- Undvik att montera produkten i dåligt, blåsigt väder eller regn.
- Ta väl hand om all plastpåsar och se till att de är utom räckhåll för barn.
- Låt inte barn vistas på monteringsplatsen och håll omgivningen snygg
- Luta eller tryck inte på produkten under montering
- Välj omsorgsfullt platsen för produkten så att det inte påfrestras av kraftig vind eller extra snö.
- Försök inte att sätta ihop denna produkt om du är trött, har tagit droger, druckit alkohol eller om du brukar ha yrselattacker.
- Heta föremål som en nyligen använd grill, blåslampa eller dylikt får inte förvaras i produkten.
- Se till att det inte finns några gömda rör eller kablar i grunden innan du förankrar i grunden.
- Denna produkt har utformats för att huvudsakligen användas som en Trädgårdsskjul.
- För att förhindra att vatten sipprar genom golvet måste produkten monteras på en upphöjd yta från marken
- **Se till att förankra produkten direkt på en solid grund för att öka produktens stabilitet och vindmotstånd, speciellt i områden med svåra väderförhållanden. Säkerställ att det inte finns några hinder mellan förankringsområdet och den slutliga positionen för produkten. Palram - Canopia förankringsset finns tillgängligt för köp separat.**

RENGÖRINGSINSTRUKTIONER

- När din produkt behöver rengöras, använd en mjuk trasa och skölj med kallt rent vatten.
- Använd inte aceton, rengöringsmedel innehållande slipmedel, eller andra specialmedel för att rengöra panelerna.
- Gör ren produkten när ihopsättningen är klar.

FÖRE MONTERING

- Välj en webbplats:
 - Välj plats noggrant innan du påbörjar monteringen.
 - Välj en solig plats utan överhängande träd.
 - Produkt måste placeras på en fast och plant underlag.
- Produkten måste förankras direkt till en solid grund.
- Detta är en flerdagad montering som bäst uppnås av två personer. Tillåt minst en halv dag för montering
- Sortera delarna och kontrollera mot komponentlistan.
- Delarna bör läggas ut nära dig. Ha alla små delar (skruvar etc.) i en skål så att de inte försvinner.
- Observera att flersidiga profiler används i denna dörrmarkis. Som ett resultat används vissa hål i profilerna inte under montering.
- Läs igenom hela instruktionerna innan du börjar. Utför monteringsstegen i exakt ordning.
- Kontakta dina lokala myndigheter hurvida tillstånd krävs innan byggnation av produkten.
- Se till att du har tillräckligt med sidoutrymme för att sätta takpanelerna under monteringsprocessen

VIKTIG!

- Anslut produkten ordentligt till en plan yta omedelbart efter avslutad montering
- Att förankra denna produkt vid mark är avgörande för dess stabilitet och styvhet. Det krävs att du slutför detta steg för att garantin ska vara giltig.
- Det är rekommenderat att använda en kartong eller annat mjukt material under det nedsänkta hömet för att undvika repor och avskrapning av färg.
- Vi rekommenderar att du kontrollerar begränsningarna och begränsningarna för konstruktionen av denna produkt i ditt område. Dessutom rekommenderar vi att du kontrollerar om du behöver fylla i formulär eller ansöka om tillstånd innan du bygger produkten.

UNDER MONTERING

Under montering kommer du att stöta på olika ikoner för olika produkter. Se nedan för mer information:



Du kan använda siliconsprej för panelerna lättare skall glida in i profilerna. Spreja inte på panelerna.



Använd en gummiklubba om nödvändigt.

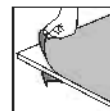

Se till att du tar bort täckande plastfilm från båda sidor om panelen.

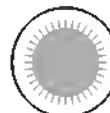

Alla paneler stämpade med orden "THIS SIDE OUT" måste vändas utåt för att skapa ett fullt UV-skydd. Avlägsna klistermärken allteftersom panelerna är låsta på plats.



Denna ikon anger att installatören bör befinna sig inne i produkten.



Denna ikon anger att installatören bör befinna sig utanför produkten



Steg markerade med streckade konturer gäller endast tillägg. Några av stegen är irrelevanta för montering av en enda produkt. Vid montering av en produkt eller en utökning av produkten kan en del bli ett överskott av delar

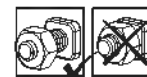

Dessa två ikoner anger om du behöver dra åt skruv eller inte.



I vissa steg kan emellertid temporär åtdragning av ett par skruvar vara nödvändigt för att förhindra att en profil faller ner. Drag åt alla skruvar avslutet av monteringen

SIKKERHETSÅD

- Utfør monteringen i henhold til disse anvisningene
- Bruk vernehansker.
- Bruk sko og vernebriller ved arbeid med aluminiumsprofiler.
- Følg produsentens sikkerhetsanvisninger for verktøy og annet utstyr.
- Pass på at aluminiumsprofilene ikke kommer i kontakt med strømkabler eller ledninger.
- Ikke forsøk å montere produktet når det blåser eller regner
- Emballasjen skal avhendes i henhold til gjeldende regler. Oppbevar plastposer utilgjengelig for barn – kvelningsfare
- Hold barn på trygg avstand fra arbeidsområdet
- Ikke trykk eller vipp på produktet under monteringen.
- Ikke plasser produktet slik at det utsettes for sterk vind.
- Forsøk aldri å montere produktet hvis du er trøtt eller påvirket av narkotika, legemidler eller alkohol.
- Varmt gjenstander som for eksempel brukte griller, blowtorches etc. må ikke lagres inne i produktet.
- Før du forankrer produktet i fundamentet, sørg for at det ikke er skjulte rør eller kabler der.
- Dette produktet ble laget for å brukes i hovedsak som Hageskur
- For å forhindre at vann siver gjennom gulvet, må produktet monteres på en hevet overflate fra bakken.
- **For å øke stabiliteten og vindmotstanden til produktet, må du forankre det direkte på et solid fundament, spesielt i de områdene der værforholdene er alvorlige. Forsikre deg om at det ikke er noen hindringer mellom forankringsområdet og produktets endelige posisjon. Palram - Canopia forankringssett kan kjøpes separat.**

VEDLIKEHOLD OG RENGJØRING

- Når produktet ditt må rengjøres, bruk en myk klut og skyll med kaldt rent vann.
- Bruk ikke acetone, slipende rengjøringsmidler eller andre kjemikalier på deggjennomslittige delene
- Rengjør produktet når monteringen er ferdig.

FØR MONTERING

- Velge et sted
 - Velg grunnlaget med omhu før du monterer
 - Velg en solrik beliggenhet uten overhengende trær.
 - Produkt må plasseres og festes på et flatt underlag.
- Produktet må festes direkte på en solid overflate.
- Denne flerdelte monteringen oppnås best av to personer. Beregn minst en halv dag for monteringsprosessen.
- Sorter delene og sjekk dem opp mot delelisten.
- Delene bør legges ut slik at du lett kan nå dem. Hold alle små deler (skruer osv) i en bolle slik at de ikke forsvinner
- Legg merke til at flersidige profiler er brukt i dette produktet. Dette betyr at enkelte av hullene profilene ikke blir brukt under monteringen.
- Les gjennom hele instruksjonene før du starter. Utfør monteringsstrinnene i nøyaktig rekkefølge.
- Kontakt lokale myndigheter for å se om du trenger byggetillatelse for å sette opp dette produkt.
- Forsikre deg om at du har tilstrekkelig sideplass for å sette inn takpanelene under monteringsprosessen.

VIKTIG!

- Etter fullført montering må produktet forankres umiddelbart på et flatt underlag
- Forankring av dette produktet til gulvet er avgjørende for dets stabilitet og styrke. Dette trinnet er også nødvendig på grunn av garantens gyldighet.
- Det anbefales å bruke kartong eller et annet mykt materiale under det senkede hjørnet for å unngå riper og malingsskader.
- Vi anbefaler at du sjekker restriksjoner og begrensninger for konstruksjon av dette produktet i ditt område.
- I tillegg anbefaler vi at du sjekker om du må fylle ut skjemaer eller søke om tillatelse før du bygger produktet.

UNDER FORSAMLINGEN

Under montering vil du møte på forskjellige ikoner for forskjellige produkter. Vennligst se nedenfor for mer informasjon:



Du kan bruke silikonspray for å hjelpe med at panelene sklir inn i profilene. Ikke spray paneler.



Bruk gummihammer hvis nødvendig.

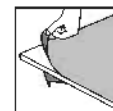

Må du sørge for å fjerne dekkende plastfilm fra begge sider av panelet.



Alle panelene med de stemplede ordene "THIS SIDE OUT" må vendes ut for å danne fullstendig UV-beskyttelse. Fjern plastfilmen når panelene er festet på plass



Dette symbolet indikerer at montøren skal befinne seg på utsiden.



Dette symbolet indikerer at montøren skal befinne seg på innsiden.

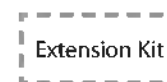

Trinn markert med stiplede ytterlinjer viser kun til utvidelser. Noen av trinnene er uten betydning for montering av et enkelt produkt. Når du setter sammen et enkelt eller et utvidet produkt, kan noen deler være til overs.

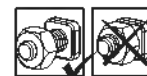

Disse to ikonene indikerer om det er nødvendig å stramme skruene. Til midlertid kan være nødvendig å midlertidig stramme enkelte skruer for noen av trinnene for å hindre av profilen faller.



Stram alle skruer når du er ferdig med monteringen.

TURVALLISUUSOHJEET

- Ensimmäisen tärkeää on noudattaa asennusohjeen järjestystä ja ohjeita – älä jätä mitään tekemättä
- Suosittelemme suojakäsineiden käyttöä asennustyössä
- Käytä aina tukevia kenkiä ja suojalaseja työskennellessäsi metallituotteiden kanssa.
- Jos käytät tikkaita, apuvälineitä, akkuporakonetta - varmista aina myös työkalu valmistajan käyttöohjeet.
- Älä kosketa sähköjohtoja tai lähteitä metallisten esineiden kanssa.
- Älä yritä pystyttää / asentaa kasvihuonetta tuulisella, sateisella tai huonolla säällä
- Hävitä huolellisesti kaikki muoviset pakkaustuotteet ja varmista ettei ne pääse pienten lasten lähetyville
- Pidä lapset loitolla työskentely alueelta ja pidä myös alue aina siistinä
- Älä työnnä tai nojaa kasvihuoneen rakenteisiin asennusvaiheen aikana.
- Valitse huolella kasvihuoneen sijainti, siten ettei se ole alttiina kovalle tuulelle tai ylimääräisille lumikuormille.
- Älä yritä asentaa tätä kasvihuonetta puolikuntoisena, väsyneenä, päihtyneenä tai lääkityksen vaikutuksen alaisena.
- Kuumat tuotteet kuten grillit, polttotyökälyt, terassilämmittimet tulee säilöä muulla kuin kasvihuoneessa.
- Varmista ennen tuotteen ankkuroimista perustukseen, ettei siellä ole piilossa olevia putkia tai kaapeleita
- Tämä tuote on suunniteltu käytettäväksi pääosin as Puutarhavajat.
- Veden lattiaa kautta vuotamisen estämiseksi tuote on sijoitettava irti maasta korotetulle pinnalle.
- **Tuotteen vakauden ja tuulenpitävyyden lisäämiseksi sinun on ankkuroitava se suoraan tukevalle alustalle, erityisesti alueilla, joilla sääolosuhteet ovat ankarat. Varmista, että tuotteen kokoamisalueen ja sen lopullisen sijoituspaikan välillä ei ole esteitä. Palram - Canopia ankkurointisarja voidaan ostaa erikseen.**

PUHDISTUSOHJEET

- Kun tuotteesi on puhdistettava, käytä pehmeää liinaa ja huuhtelee kylmällä puhtaalla vedellä
- Älä käytä paneelin puhdistukseen asetonia, hankaavia tai muita erikoispuhdistusaineita.
- Puhdista tuote kokoamisen jälkeen.

ENNEN KOKOAMISTA

- Sijainnin valinta:
 - Valitse paikka huolellisesti ennen kokoamista
 - Valitse aurinkoinen paikka, jonka yllä ei roiku oksia.
 - Seinä pinnan on oltava täysin tasainen ja suora, ja perustan oltava kiinteä.
- Tuote on kiinnitettävä suoraan kiinteälle pinnalle.
- Kokoaminen on moniosainen työ, jonka suorittaa parhaiten kaksi henkilöä. Varaa ainakin puoli päivää kokoamisprosessille
- Lajittelu osat ja tarkasta ohjeen mukainen sisältö.
- Osat on sijoitettava käden ulottuville. Pidä kaikki pienet osat (ruuvit yms.) astiassa, jotta ne eivät pääse hukkuumaan
- Huomaa, että tässä tuotteessa käytetään monivivuisia tukirankoja, joten kaikkia niissä olevia reikiä ei käytetä kokoamiseen.
- Lue koko käyttöohje ennen aloittamista. Suorita kokoamisvaiheet tarkassa.
- järjestyksessä. Kysy tarvittaessa paikallisten viranomaisten lupaa katoksen pystyttämiseen.
- Varmista, että sinulla on riittävästi sivutillaa kattopaneelin sijoittamiseen kokoonpanon aikana

TÄRKEÄ!

- Asennuksen päätyttyä tuote on ankkuroitava välittömästi tasaiselle pinnalle
- Tämän tuotteen ankkurointi että lattiaan on välttämätöntä sen vakauden ja lujouden kannalta. Tämä vaihe on tarpeen myös takuun vuoksi
- Käytä pehmeää alustaa estääksesi naarmut ja vahingot
- Suosittelemme, että tutustut tämän tuotteen rakentamiseen liittyviin rajoituksiin tai sopimuksiin alueellasi.
- Lisäksi suosittelemme, että tarkistat, onko sinun toimitettava lomakkeita tai hankittava lupa ennen tuotteen rakentamista.

ASENNUKSEN AIKANA

Kokoamisen aikana näet erilaisia kuvakkeita eri tuotteita varten.

Katso lisätietoja alta:



Voit käyttää silikonisprayta apuna paneelien liuuttamisessa profiileihin. Älä käytä sprayta paneeleihin.



Käytä tarvittaessa kumivasaraa.

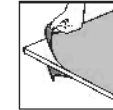

Muista poistaa peittävä muovikalvo paneelin molemmilta puolilta.

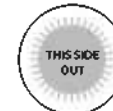

Kaikki paneelit, joihin on leimattu sanat "THIS SIDE OUT" ("tämä puoli ulospäin") on asetettava ulospäin, jotta syntyy täysi UV-suojaus. Poista muovitarat, kun paneelit on lukittu paikoilleen.



Tämä kuvake osoittaa, että asentaja pitäisi olla tuotteen ulkopuolella.



Tämä kuvake osoittaa että asentajan pitäisi olla tuotteen sisällä.



Katkovivuoilla ympäröidyt vaiheet ovat vain laajennuksia varten. Jotkin osat ovat merkityksettä yksittäisen tuotteen kokoamisessa. Kootessasi yksittäistä tai laajennettua tuotetta, jotkin osat voivat olla tarpeettomia.



Nämä 2 kuvakkeet ilmaisevat tarvitaanko kiristää ruuveja vai ei. Joissakin vaiheissa muutaman ruuvien väliaikainen kiristys voi olla kuitenkin tarpeen tukirangan kaatumisen estämiseksi.



Kiristä kaikki ruuvit asennuksen loppuun.

SIKKERHEDSRÅD

- Det er meget vigtigt, at alle dele samles i henhold til anvisningerne. Spring ikke noget trin over.
- Vi anbefaler stærkt, at der anvendes arbejdshandsker under samlingen.
- Vær altid iført sko og anvend sikkerhedsbriller, når der arbejdes med ekstruderet aluminium.
- Hvis der bruges en trappestige eller elektrisk værktøj, skal producentens sikkerhedsanvisninger følges.
- Berør ikke luftledninger med aluminiumsprofilerne.
- Forsøg ikke at samle produktet, når det blæser eller er vådt i vejret.
- Bortskaf alle plastikposer på sikker måde. Hold dem udenfor små børns rækkevidde.
- Hold børn væk fra stedet, hvor samlingen foregår.
- Læn dig ikke mod produktet og skub ikke til det under monteringen.
- Anbring ikke produktet på et sted med kraftig vind.
- Forsøg ikke at samle produktet, hvis du er træt, er under indflydelse af narkotika, medicin eller alkohol, eller hvis du har tendens til svimmelhed.
- Varme ting såsom netop brugte griller, blæselamper osv må ikke opbevares i produktet.
- For du forankrer produktet i fundamentet, skal du sikre dig, at der ikke er skjulte rør eller kabler der.
- Dette produkt blev primært designet til at blive brugt som Haveskure.
- For at forhindre vand i at sive gennem gulvet, skal produktet monteres på en hævet overflade fra jorden.
- **For at øge produktets stabilitet og vindmodstand skal du forankre det direkte på et solidt fundament, især i de områder, hvor vejrforholdene er hårde. Sørg for, at der ikke er nogen forhindringer mellem monteringsområdet og produktets slutposition. Palram - Canopia Anchoring kit kan købes separat.**

RENGØRINGSVEJLEDNING

- Når dit produkt skal rengøres, skal du bruge en blød klud og skylle med koldt rent vand.
- Anvend ikke acetone, slibende rengøringsmidler, eller andre specialrengøringsmidler til at rengøre panelerne.
- Rengør produktet, når monteringen er udført.

FØR MONTERING

- Valg af sted:
 - Vælg stedet omhyggeligt inden du påbegynder samlingen
 - Vælg et solrigt sted uden overhængende træer.
 - Produkt skal placeres og opføres på en plan flade.
- Produktet skal fastgøres direkte til en fast overflade.
- Dette er et samlesæt med mange dele som lettest samles ved hjælp af to personer. Afsæt mindst en halv dag til at samle drivhuset.
- Tag alle dele ud af indpakningen. Sorter delene og tjek dem mod indholdslisten
- Placer delene, så du let kan nå dem. Opbevar alle små dele (skruer etc.) i en skål, så de ikke bliver væk.
- Vær opmærksom på, at der anvendes flersidede profiler i dette produkt. Derfor anvendes nogle huller i profilerne ikke i forbindelse med samlingen af produktet.
- Gennemgå hele vejledningen, før du går i gang. Udfør samlingen i den præcist angivne rækkefølge
- Henvend dig venligst til de lokale myndigheder hvis en tilladelse er påkrævet inden produktet konstrueres.
- Sørg for, at du har tilstrækkelig sideplads til at placere tagpanelerne under monterning.

VIGTIG!

- Efter færdiggørelse af montagen skal produktet forankres straks på en plan overflade.
- Forankring af dette produkt til gulvet er afgørende for dets stabilitet og styrke. Dette trin er også nødvendigt på grund af garantiens gyldighed
- For at undgå ridser eller skader, anvend en et blødt underlag under delene under monterning
- Vi anbefaler at kontrollere for begrænsninger eller regler for at bygge dette produkt i dit område.
- Derudover råder vi til at kontrollere, om du har brug for at indsende nogen formularer, eller om der kræves tilladelse, før du bygger produktet.

UNDER MONTERINGEN

Under monterning vil du støde på forskellige ikoner for forskellige produkter. Se venligst nedenfor for mere information:



Du kan anvende silikone-smøremiddel som hjælp til at få panelerne ind i profilerne. Spray ikke på pladerne.



Brug en gummihammer om nødvendigt

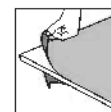

Skal du sørge for at fjerne dækplastfilm fra begge sider af panelet.

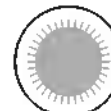

Alle paneler med de stempede ord "THIS SIDE OUT" skal vende udad for at skabe fuld UV beskyttelse. Fjern plastklister, når panelerne er låst på plads.



Dette ikon indikerer, at installatøren skal befinde sig inde i for produktet.



Dette ikon indikerer, at installatøren skal befinde sig uden for produktet.

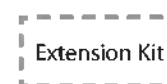

Trin markeret med stiplede konturer refererer kun til udvidelser. Nogle af trinene er irrelevante for monteringen af et enkelt produkt. Ved monteringen af et enkelt eller udvidet produkt kan nogle dele blive tilovers.

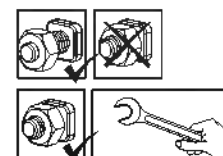

Disse 2 ikoner indikerer, om skruerne skal strammes eller ej. Midlertidig tilspænding af et par skruer kan være nødvendig for at forhindre, at en profil glider. Stram alle skruer når du er færdig med monteringen.

VEILIGHEIDSADVIES

- Het is uiterst belangrijk alle onderdelen volgens de richtlijnen te monteren. Sla geen enkele stap over.
- Het is ten zeerste aanbevolen om werkhandschoenen te dragen tijdens de montage.
- Draag altijd schoenen en een veiligheidsbril als u met geëxtrudeerd aluminium werkt.
- Als u een ladder of electrisch gereedschap gebruikt, wees zeker dat u het veiligheidsadvies van de fabrikant volgt.
- Raak de bovengrondse elektriciteitskabels niet aan met de aluminium profielen.
- Probeer de product niet te monteren in winderige of natte omstandigheden.
- Verwijder alle plastic veiligheidszakken en houd ze buiten bereik van kleine kinderen.
- Houd kinderen uit het montagegebied.
- Leun niet of druk niet aan de product gedurende de montage.
- Plaats uw product niet in een gebied met overmatige wind.
- Probeer de product niet te monteren indien u moe bent, drugs of alcohol gebruikt heeft of als u lijdt aan aanvallen van duizeligheid.
- Hete voorwerpen zoals recent gebruikte grills, branders, enz. mogen niet in de product opgeslagen worden.
- Zorg ervoor dat er geen verborgen leidingen of kabels zijn voordat u het product aan de fundering verankert.
- Dit product werd ontworpen om hoofdzakelijk te worden gebruikt als Tuinhuisjes.
- Om te voorkomen dat er water door de vloer sijpelt, moet het product vanaf de grond op een verhoogd oppervlak worden gemonteerd.
- **Om de stabiliteit en windweerstand van het product te vergroten, moet u het direct op een stevige ondergrond verankeren, vooral in die gebieden waar de weersomstandigheden zwaar zijn. Zorg ervoor dat er geen obstakels zijn tussen het montagegebied en de uiteindelijke positie van het product. De Palram - Canopia Anchoring kit is apart verkrijgbaar.**

SCHOONMAAK INSTRUCTIES

- Wanneer uw product gereinigd moet worden, gebruik dan een zachte doek en spoel af met koud, schoon water.
- Gebruik geen aceton, schurende detergents of andere speciale middelen voor het reinigen van de panelen.
- Maak het product schoon na assemblage.

VOÓR DE VERGADERING

- Selecteer een site:
 - Kies deze locatie zorgvuldig voordat u begint met de montage.
 - Kies een zonnige positie weg van overhangende bomen.
 - Het grondoppervlak moet perfect vlak en waterpas zijn en een stevige ondergrond hebben.
- Het product moet direct op een stevige ondergrond worden bevestigd.
- Dit is een multi-part montage en kan het beste worden gedaan door twee personen. Houd tenminste rekening met een halve dag voor het montageproces.
- Sorteer de onderdelen en controleer dit met de materiaallijst.
- Onderdelen moeten dicht bij de hand liggen. Bewaar alle kleine onderdelen (schroeven, enz.) in een kom zodat je ze niet verliest.
- Let wel dat er meerszijdige profielen worden gebruikt in product. Als gevolg kunnen er sommige gaten in de profielen zitten die niet worden gebruikt gedurende de montage.
- Lees de gehele instructies voordat u begint. Voer de montageschritten uit in de exacte volgorde.
- Raadpleeg uw plaatselijke autoriteiten of er bepaalde vergunningen vereist zijn voordat u het product gaat bouwen.
- Zorg ervoor dat u tijdens de montage voldoende zijruimte heeft om de dakpanelen te plaatsen.

BELANGRIJK!

- Na voltooiing van de montage moet het product direct op een vlakke ondergrond worden verankerd.
- Het verankeren van dit product aan de vloer is essentieel voor zijn stabiliteit en sterkte. Deze stap is ook nodig vanwege de geldigheid van de garantie.
- Gebruik een zachte ondergrond voor de onderdelen om krassen en beschadigingen te voorkomen.
- Wij raden u aan te controleren of er beperkingen of convenanten van toepassing zijn voor het bouwen van dit product in uw omgeving. Daarnaast adviseren wij om te controleren of u formulieren moet indienen of dat er een vergunning nodig is voordat u het product opbouwt.

TIJDENS DE ASSEMBLAGE

Tijdens de montage zult u verschillende iconen voor verschillende producten aantreffen. Kijk hieronder voor meer informatie:



U kunt siliconenspray gebruiken om de panelen gemakkelijker in de profielen te schuiven. Spray niet de panelen.



Gebruik een rubberen hamer indien nodig.

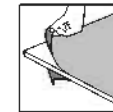

Moet u ervoor zorgen dat u de afdekfolie aan beide zijden van het paneel verwijdert.



Alle panelen met de gestempelde woorden "THIS SIDE OUT" moeten naar buiten wijzen om volledige UV-bescherming te creëren. Verwijder de plastic sticker nadat de panelen op hun plaats vast zijn gezet.



Dit icoontje geeft aan dat de installateur binnen het product moet zijn.



Dit icoontje geeft aan dat de installateur buiten het product moet zijn.



Stappen gemarkeerd met gestreepte omtrek verwijzen enkel naar uitbreidingen. Sommige van de stappen zijn irrelevant voor de montage van een enkel product. Bij het monteren van een enkel of een uitgebreid product, kunnen sommige onderdelen op overschot zijn.

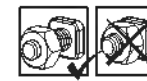

Deze 2 icoontjes geven aan of het vastdraaien van schroeven is vereist.

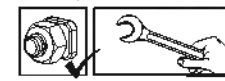

Tijdelijk vastzetten van een aantal schroeven is mogelijk nodig om te voorkomen dat een profiel naar buiten schuift. Maak het product schoon na assemblage.

CONSIGLIO DI SICUREZZA

- È di grande importanza montare le parti secondo le direttive. Non omettere alcuna fase.
- Raccomandiamo caldamente l'uso dei guanti di lavoro durante i lavori di montaggio.
- Indossare sempre scarpe ed occhiali di sicurezza nel maneggiare i profili di alluminio estruso
- Usando una scala a pioli o utensili elettrici da lavoro, assicurarsi di seguire le disposizioni di sicurezza fornite dal produttore
- Non toccare cavi elettrici con i profili d'alluminio
- Non tentare di montare la prodotto in condizioni atmosferiche ventose o umide.
- Eliminare in modo sicuro tutti i sacchetti di plastica – conservarli fuori della portata dei bambini.
- Tenere i bambini a distanza dall'area di montaggio.
- Non appoggiarsi o spingere la prodotto durante la sua costruzione
- Non posizionare la prodotto in un'area troppo esposta al vento.
- Non tentare di montare la prodotto in condizioni di stanchezza, dopo aver fatto uso di stupefacenti o alcolici o se si è soggetti ad avere capogiri.
- Oggetti roventi quali griglie o bruciatori per saldature usati di recente ecc., non devono essere introdotti nella prodotto.
- Assicurarsi che non ci siano tubi o cavi nascosti nel terreno prima di ancorare alla fondazione.
- Prodotto progettato per uso prevalente come Capanne da giardino.
- Per evitare che l'acqua penetri attraverso il pavimento, questo prodotto deve essere montato su una superficie elevata rispetto al livello del suolo
- **Assicuratevi di ancorare il prodotto direttamente a una base solida per aumentare la stabilità e la resistenza al vento, specialmente in aree con condizioni meteorologiche severe. Assicuratevi che non ci siano ostacoli tra l'area di montaggio e la posizione finale del prodotto. Il kit di ancoraggio Palram - Canopia può essere acquistato separatamente.**

ISTRUZIONI PER LA PULIZIA

- Per pulire il prodotto, utilizzare un panno morbido e risciacquare con acqua fredda pulita.
- Non utilizzare acetone, detergenti abrasivi o altri detergenti speciali per la pulizia dei pannelli.
- Pulisci il prodotto una volta che il montaggio è completo.

PRIMA DEL MONTAGGIO

- Seleziona un sito:
 - Scegliete con cura il vostro luogo di montaggio prima di assemblare.
 - Scegli una posizione soleggiata lontano dagli alberi sovrastanti.
 - Il prodotto deve essere posizionato e fissato su una superficie piana.
- Il prodotto deve essere fissato direttamente su una superficie solida.
- Questo è un montaggio multi-parte che può essere eseguito meglio da due persone. Bisogna utilizzare almeno una mezza giornata per l'intero processo di montaggio.
- Estrai tutte le parti dei componenti presenti nei pacchetti. Ordina le parti e controllale tramite l'elenco che mostra tutte le parti. Le parti devono essere a portata di mano.
- Metti tutte le parti piccole (viti, ecc) in una ciotola in modo che non si perdano.
- Considera che in questa prodotto vengono utilizzati dei profili multi-lato. Per questo motivo alcuni fori nei profili non vengono utilizzati durante il montaggio.
- Leggi tutte le istruzioni prima di iniziare. Esegui le fasi di montaggio nell'ordine esatto
- Si prega di consultare le vostre autorità locali in caso siano richiesti permessi prima di costruire il prodotto.
- Assicurarsi di disporre di uno spazio laterale sufficiente per l'inserimento dei pannelli del tetto durante il processo di montaggio.

IMPORTANTE!

- Collega saldamente la Prodotto ad una posizione immediatamente dopo il completamento del montaggio.
- Il fissaggio di questo prodotto a terra è essenziale per ottenere stabilità e rigidità. Affinché la garanzia sia valida è necessario completare questo passaggio.
- Durante il montaggio utilizzare una superficie morbida sotto le parti per evitare graffi e danni.
- Si consiglia di verificare se ci sono restrizioni o autorizzazioni per la costruzione di questo prodotto nella vostra zona. Inoltre, si consiglia di controllare se è necessario presentare dei moduli o se è necessario un permesso prima di costruire il prodotto.

DURANTE IL MONTAGGIO

Durante il montaggio, troverete diverse icone corrispondenti a diversi prodotti. Per ulteriori informazioni, si prega di fare riferimento a quanto segue:



Puoi utilizzare lo spray lubrificante al Silicone per aiutare i pannelli a scorrere nei profili. Non spruzzare sui pannelli.



Usa un martello di gomma, se necessario.

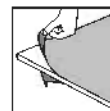

Assicurarsi di rimuovere la pellicola di plastica di copertura da entrambi i lati del pannello.



Tutti i pannelli con le parole stampate "THIS SIDE OUT" devono essere rivolti verso l'esterno per creare una protezione UV completa. Rimuovere l'adesivo di plastica mentre i pannelli sono bloccati in posizione.



Questa icona indica che l'installatore deve essere all'interno del prodotto.



Questa icona indica che l'installatore deve essere all'esterno del prodotto.

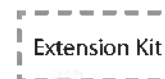

I passi segnati con linee tratteggiate si riferiscono solo alle estensioni. Alcuni passi non sono necessari per l'assemblaggio di un singolo prodotto. Durante l'assemblaggio di un singolo prodotto o di un'estensione, alcune parti possono essere rimanenti.

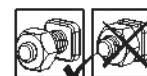

Queste 2 icone indicano se è necessario o meno serrare le viti. Può essere necessario stringere temporaneamente alcune viti per evitare che un profilo si sposti fuori posto. Stringi tutte le viti al termine del montaggio





IMPORTANT ASSEMBLY STEPS

When encountering this information icon during assembly, please refer the relevant assembly step for important additional comments.

- Step 1:** If you've purchased a **WPC Floor Kit**, do not assemble profile **#8851!**
- Step 8:** If you're installing a **WPC Floor Kit**, measure and cut floor board **#8912**.
- Step 19:** Matte side of all product's panels should be facing out!
Use mild soap if needed to ease sliding of profiles & panels.
- Step 22:** It is recommended to insert screws **#8192** as preparation for mounting shelves.
If you've purchased a **Utility Shed Shelf Kit**, mount a maximum of 2 shelves per post. If you have purchased the **Yukon Shed + Extension** - go to the next step.
- Step 23:** It is recommended to insert screws **#8192** as preparation for mounting shelves.
If you've purchased a **Utility Shed Shelf Kit**, mount a maximum of 2 shelves per post.
- Step 32:** Before inserting the screws, make sure the internal metal profiles are not protruding.
- Step 33:** Before inserting the screws, make sure the internal metal profiles are not protruding and are well connected with one another inside the aluminum profiles.
- Step 36:** The sticker must be placed on a clean and dry surface.
- Step 45:** Slow down and be careful when sliding the panels in.
- Step 49:** Make sure the distance between the wall's aluminum profiles and gutter is identical prior to tightening the screws on the inside.
- Step 66:** Make sure the shed is leveled prior to anchoring it to the surface of your choosing. Use suitable screws and plugs (not supplied).



PRINCIPALES ÉTAPES D'ASSEMBLAGE

Lorsque vous rencontrez cette icône d'information pendant l'assemblage, veuillez vous référer à l'étape d'assemblage correspondante pour d'autres commentaires importants.

- Étape 1:** Si vous achetez un **kit de sol WPC**, n'assemblez pas le profilé **#8851!**
- Étape 8:** Si vous installez un **kit de sol WPC**, mesurez et coupez panneau de sol numéro **# 8912**.
- Étape 19:** Le côté mat de tous les panneaux du produit devrait être tourné vers l'extérieur !
Utilisez un savon doux si nécessaire pour faciliter le glissement des profilés et des panneaux.
- Étape 22:** Il est recommandé d'insérer les vis **#8192** comme préparation pour les tablettes de montage. Si vous avez acheté un **kit d'étagère**, montez un maximum de 2 étagères par poste. Si vous avez acheté le **Yukon + Extension** - passez à l'étape suivante.
- Étape 23:** Il est recommandé d'insérer des vis **#8192** comme préparation pour le montage des étagères.
Si vous avez acheté un **kit d'étagère**, montez un maximum de 2 étagères par poteau.
- Étape 32:** Avant d'insérer les vis, assurez-vous que les profilés métalliques internes ne dépassent pas.
- Étape 33:** Avant d'insérer les vis, assurez-vous que les profilés métalliques internes ne dépassent pas et sont bien connectés les uns aux autres à l'intérieur des profilés d'aluminium.
- Étape 36:** L'autocollant doit être placé sur une surface propre et sèche.
- Étape 45:** Ralentissez et faites attention lorsque vous y glissez les panneaux.
- Étape 49:** Assurez-vous que la distance entre les profilés d'aluminium du mur et la gouttière est identique avant de serrer les vis à l'intérieur.
- Étape 66:** Assurez-vous que l'abri de jardin est nivelé avant de l'ancrer sur la zone de votre choix.



WICHTIGE MONTAGESCHRITTE

Wenn Sie bei der Montage auf dieses Informationssymbol stoßen, finden Sie im jeweiligen Montageschritt wichtige Zusatzhinweise.

- Schritt 1:** Wenn Sie ein **WPC-Bodenkit** gekauft haben, montieren Sie das Profil mir der Nr. **8851** nicht!
- Schritt 8:** Wenn Sie einen **WPC-Bodenkit** installieren, messen und schneiden Sie die Bodenplatte Nr. **8912**.
- Schritt 19:** Die matte Seite aller Produktplatten sollte nach immer außen verlegt werden! Verwenden Sie milde Seife, wenn nötig, um das Gleiten von Profilen und Paneelen zu erleichtern.
- Schritt 22:** Es wird empfohlen, die Schrauben Nr. **8192** als Vorbereitung für die Montage von Regalen einzusetzen. Falls Sie ein **Regal-Kit** gekauft haben, montieren Sie maximal 2 Regalböden pro Pfosten. Falls Sie die **Yukon + Extension** gekauft haben, fahren Sie mit dem nächsten Schritt fort.
- Schritt 23:** Es wird empfohlen, die Schrauben Nr. **8192** als Vorbereitung für die Montage von Regalen einzusetzen.
Falls Sie ein **Regal-Kit** gekauft haben, montieren Sie maximal 2 Regalböden pro Pfosten.
- Schritt 32:** Vor dem Einsetzen der Schrauben sicherstellen, dass die inneren Metallprofile nicht vorstehen.
- Schritt 33:** Vor dem Einsetzen der Schrauben sicherstellen, dass die inneren Metallprofile nicht vorstehen und in den Aluminiumprofilen gut miteinander verbunden sind.
- Schritt 36:** Der Aufkleber muss auf eine saubere und trockene Oberfläche gelegt werden.
- Schritt 45:** Seien Sie langsam und vorsichtig beim Einschieben der Paneele.
- Schritt 49:** Vergewissern Sie sich, dass der Abstand zwischen den Aluminiumprofilen der Wand und der Rinne identisch ist, bevor Sie die Schrauben an der Innenseite anziehen.
- Schritt 66:** Vergewissern Sie sich, dass der gesamte Schuppen nivelliert ist, bevor Sie ihn am Grund Ihrer Wahl verankern. Verwenden Sie geeignete Schrauben und Dübel (nicht im Lieferumfang enthalten).



PASOS DE MONTAJE IMPORTANTES

Al encontrar este icono de información durante el montaje, consulte el paso de montaje correspondiente para obtener importantes comentarios adicionales.

- Paso 1:** Si ha comprado un **WPC Kit de Piso**, ¡no ensamble el perfil #8851!
- Paso 8:** Si estas instalando **WPC Kit de Piso**, mide y corta la tabla de piso #8912!
- Paso 19:** ¡El lado mate de todos los paneles del producto debe estar mirando hacia afuera!
- Paso 22:** Es recomendado insertar los tornillos #8192 como preparacion para las repisas de montar. Si ha comprado el **Juego de estantería**, un maximo de 2 por poste. Si ha comprado la extension **Yukon Shed + modulo de ampliación**, por favor proceda al paso siguiente.
- Paso 23:** Es recomendado insertar los tornillos #8192 como preparacion para las repisas de montar.
Si ha comprado el **Juego de estantería**, un maximo de 2 por poste.
- Paso 32:** Antes de insertar los tornillos, asegúrese de que los perfiles metálicos internos no sobresalgan
- Paso 33:** Antes de insertar los tornillos, asegúrese de que los perfiles metálicos internos no sobresalgan y estén bien conectados entre sí, dentro de los perfiles de aluminio.
- Paso 36:** La etiqueta debe ser colocada en una superficie limpia y seca.
- Paso 45:** Al deslizar los paneles hacia adentro, desacelere y tenga cuidado.
- Paso 49:** Asegúrese de que la distancia entre los perfiles de aluminio de la pared y la canaleta sea idéntica antes de apretar los tornillos en el interior.
- Paso 66:** Asegúrese de que el cobertizo esté nivelado antes de anclarlo a la superficie que elija. Use tornillos y tacos adecuados (no incluidos).



VIKTIGA MONTERINGSSTEG

När du ser denna ikon under montering, se relevant monteringssteg för viktiga ytterligare kommentarer.

- Steg 1:** Om du har köpt ett **WPC golv-kit**, montera inte profil #8851!
- Steg 8:** Om du installerar ett **WPC golv-kit**, mär och skär golvbräda #8912.
- Steg 19:** Den matta sidan av alla produkters paneler ska vändas utåt!
Använd mild tvål om det behövs för att lättare glida profiler och paneler.
- Steg 22:** Det rekommenderas att föra in skruvarna #8192 som förberedelse för montering av hyllor.
Om du har köpt ett **Verktygsskjul hyll-kit**, montera högst 2 hyllor per post. Om du har köpt **Yukon-skjulet + Extension** - gå till nästa steg.
- Steg 23:** Det rekommenderas att föra in skruvarna #8192 som förberedelse för montering av hyllor.
Om du har köpt ett **Verktygsskjul hyll-kit**, montera högst 2 hyllor per post.
- Steg 32:** Innan du sätter in skruvarna, se till att de inre metallprofilerna inte sticker ut.
- Steg 33:** Innan du sätter in skruvarna, se till att de inre metallprofilerna inte sticker ut och att de är väl anslutna till varandra inuti aluminiumprofilerna.
- Steg 36:** Klistermärket måste placeras på en ren och torr yta.
- Steg 45:** Sakta ner och var försiktig när du skjuter in panelerna.
- Steg 49:** Kontrollera att avståndet mellan väggens aluminiumprofiler och rännan är identiskt innan du spänner åt skruvarna på insidan.
- Steg 66:** Se till att skjulet är jämnt innan du förankrar det till ytan du valt.
Använd lämpliga skruvar och pluggar (medföljer ej).

שלבים חשובים בהרכבה



כאשר אתם רואים את הסמל הזה במהלך ההרכבה, אנא פנו אל שלב ההרכבה לקבלת הערות חשובות נוספות.

- שלב 1:** אם רכשת **ערכת רצפה WPC**, אל תרכיב את פרופיל #8851!
- שלב 8:** אם אתה מרכיב **ערכת רצפה WPC**, מדוד וחתוך את לוח הרצפה #8912!
- שלב 19:** הצד המט של כל לוחות המוצר צריך לפנות כלפי חוץ! השתמש בסבון עדין אם הדבר נדרש להכנסה קלה של הפרופילים והלוחות.
- שלב 22:** מומלץ להכניס את הברגים #8192 כהכנה להתקנת מדפים.
אם רכשת **ערכת מדף למחסן**, הרכב לכל היותר 2 מדפים על כל עמוד.
אם רכשת **סככת יוקון + הרחבה** - עבור לשלב הבא.
- שלב 23:** מומלץ להכניס את הברגים #8192 כהכנה להתקנת מדפים.
אם רכשת **ערכת מדף למחסן**, הרכב לכל היותר 2 מדפים על כל עמוד.
- שלב 32:** לפני הכנסת הברגים, וודא שפרופילי המתכת הפנימיים אינם בולטים.
- שלב 33:** לפני הכנסת הברגים, וודא שפרופילי המתכת הפנימיים אינם בולטים כלפי חוץ ושהם מחוברים היטב זה לזה בתוך פרופילי האלומיניום.
- שלב 36:** יש לשים את המדבקה על משטח נקי ויבש.
- שלב 45:** עבוד לאט ובזהירות בעת החלקת הלוחות פנימה.
- שלב 49:** וודא שהמרחק בין פרופילי האלומיניום של הקירות והמרב זהה לפני הידוק הברגים מבפנים.
- שלב 66:** וודא שהמחסן מיושר לפני עיגונו למשטח שבחרת.
השתמש בברגים וביתדות מתאימים (לא כלולים בערכה).



VIKTIGE MONTERINGSTRINN

Når du ser dette ikonet under montering, vennligst se relevant monteringstrinn for viktige tilleggskommentarer.

- Trinn 1:** Hvis du har kjøpt et gulvsett skal du ikke montere profil #8851!
- Trinn 8:** Hvis du monterer et gulvsett -boden skal du ikke kutte gulvplanke #8912.
- Trinn 19:** Den matte siden skal vende ut på alle paneler! Bruk mild såpe hvis nødvendig for å gjøre skyvingen av profiler og paneler lettere.
- Trinn 22:** Det anbefales å sette inn skruene #8192 som forberedelse til montering av hyllene.
Hvis du har kjøpt et hyllesett, bør du montere maks 2 hyller per stang.
Hvis du har kjøpt Yukon Shed + Extension - gå til neste trinn.
- Trinn 23:** Det anbefales å sette inn skruene #8192 som forberedelse til montering av hyllene.
Hvis du har kjøpt et hyllesett, bør du montere maks 2 hyller per stang.
- Trinn 32:** Før du setter inn skruene, må du sørge for at de indre metallprofilene ikke stikker ut.
- Trinn 33:** Før du setter inn skruene, må du sørge for at de indre metallprofilene ikke stikker ut og er godt festet til hverandre inne i aluminiumsprofilene.
- Trinn 36:** Klistremerket må plasseres på en ren og tørr overflate.
- Trinn 45:** Vær forsiktig når du skyver inn panelene.
- Trinn 49:** Pass på at avstanden mellom veggens aluminiumsprofiler og takrennen er like lang før du trekker til skruene på innsiden.
- Trinn 66:** Sørg for at boden står flatt før du forankrer den til underlaget.
Bruk egnede skruer og plugger (ikke inkludert).



TÄRKEÄT ASENNUSVAIHEET

Kun näet tämän tietokuvakkeen asennuksen aikana, katso tärkeät lisähuomautukset olennaisesta asennusvaiheesta.

- Vaihe 1:** Jos olet hankkinut WPC-lattiasarjan, älä kokoa profiilia #8851!
- Vaihe 8:** Jos olet asentamassa WPC-lattiasarjaa, mittaa ja leikkaa lattialevy # 8912.
- Vaihe 19:** Kaikkien tuotteen paneelien mattapuolen on oltava ulospäin!
Käytä tarvittaessa mietoa saippuaa profiilien ja paneelien liukumisen helpottamiseksi.
- Vaihe 22:** Suositellaan ruuvien #8192 asettamista valmisteluna hyllyjen asennukselle.
Jos olet hankkinut Tarvikevaja-hyllysarja, asenna enintään kaksi hyllyä pylvästä kohden.
Jos olet hankkinut Yukon vajan + Laajennuksen - siirry seuraavaan vaiheeseen.
- Vaihe 23:** Suositellaan ruuvien #8192 asettamista valmisteluna hyllyjen asennukselle.
Jos olet hankkinut Tarvikevaja-hyllysarja, asenna enintään kaksi hyllyä pylvästä kohden.
- Vaihe 32:** Ennen ruuvien asettamista varmista, että sisäpuoliset metalliprofiilit eivät tunkeudu esiin.
- Vaihe 33:** Ennen ruuvien asettamista varmista, että sisäpuoliset metalliprofiilit eivät tunkeudu esiin, ja että ne ovat hyvin kiinnitettyinä toisiinsa alumiiniprofilien sisällä.
- Vaihe 36:** Tarra on sijoitettava puhtaalle ja kuivalle pinnalle.
- Vaihe 45:** Hidasta ja varo liuuttaessasi paneeleja sisään.
- Vaihe 49:** Varmista, että etäisyys seinän alumiiniprofileiden ja kourun välillä on tasainen ennen kuin kiristät ruuvit sisäpuolelta.
- Vaihe 66:** Varmista, että vaha on suorassa ennen kuin ankkuroit sen valitsemaasi pintaan.
Käytä sopivia ruuveja ja tulppia (eivät sisälly toimitukseen).



VIGTIGE MONTERINGSTRIN

Når du støder på dette informationsikon under monteringen, se det relevante monteringstrin for vigtige yderligere kommentarer.

- Trin 1:** Hvis du har købt et **WPC Gulvsæt**, skal du ikke montere profil #8851!
- Trin 8:** Hvis du monterer et **WPC Gulvsæt**, skal du måle og skærer gulvbrættet #8912.
- Trin 19:** Den matte side på alle produktets paneler skal vende op ad!
Brug mild sæbe hvis det er nødvendigt for at lette samlingen af profiler og paneler.
- Trin 22:** Det anbefales at indsætte skruer #8192 som forberedelse til montering af hylde.
Hvis du har købt et **Hylde sæt til skur**, må du højst montere 2 hylde pr. stolpe.
Hvis du har købt **Yukon Skur + Forlænger** - skal du gå videre til næste trin.
- Trin 23:** Det anbefales at indsætte skruer #8192 som forberedelse til montering af hylde. Hvis du har købt et **Hylde sæt til skur**, må du højst montere 2 hylde pr. stolpe.
- Trin 32:** Sørg for, at de indvendige metalprofiler ikke stikker ud.
- Trin 33:** Sørg for, at de indvendige metalprofiler ikke stikker ud, før skruerne sættes i og er godt forbundet med hinanden inde i aluminiumprofilerne.
- Trin 36:** Klistermærket skal anbringes på en ren og tør overflade.
- Trin 45:** Gør det langsomt og vær forsigtig, når du skubber panelerne ind.
- Trin 49:** Kontroller, at afstanden mellem væggen aluminiumsprofiler og tagrende er identisk før du strammer skruerne på indersiden.
- Trin 66:** Sørg for, at skuret er i plan, før du fastgøre det til den ønskede overflade. Brug egnede skruer og dykker (medfølger ikke).



BELANGRIJKE STAPPEN VAN DE OPBOUW

Wanneer u dit informatiepictogram tijdens de opbouw tegenkomt, raadpleeg dan de betreffende stap van de opbouw voor belangrijke bijkomende opmerkingen.

- Stap 1:** Als u een **WPC-vloerkit** hebt gekocht, monteer dan profiel #8851 niet!
- Stap 8:** Als u een **WPC-vloerkit** installeert, meet en snijdt u vloerplaat #8912.
- Stap 19:** Matte zijde van alle panelen van het product moet naar buiten gericht zijn!
Gebruik indien nodig milde zeep om het glijden van profielen en panelen te vergemakkelijken.
- Stap 22:** Het wordt aanbevolen om schroeven #8192 aan te brengen als voorbereiding voor het monteren van planken. Als u een **Schappensets** hebt aangeschaft, kunt u maximaal 2 planken per paal plaatsen.
Als u de **Yukon Shed + uitbreiding** hebt aangeschaft, gaat u naar de volgende stap.
- Stap 23:** Het wordt aanbevolen om schroeven #8192 aan te brengen als voorbereiding voor het monteren van planken. Als u een **Schappensets** hebt aangeschaft, kunt u maximaal 2 planken per paal plaatsen.
- Stap 32:** Voordat u de schroeven installeert, moet u ervoor zorgen dat de interne metalen profielen niet uitsteken.
- Stap 33:** Voordat u de schroeven installeert, moet u ervoor zorgen dat de interne metalen profielen niet uitsteken en goed met elkaar zijn verbonden binnen de aluminium profielen.
- Stap 36:** De sticker moet op een schoon en droog oppervlak worden geplaatst.
- Stap 45:** Doe rustig aan en wees voorzichtig bij het inschuiven van de panelen.
- Stap 49:** Zorg ervoor dat de afstand tussen de aluminium profielen en goot van de muur identiek is voordat de schroeven aan de binnenkant worden vastgedraaid.
- Stap 66:** Zorg dat de schuur waterpas staat voordat u hem op het oppervlak van uw keuze verankert. Gebruik geschikte schroeven en pluggen (niet meegeleverd).



FASI DI MONTAGGIO IMPORTANTI











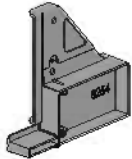





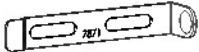

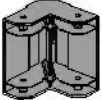

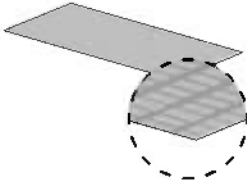

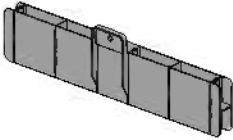

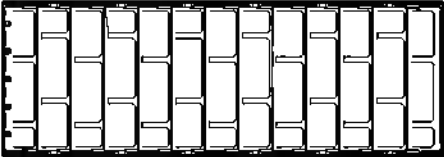
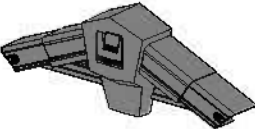
Quando si incontra questa icona informativa durante il montaggio, fare riferimento alla relativa fase di montaggio per ulteriori importanti commenti.

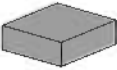
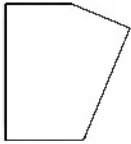
- Passo 1:** se hai acquistato un kit da **pavimento WPC**, non assemblare il profilo **#8851!**
- Passo 8:** se si installa un kit da **pavimento WPC**, misurare e tagliare il pannello per pavimento **#8912**.
- Passo 19:** il lato opaco di tutti i pannelli del prodotto deve essere rivolto verso l'esterno! Usa sapone neutro se necessario per facilitare lo scorrimento di profili e pannelli.
- Passo 22:** Si consiglia di inserire le viti **#8912** come preparazione per i ripiani di montaggio. Se hai acquistato un **kit scaffale**, montare un massimo di 2 ripiani per post. Se hai acquistato l'estensione **Yukon Shed + vai** al passaggio successivo.
- Passo 23:** Si consiglia di inserire le viti **#8912** come preparazione per i ripiani di montaggio. Se hai acquistato un kit scaffale, montare un massimo di 2 ripiani per post. Prima di inserire le viti, assicurarsi che i profili metallici interni non sporgano.
- Passo 32:** Prima di inserire le viti, assicurarsi che i profili metallici interni non sporgano.
- Passo 33:** Prima di inserire le viti, assicurarsi che i profili metallici interni non sporgano e sono ben connessi l'un l'altro all'interno dei profili di alluminio
- Passo 36:** L'adesivo deve essere piazzato su una superficie pulita e asciutta.
- Passo 45:** Rallentare e fare attenzione quando si fanno scivolare i pannelli all'interno
- Passo 49:** Assicurarsi che la distanza tra i profili in alluminio dei muri e la grondaia sia identica prima di stringere le viti all'interno.
- Passo 66:** Assicurarsi che il pannello sia livellato prima dell'ancoraggio alla superficie scelta. Usa viti e cavi adatti (non inclusi)

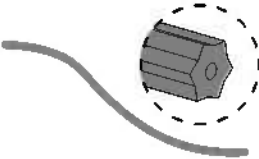
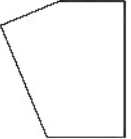

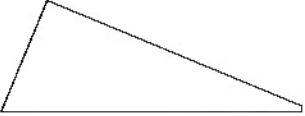

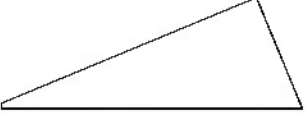





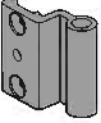

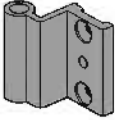
Contents

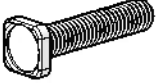
Item	Qty.	Item	Qty.	Item	Qty.
8835	2	9018	2	256	8
8836	1	8844	1	9020	2
8837	1	8842	1	8913	2
8840	4	8845	4	9027	1
9016	1	8850	1	8867	4
8846	4	8851	1	8866	2
8838	2	8834	4	8853	2
8839	19	8847	4	9024	2
		8833	6	8854	1
		8848	2	8855	1

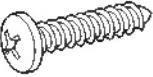
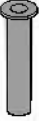
Contents

Item		Qty.	Item		Qty.	Item		Qty.	Item		Qty.
8858		6	8254		1	8782		4	7870		2
9029		8	8255		1	8781		4	7871		2
8859		4	7602		4	8786		4	8884		4
8864		8	8447		1	8785		2			
9030		8	8789		2	8779		1	8883		4
8862		2	8787		2	8778		1	8885		2
8863		2	8788		2	8274		2			
8860		2	8784		1	9227		12			
8861		2	8783		1						

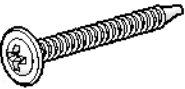
Contents

Item		Qty.	Item		Qty.
466		112 (+11)	7919		4
411		81 (+7)	7918		4
8192		25 (+3)	7921		4
7284		2	7920		4
8422		2	7923		8
4045		68 (+6)	7922		4
7442		32 (+2)	7924		16
7524		20 (+2)			
4008		12 (+1)			
8635		4			

Contents Extension Kit

Item	Qty.	Item	Qty.
8839	4		
9023	4	466	42 (+2)
9017	1	411	36 (+2)
9021	1	8192	6
9022	1	4045	12 (+1)
9019	2	7442	16 (+1)
9028	1	9227	2
9734	2	8447	2
		7985	5
		100	2

Item	Qty.
	
8912	18

Floor Kit
11'x9'

Item	Qty.
	
8912	9

Floor Extension Kit
11'x4'

9029	4
9030	4

1



If you've purchased a **WPC Floor Kit**, do not assemble profile #8851!



8850



1

8851

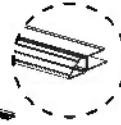

1

4045



2

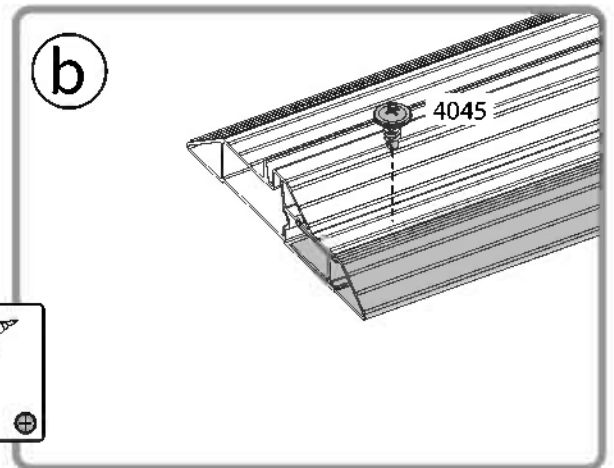
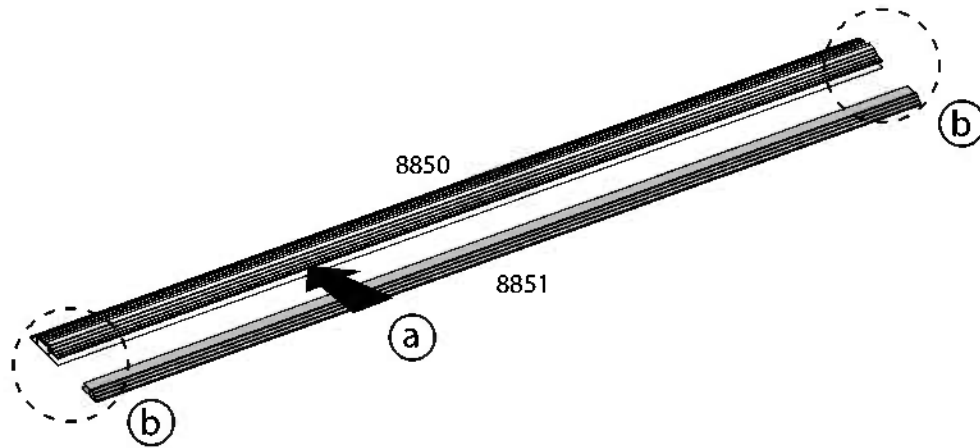
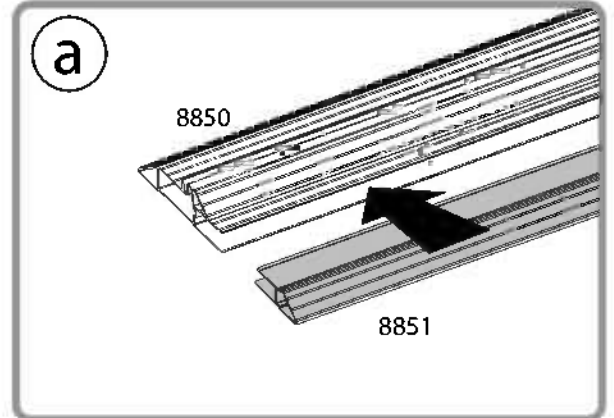

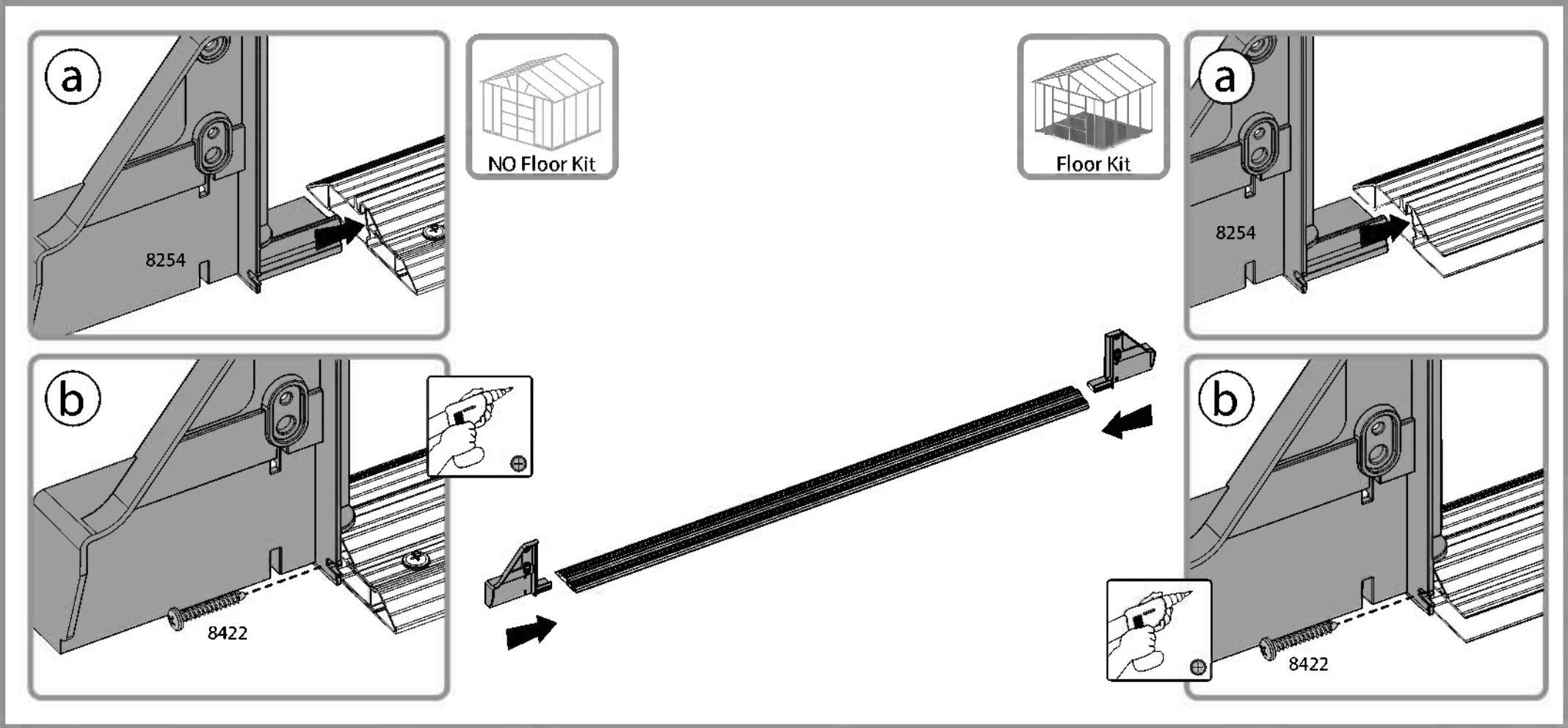
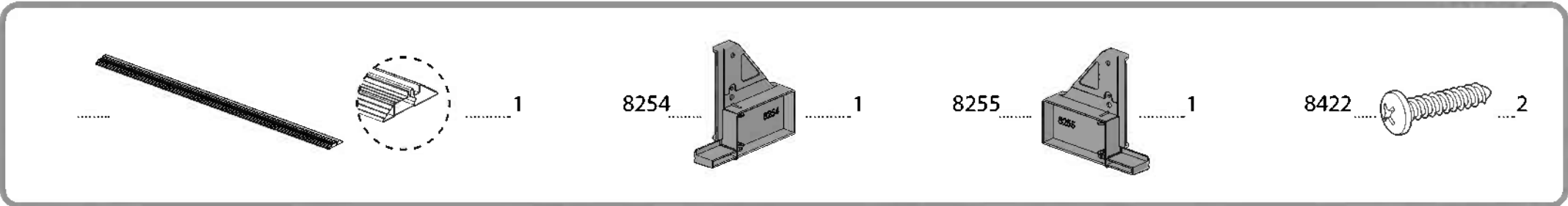

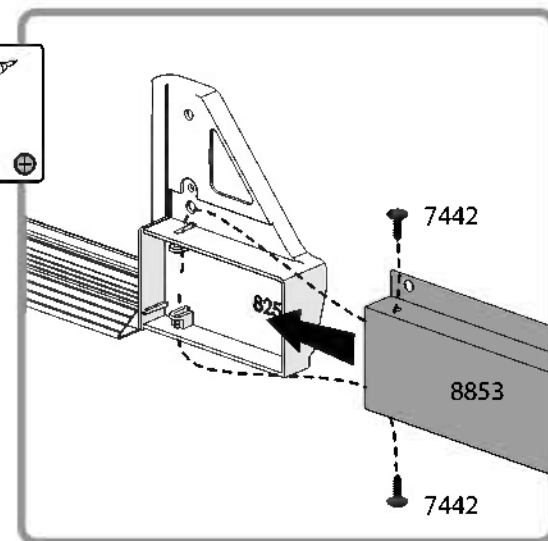
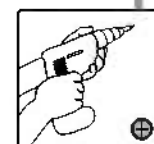
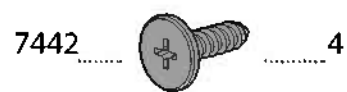

3

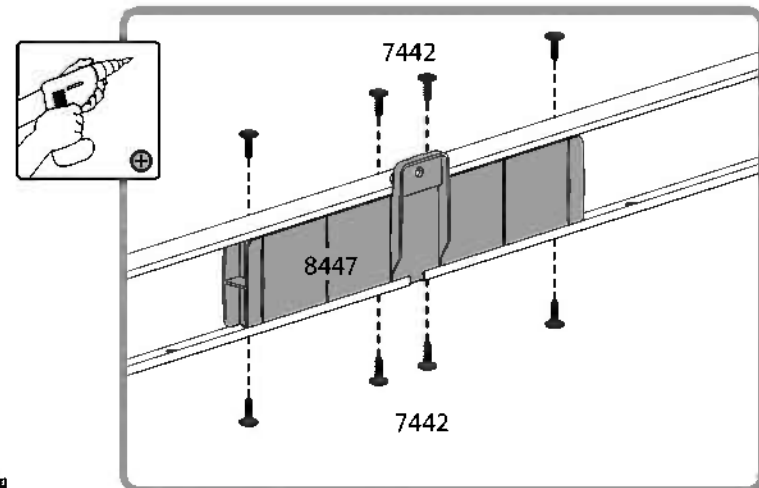
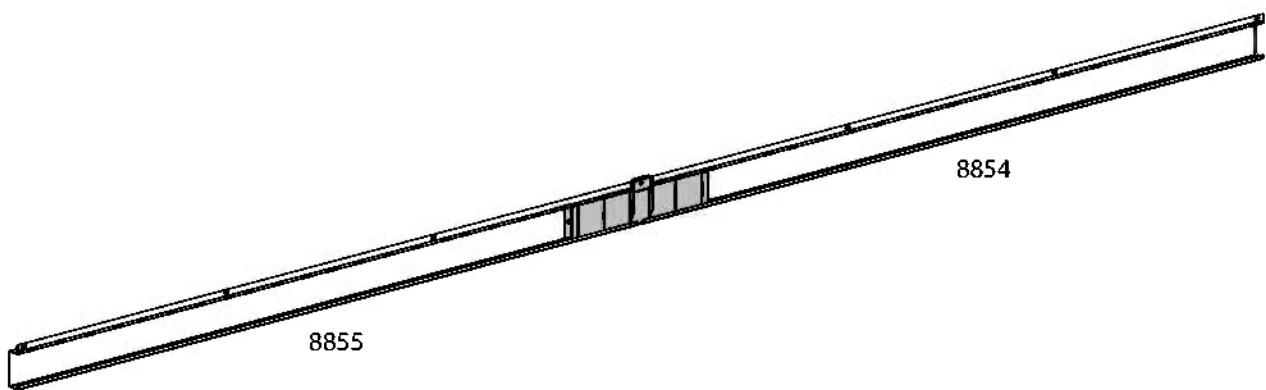
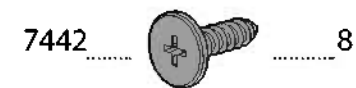
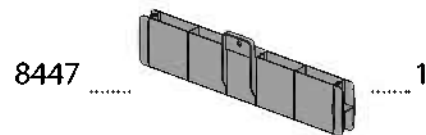
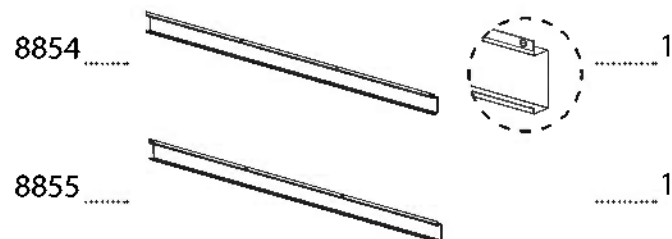



5 For Extension Kit Only

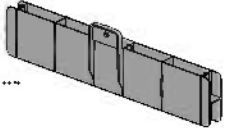

- 9024  2
- 9734  2
- 7442  16
- 8447  2



Extension Kit

11'x13'
11'x9' + 11'x4'

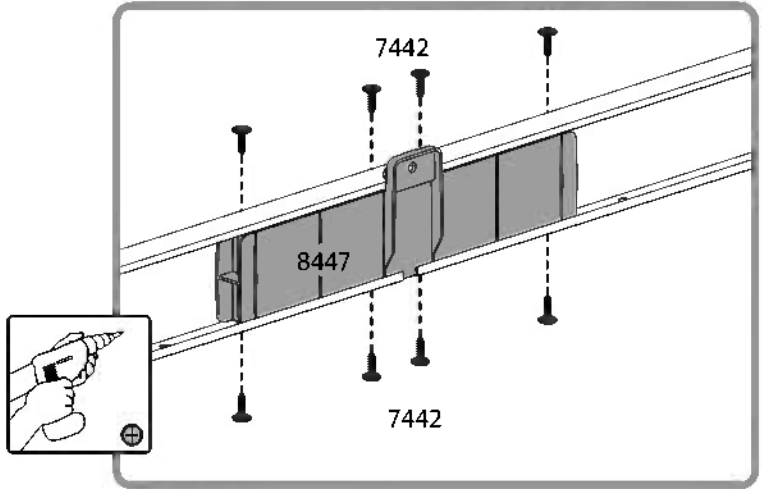
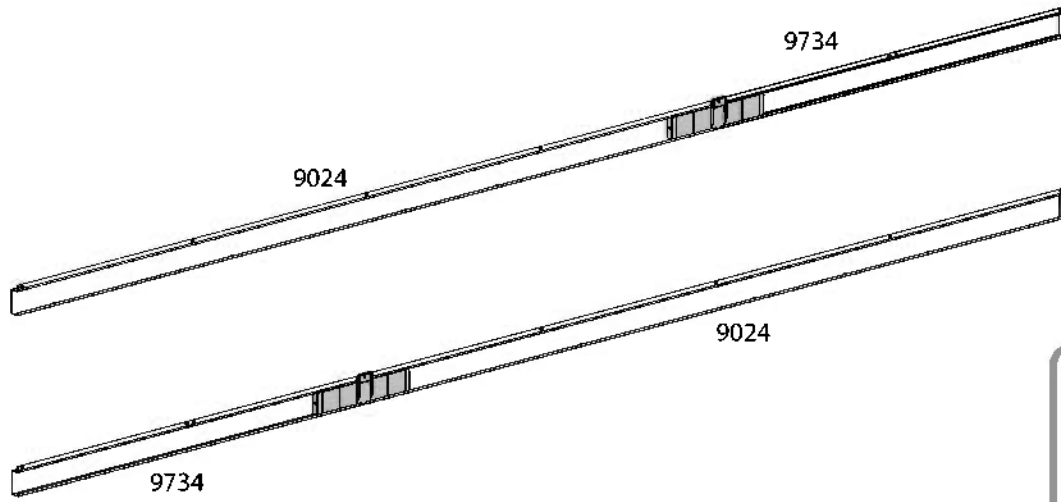

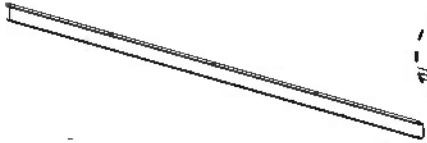

9024  2

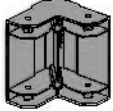
7602  4

7442  16

x4

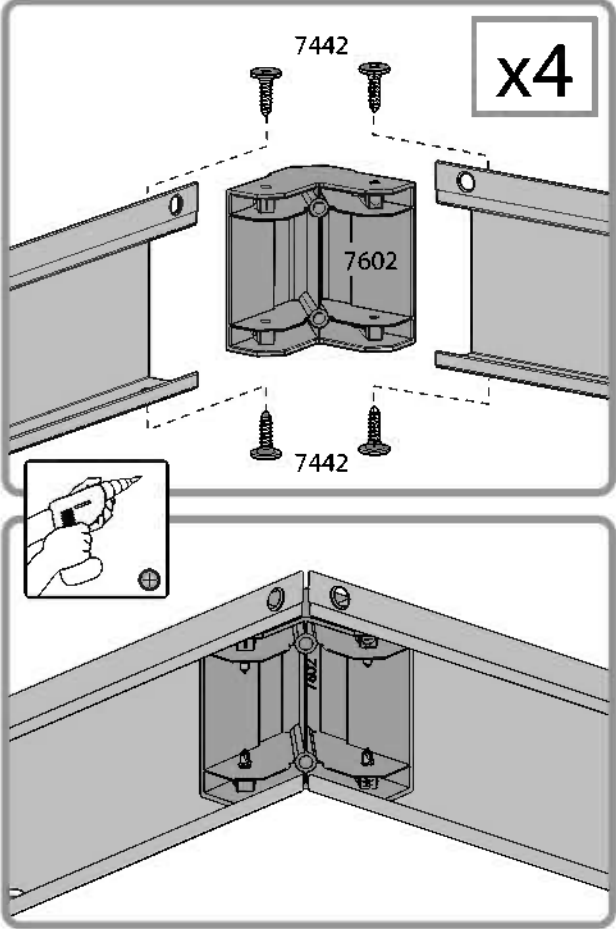

7442

7602

7442

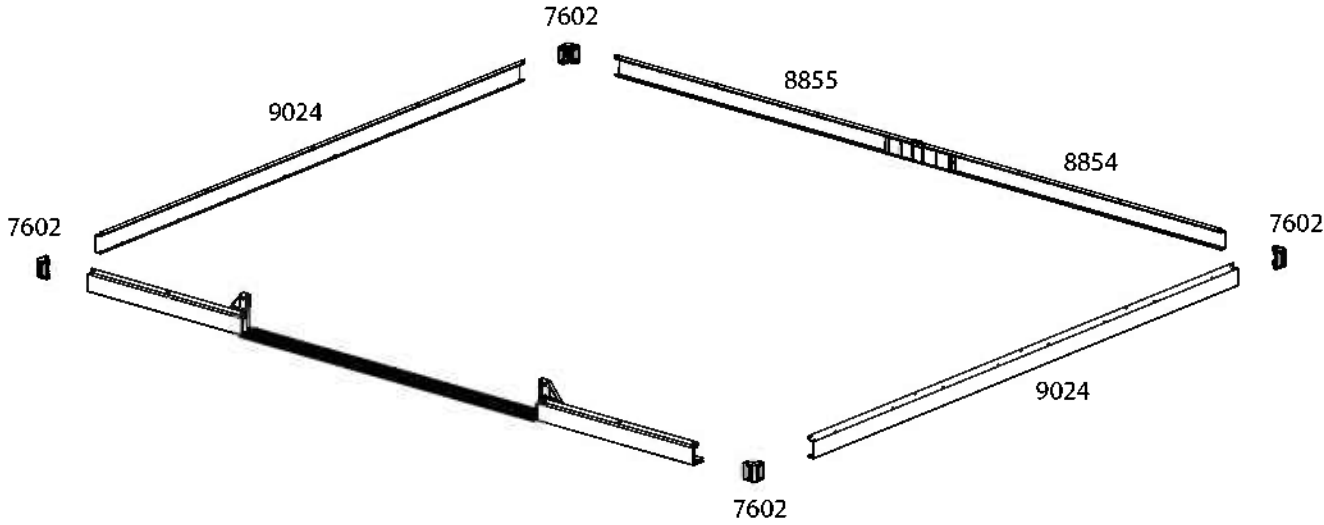

9024

7602

8855

8854

7602

9024

7602

7602

Extension Kit

9734

9024

9734

9024

7 For Floor Kit Only



8912

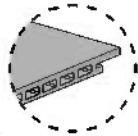
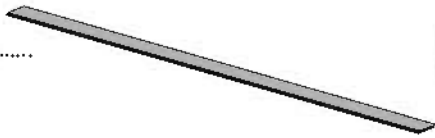

..... 17



Floor Extension Kit

8912..... 9



Floor Kit

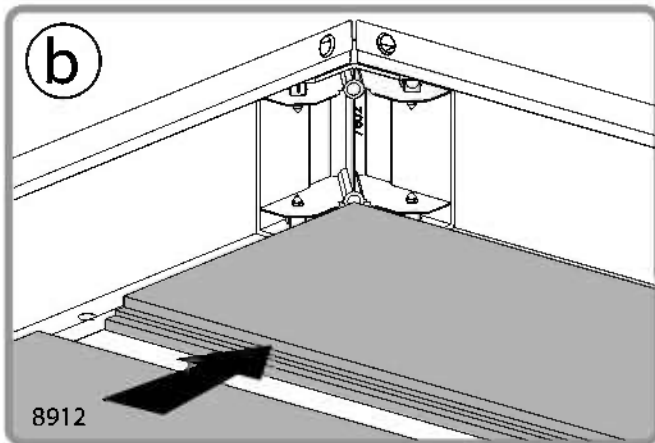
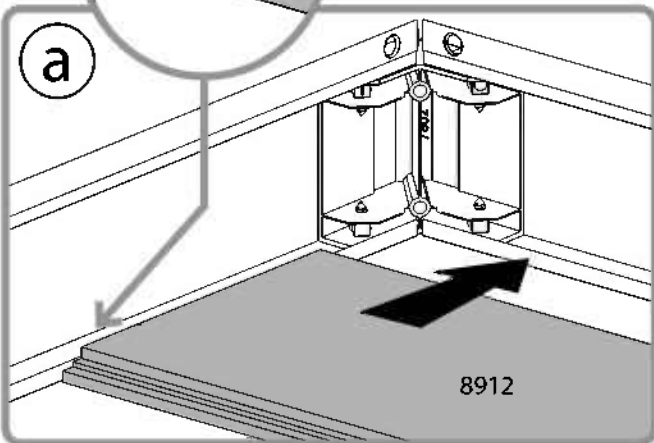
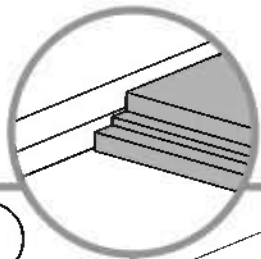
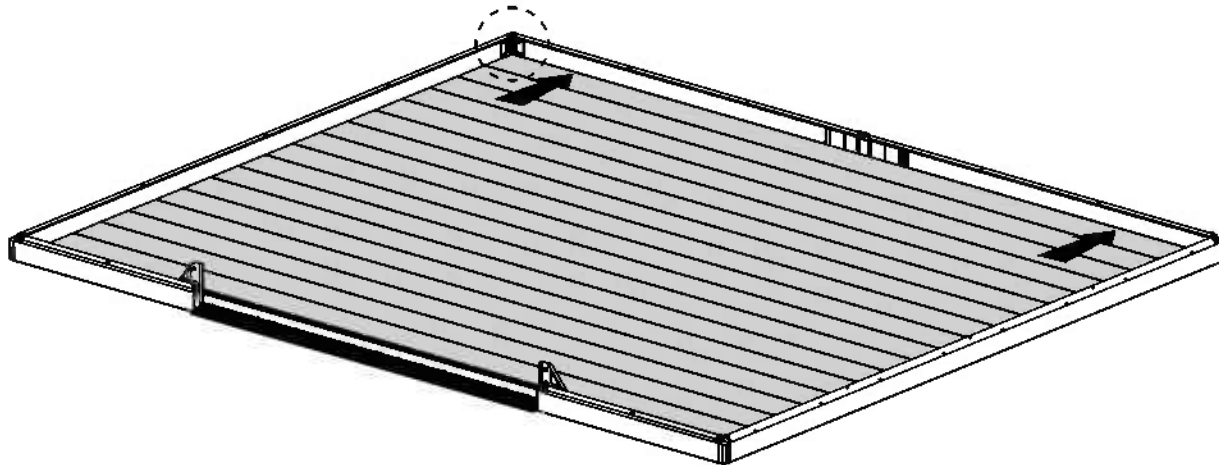

Floor Extension Kit

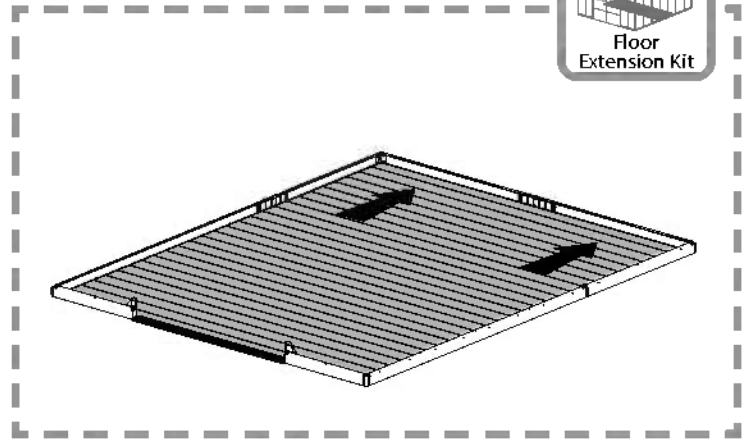

8 **i** Only Floor Kit

If you're installing a **WPC Floor Kit**, measure and cut floor board #8912.

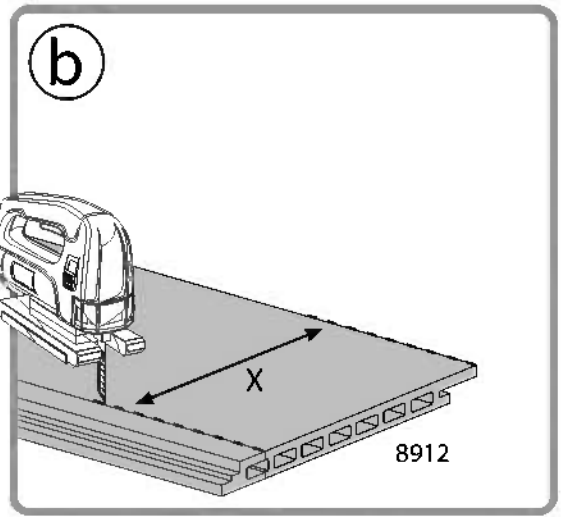
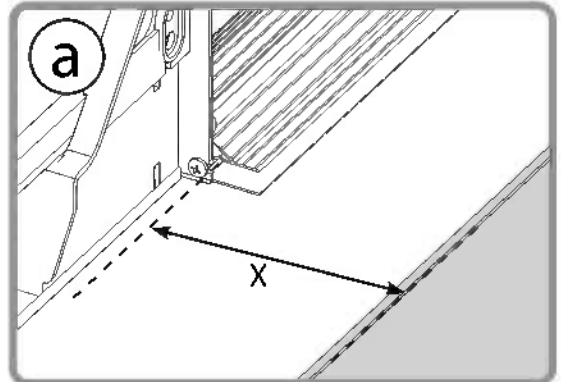
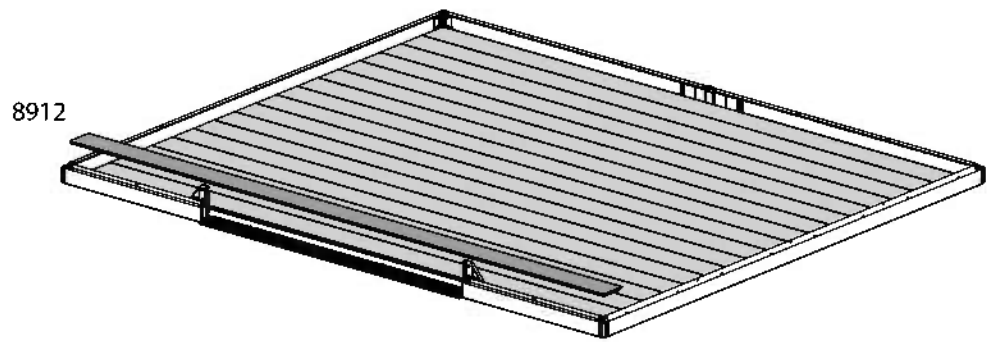
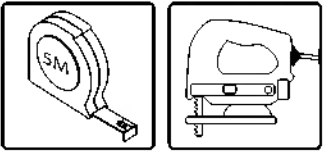
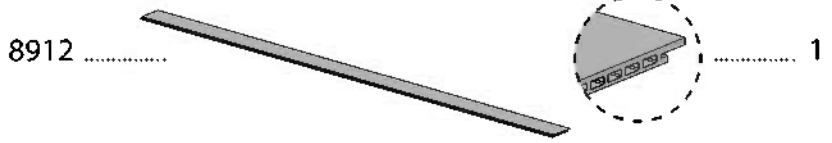

9 For Floor Kit Only

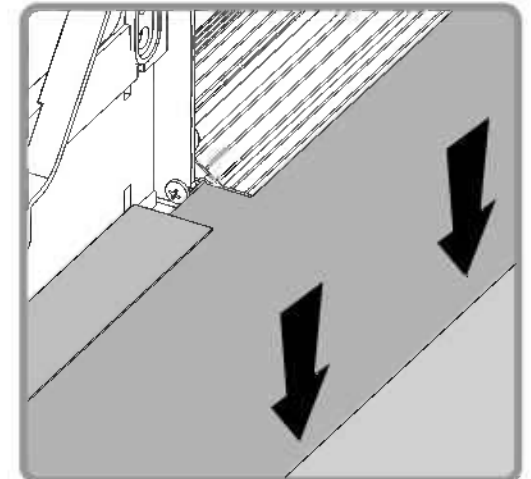
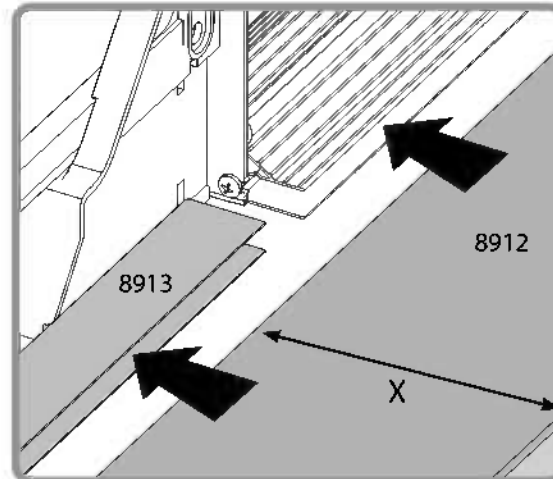
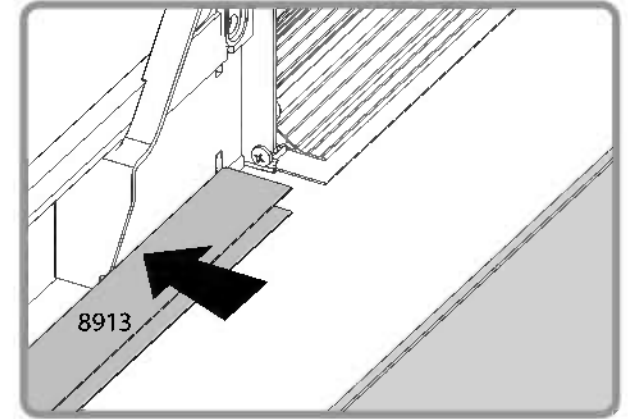
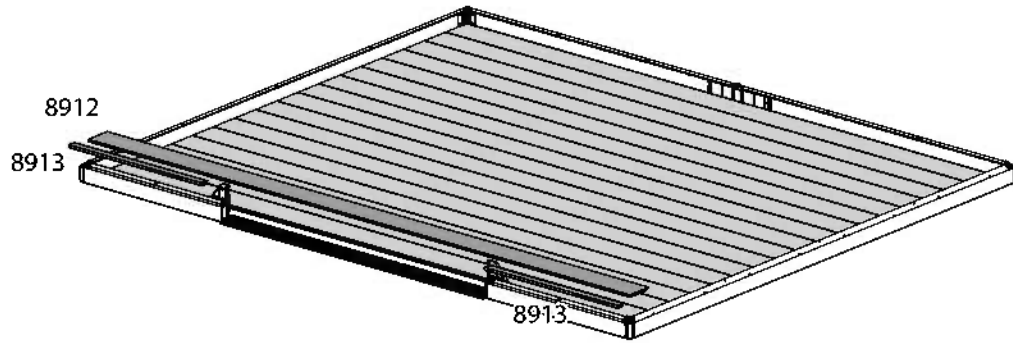
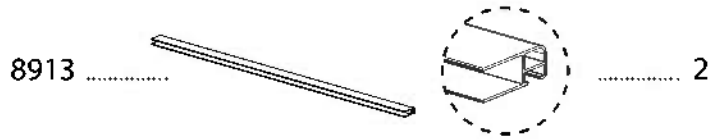

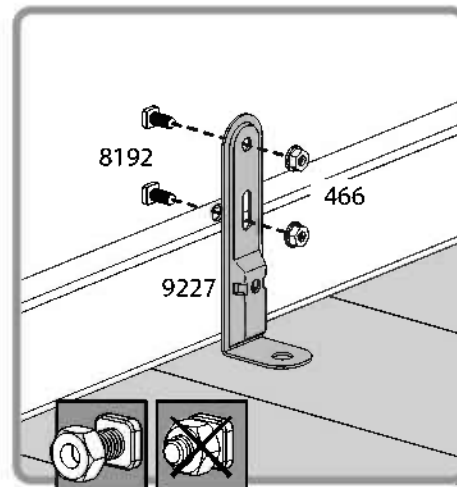
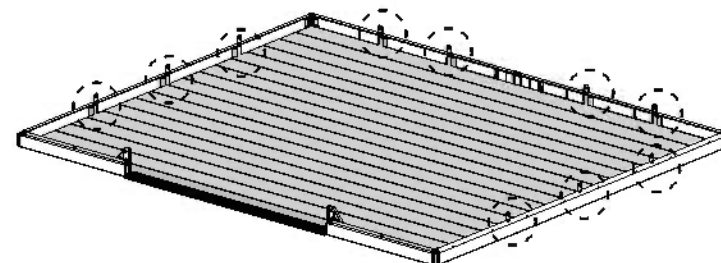
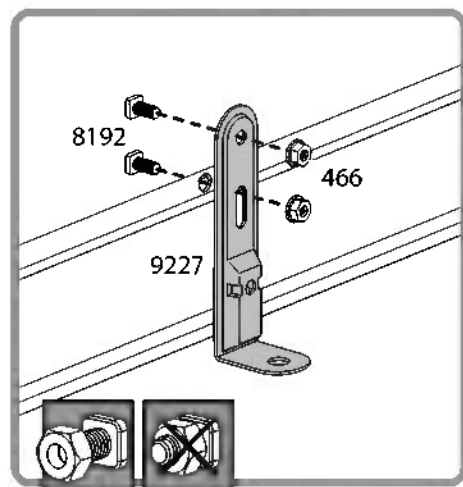
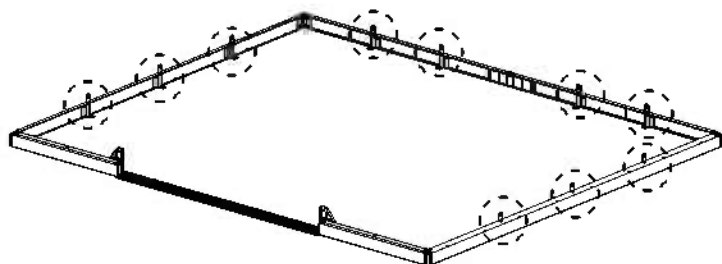
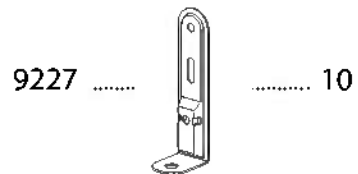

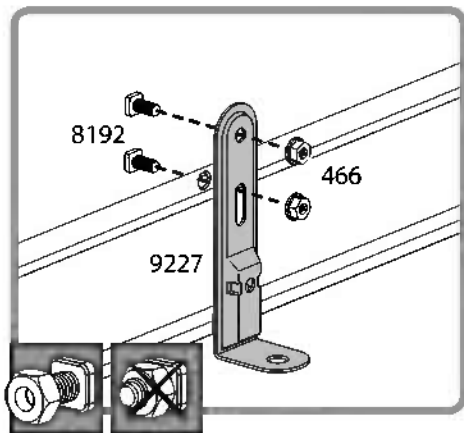
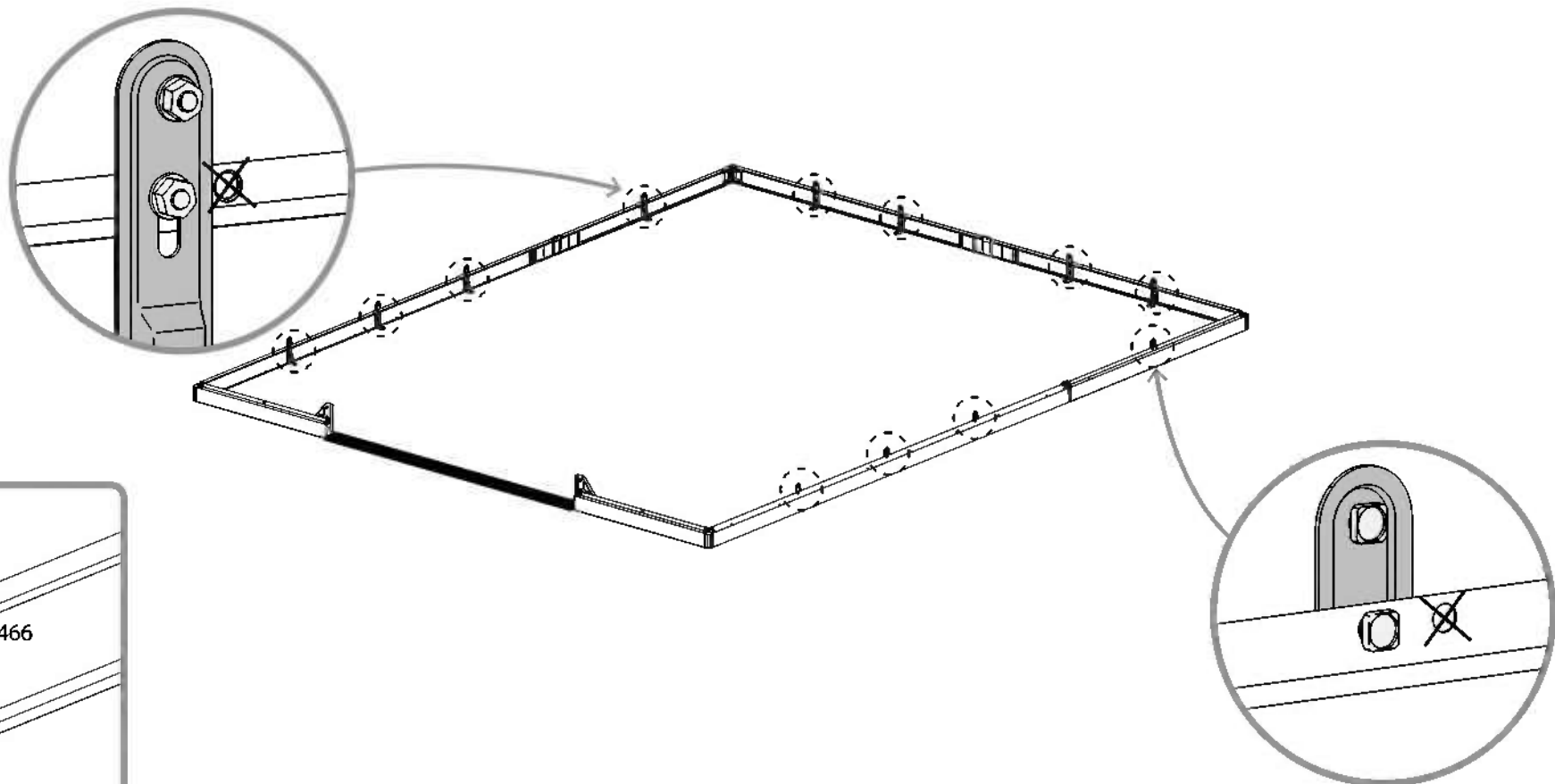
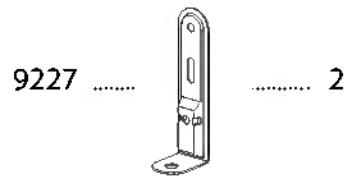
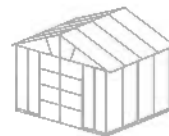



8192 3

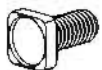

466 3



8192 2

466 2

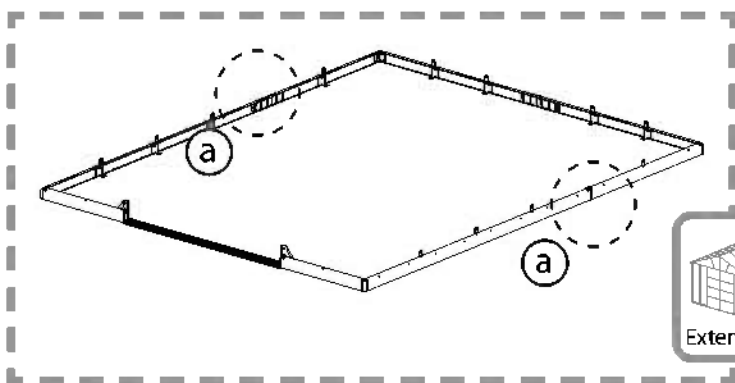
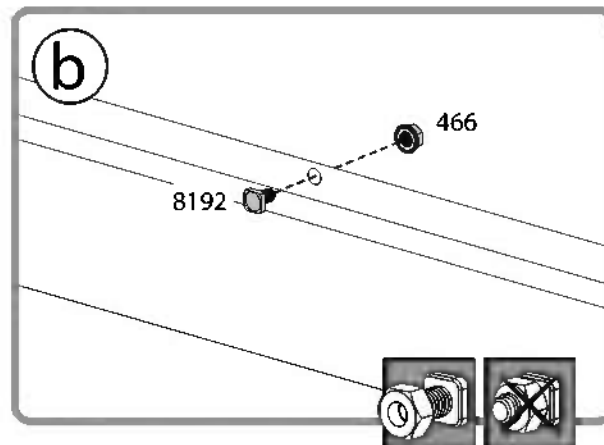
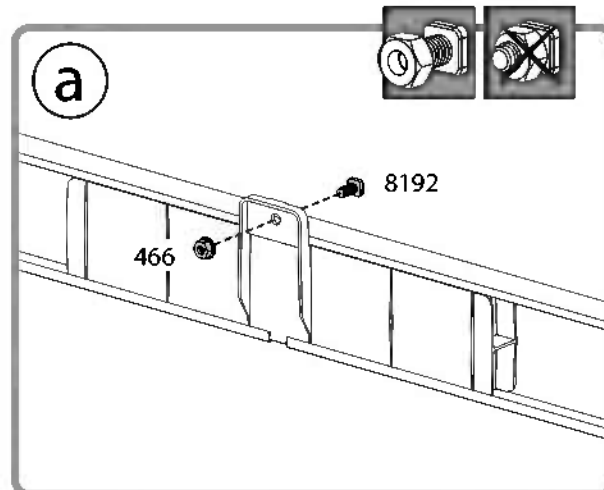
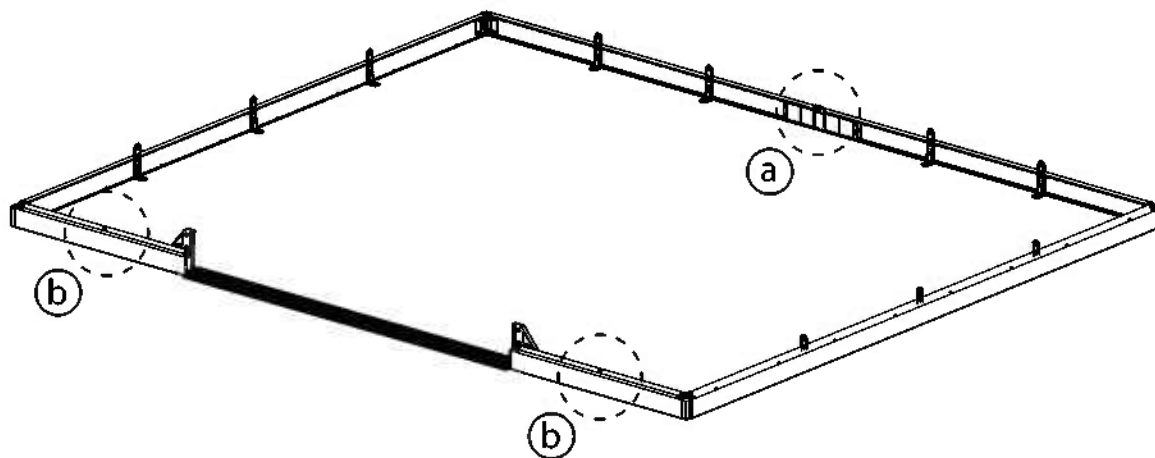

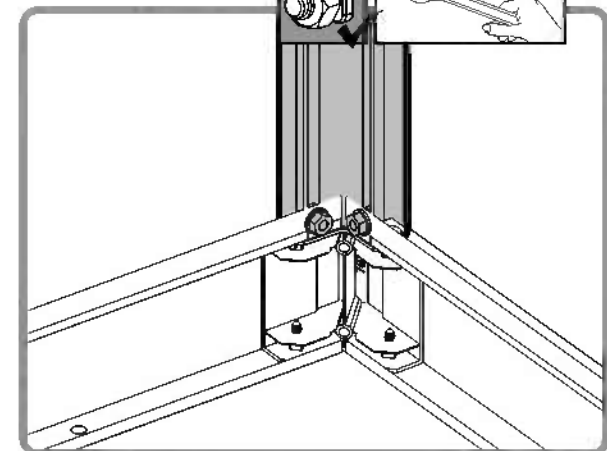
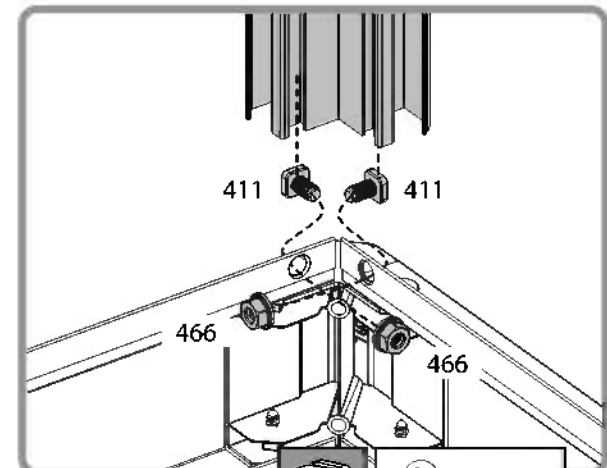
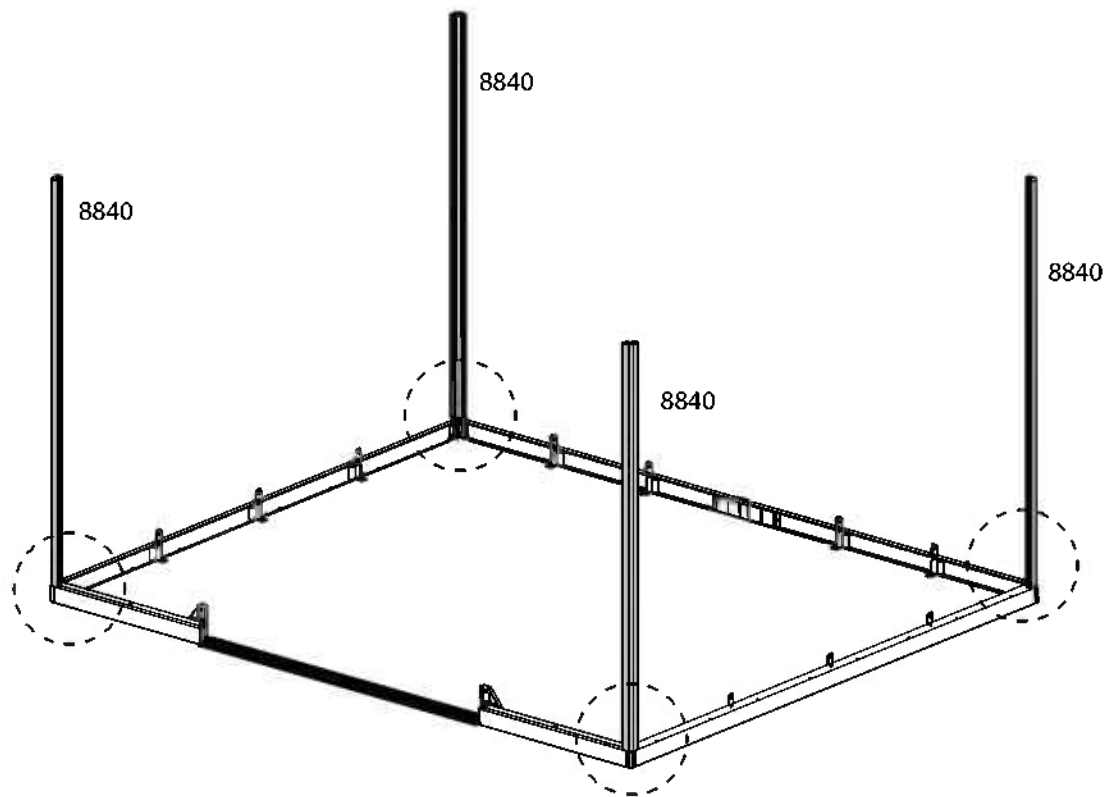
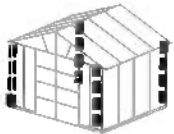

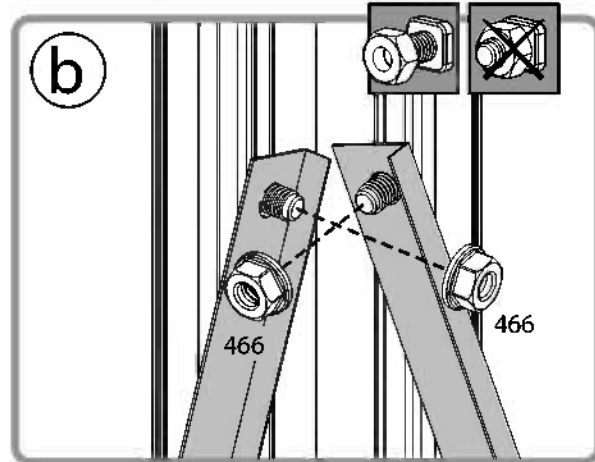
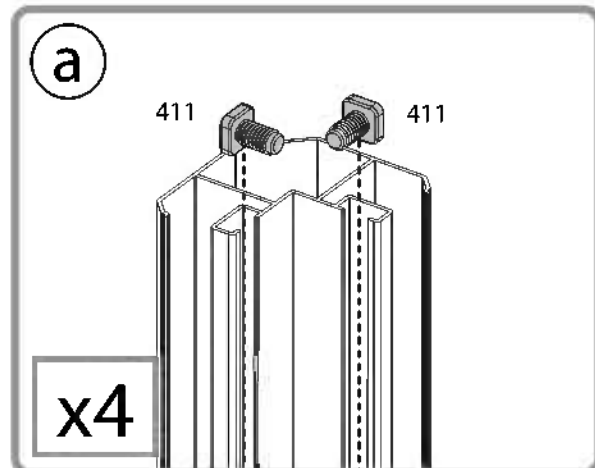
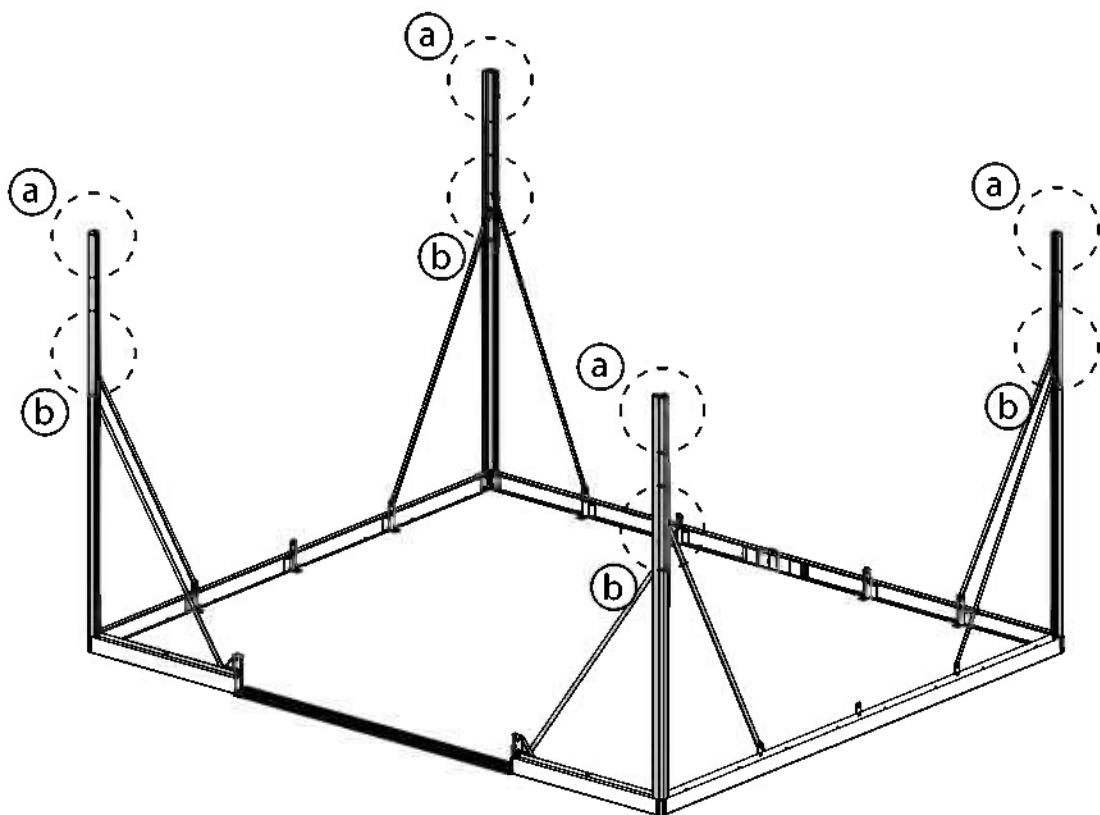

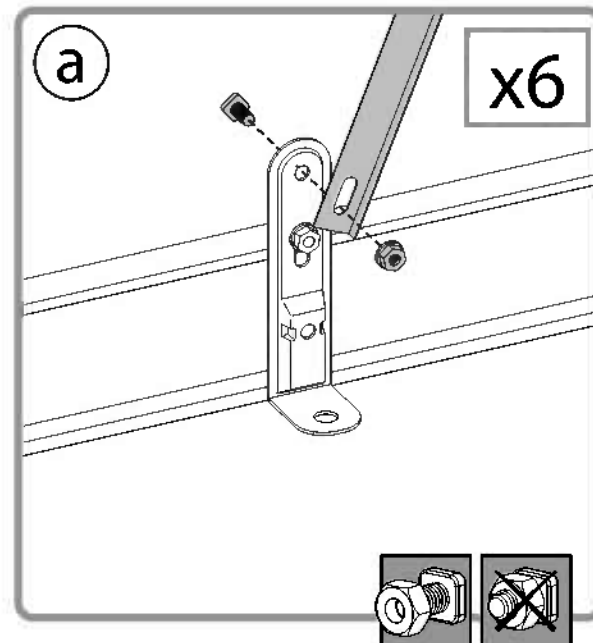
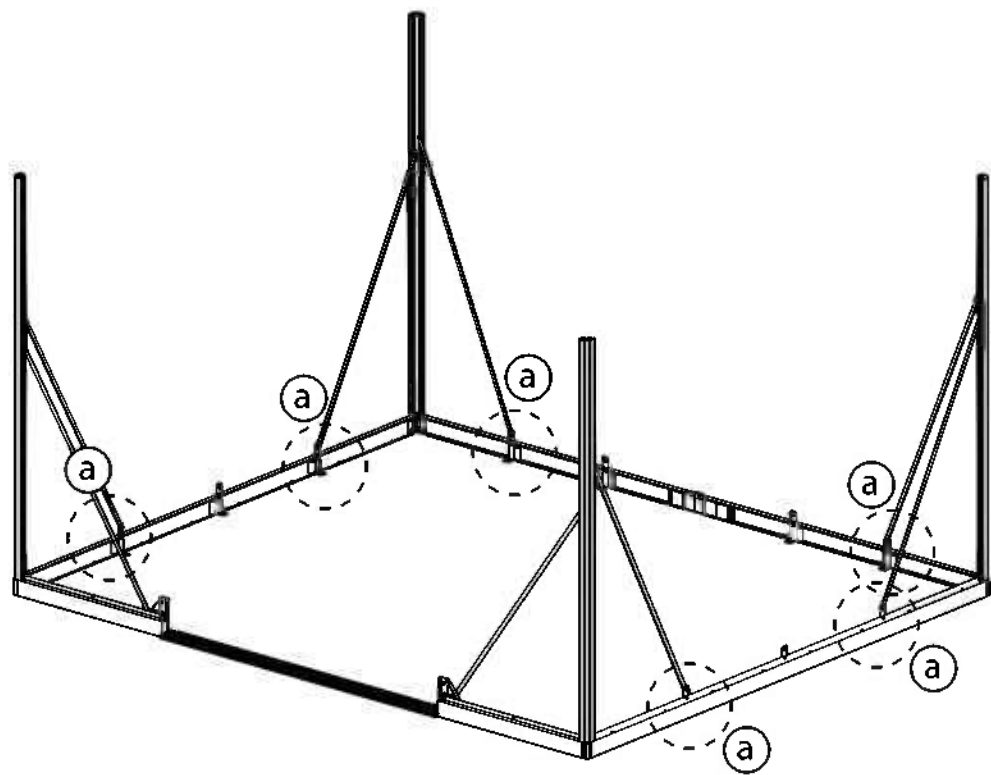

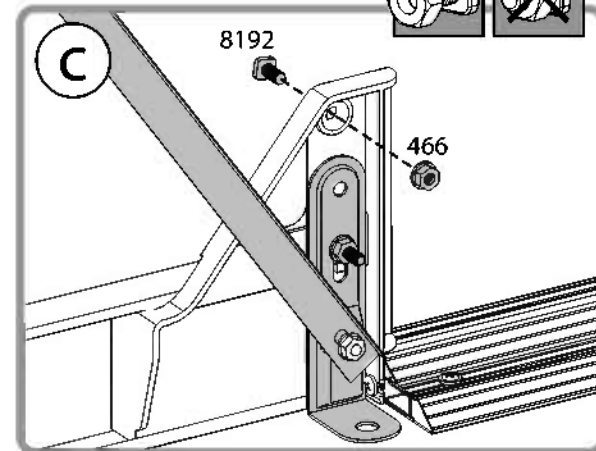
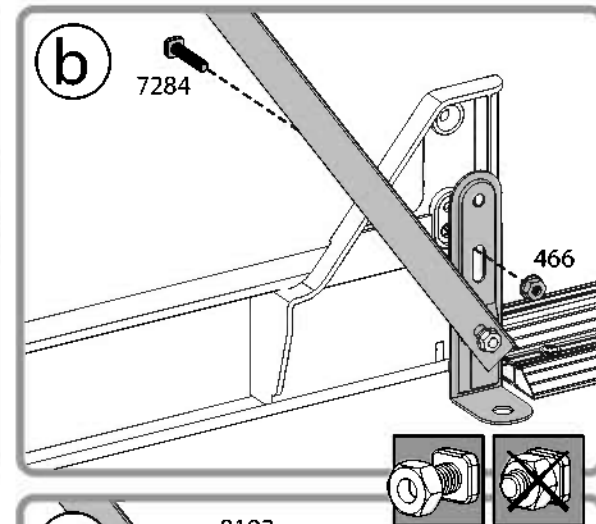
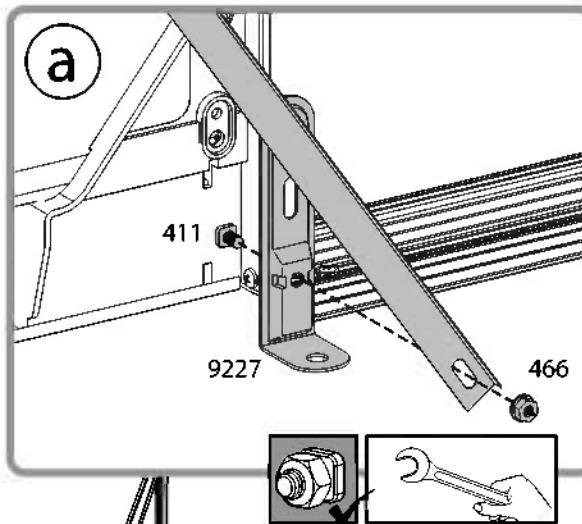
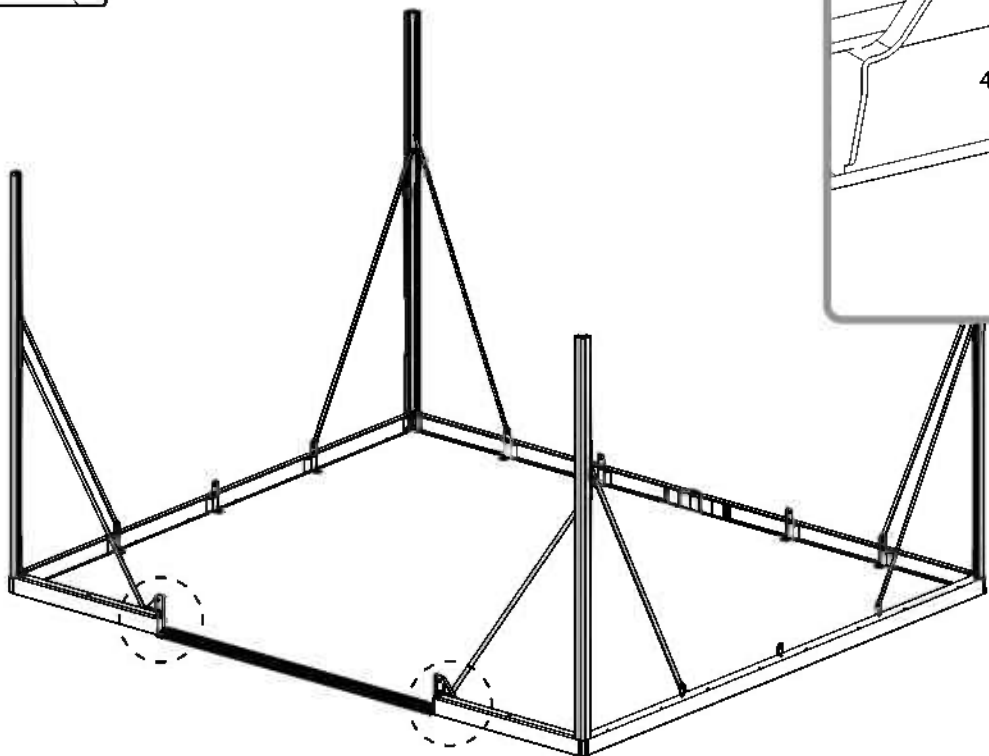
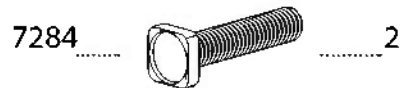
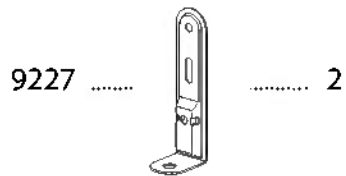
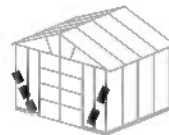

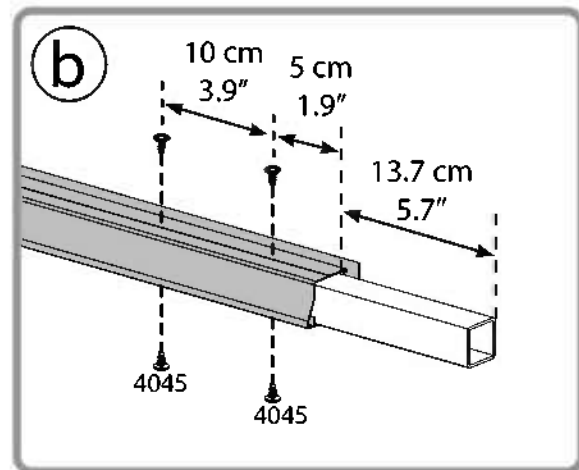
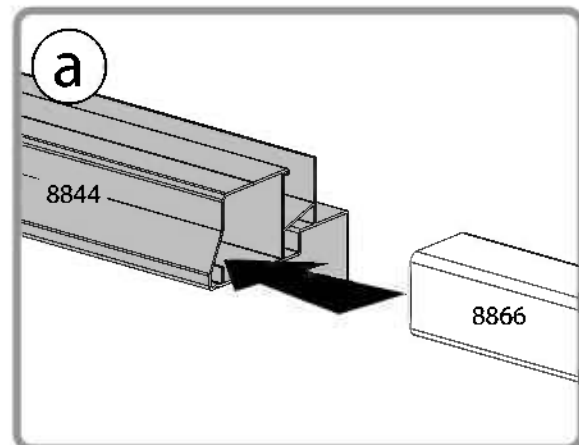
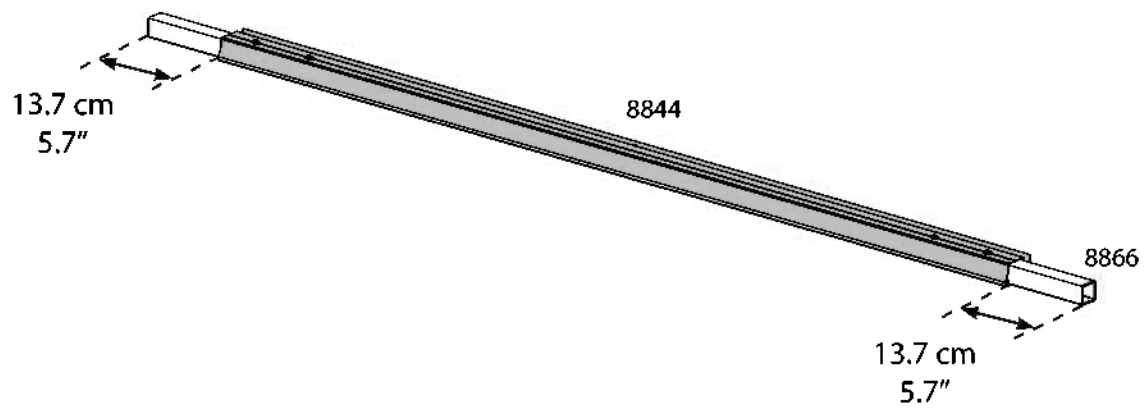
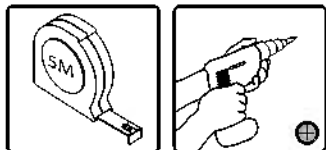
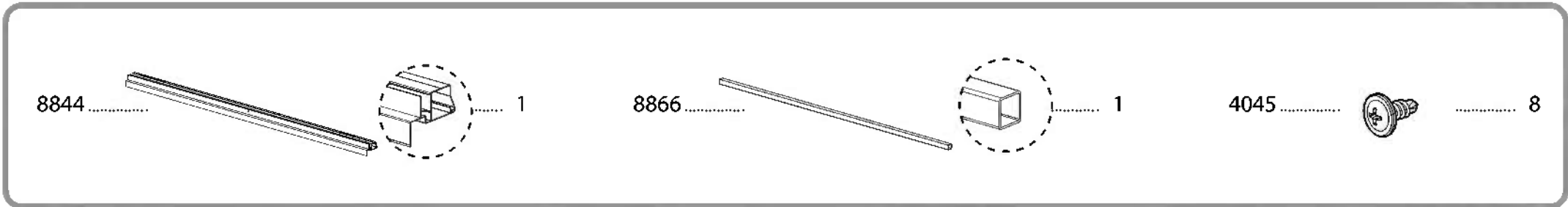





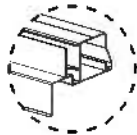

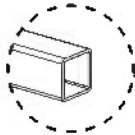

8845   2

8867   2

4045  12

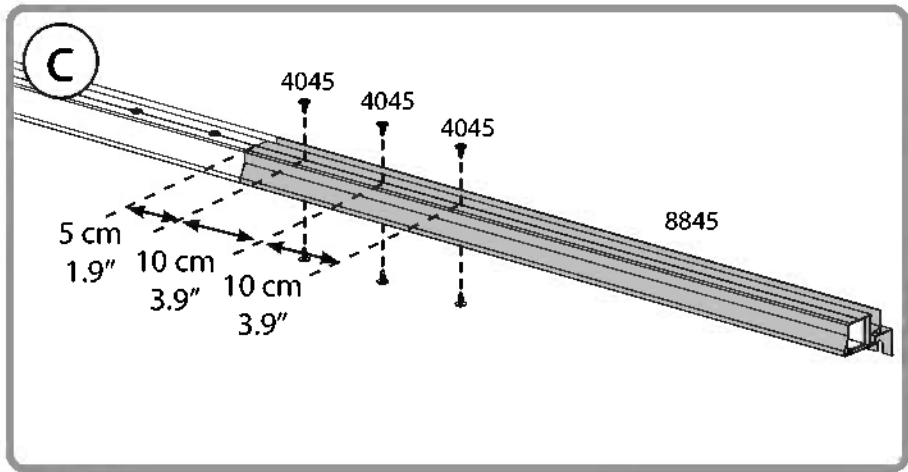
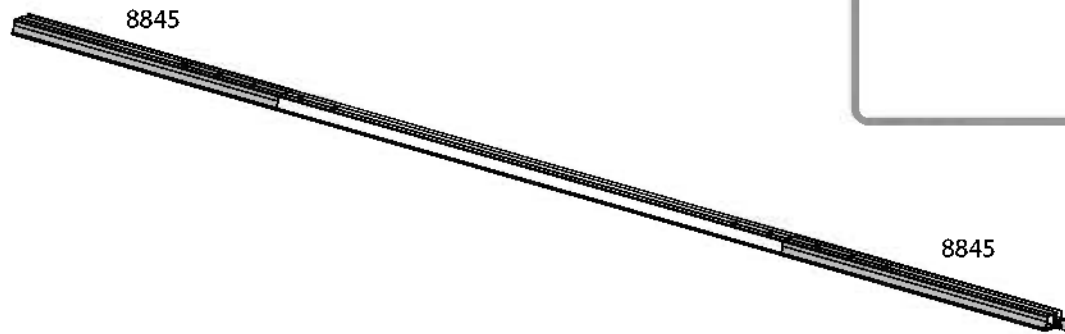
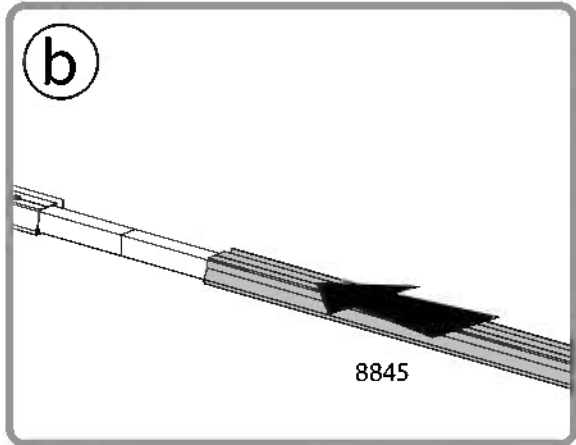
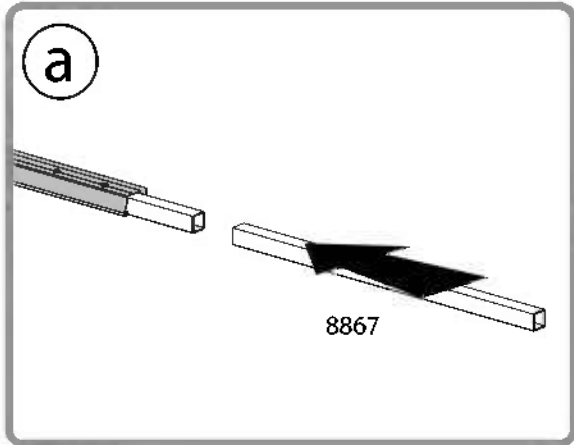
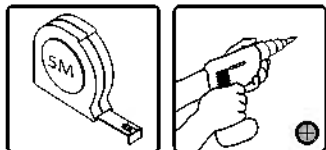

19



Matte side of all product's panels should be facing out!
Use mild soap if needed to ease sliding of profiles & panels

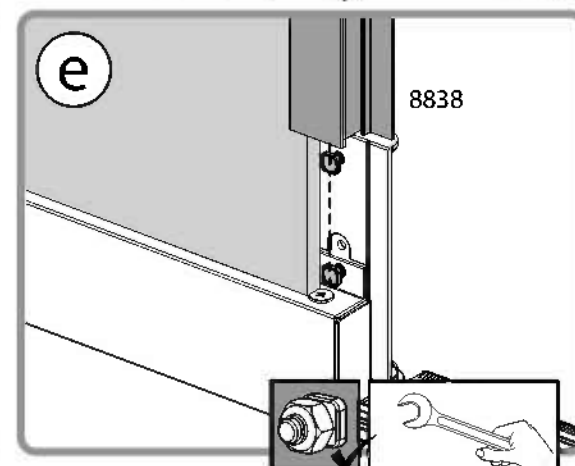
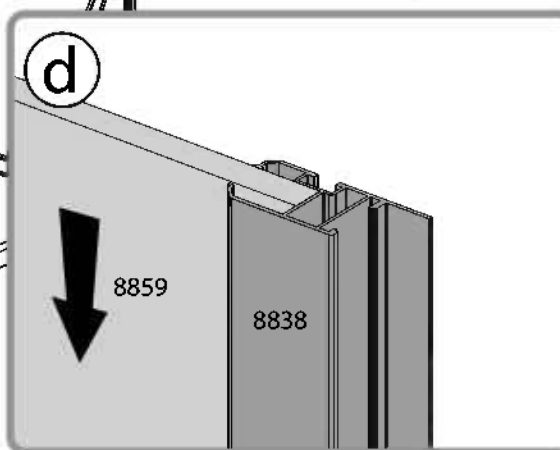
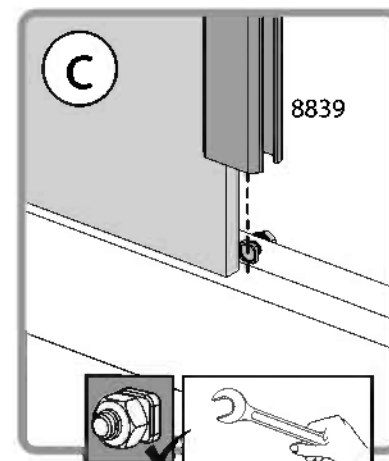
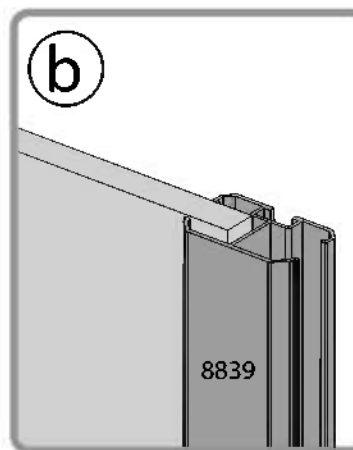
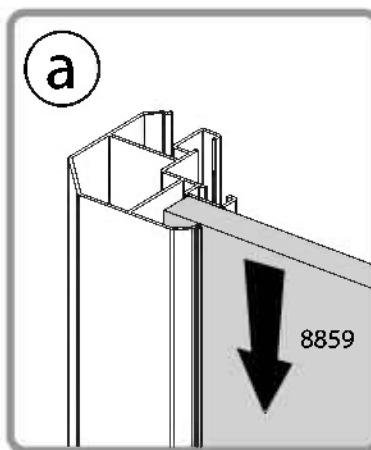
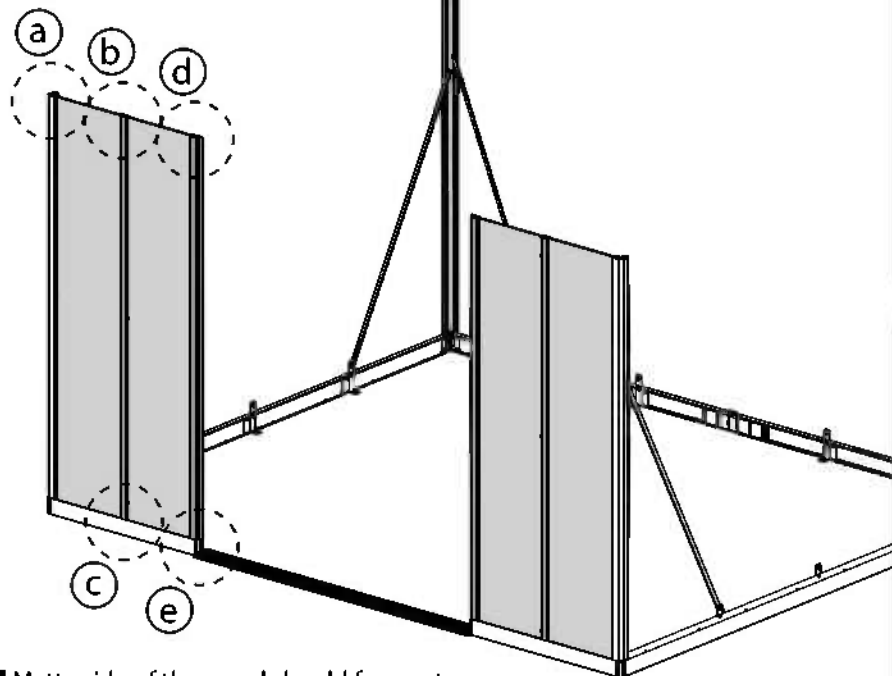
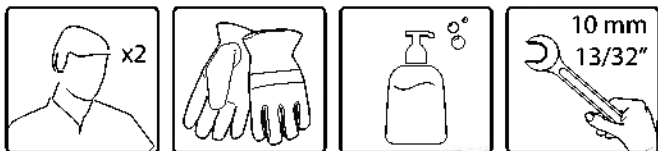
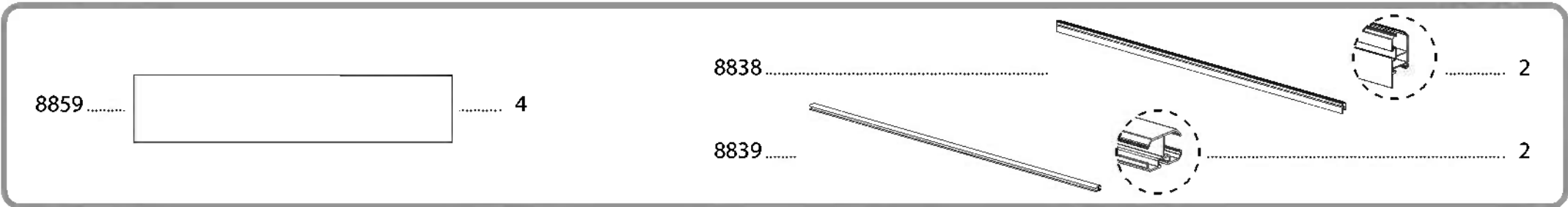

EN Matte side of the panel should face out
DE Die matte Seite aller Produktplatten sollte nach immer außen verlegt werden
FR Le côté mat de tous les panneaux du produit devrait être tourné vers l'extérieur
SP El lado mate de todos los paneles del producto debe estar mirando hacia afuera

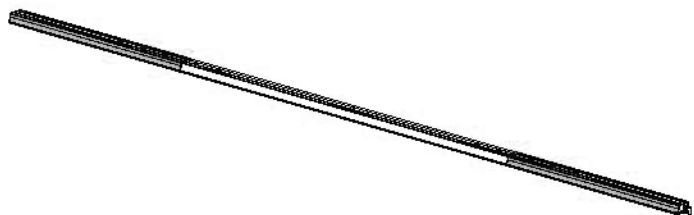

411 6



466 6

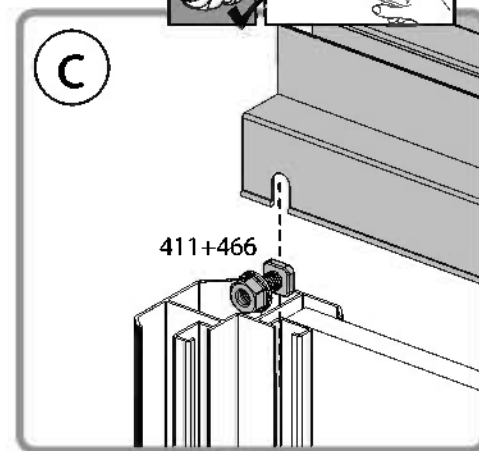
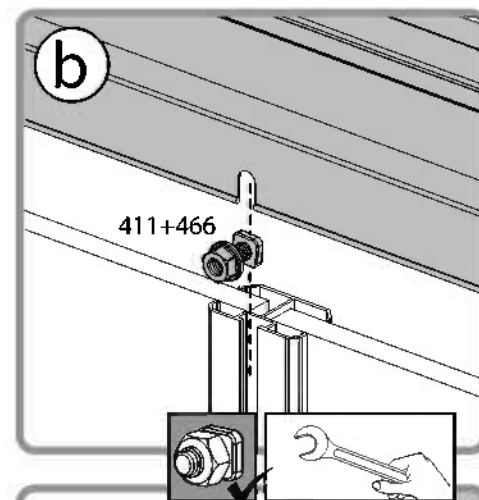
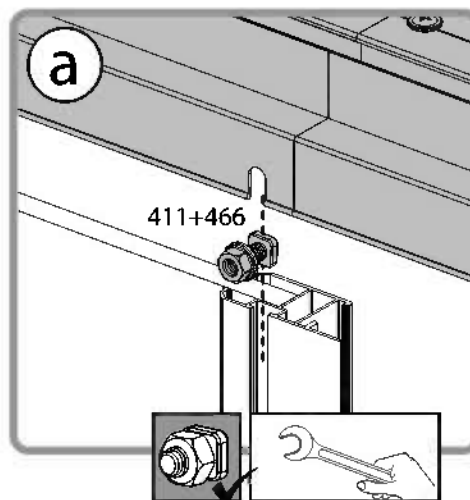
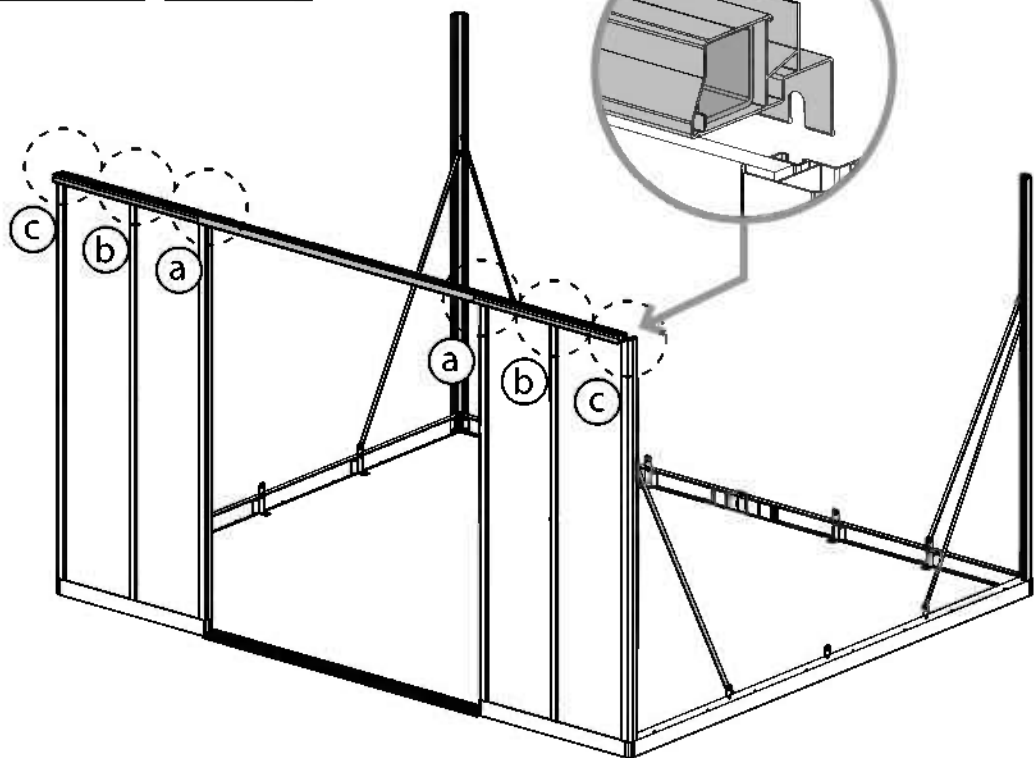
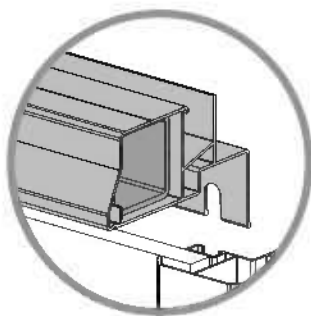
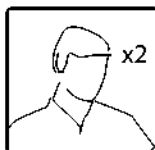

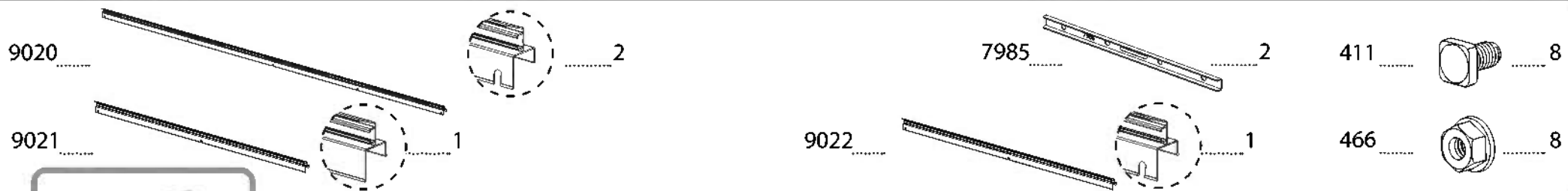

11'x13'
11'x9' + 11'x4'

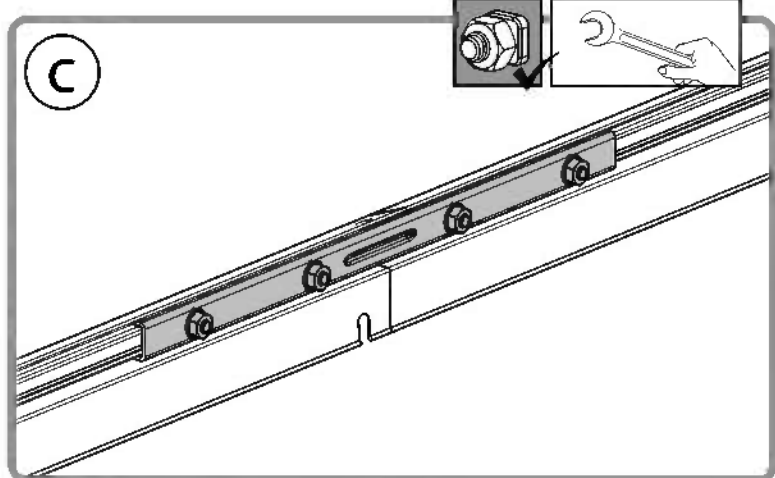
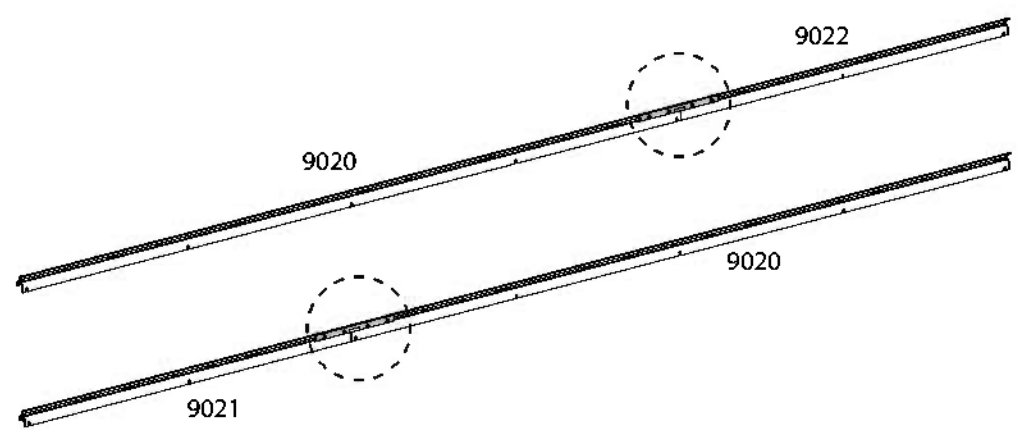
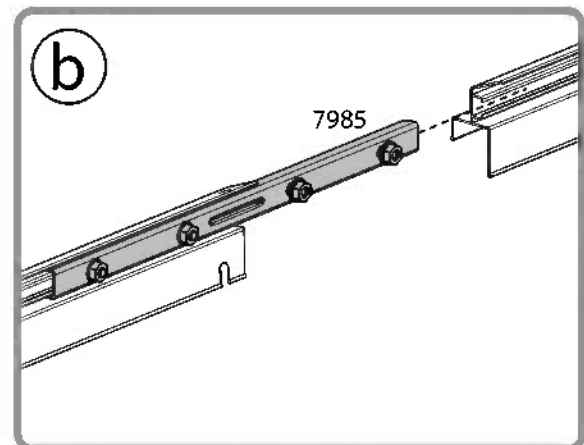
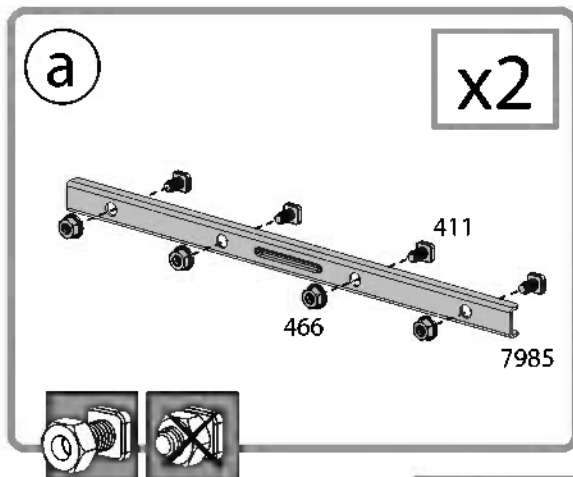

22



It is recommended to insert screws #8192 as preparation for mounting shelves. If you've purchased a shelf kit, mount a maximum of 2 shelves per post. If you have purchased the Yukon Shed + Extension - go to the next step.



8839



3

9029



4

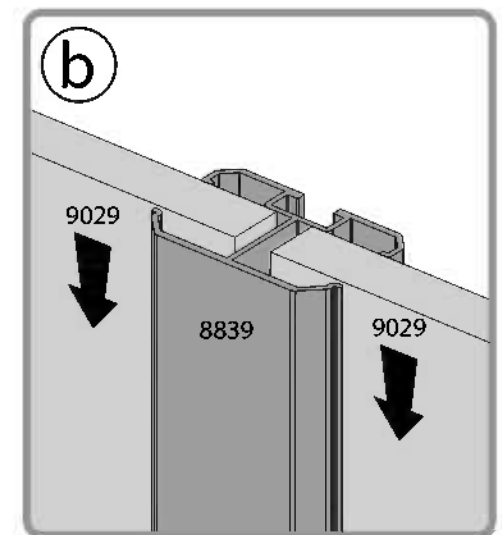
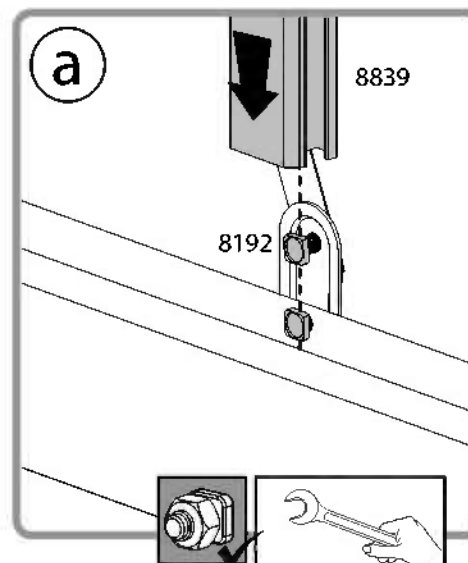
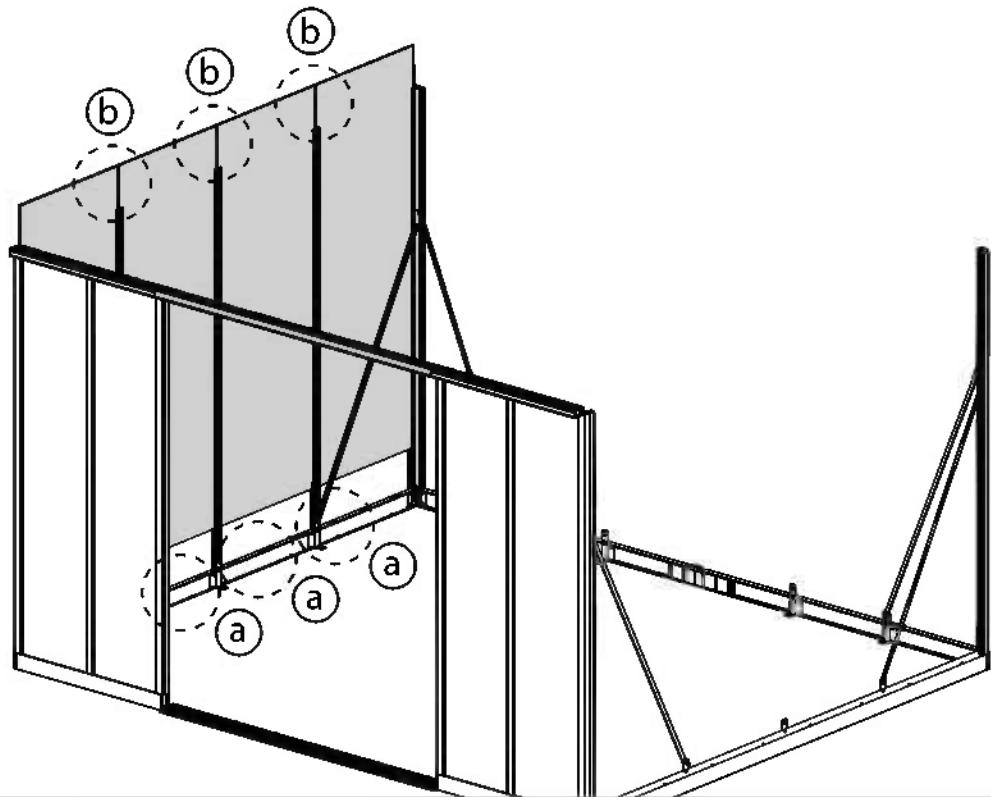
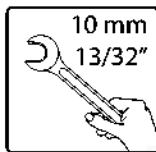
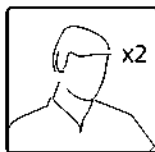

EN Matte side of the panel should face out

DE Die matte Seite aller Produktplatten sollte nach immer außen verlegt werden

FR Le côté mat de tous les panneaux du produit devrait être tourné vers l'extérieur

SP El lado mate de todos los paneles del producto debe estar mirando hacia afuera

23



It is recommended to insert screws #8192 as preparation for mounting shelves. If you've purchased a shelf kit, mount a maximum of 2 shelves per post.

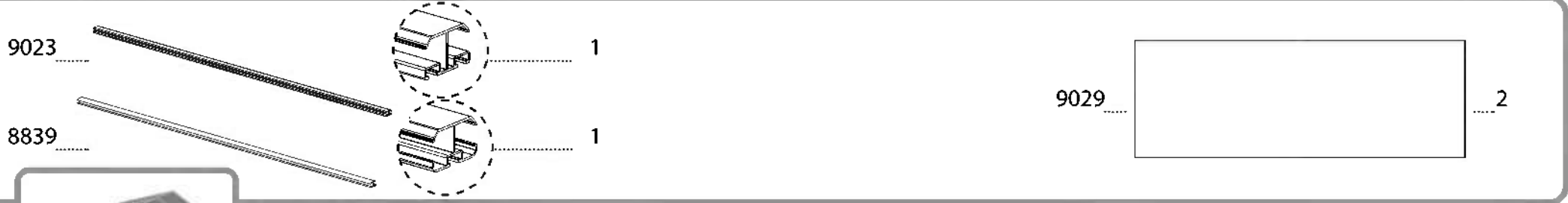

11'x13'
11'x9' + 11'x4'

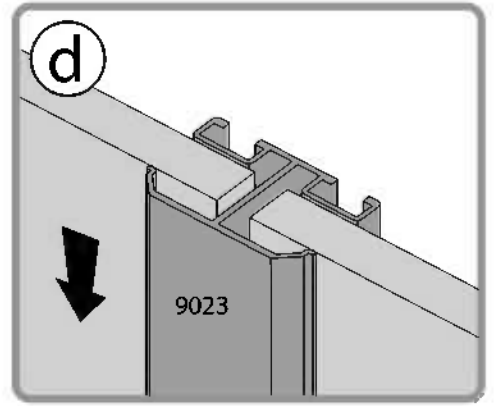
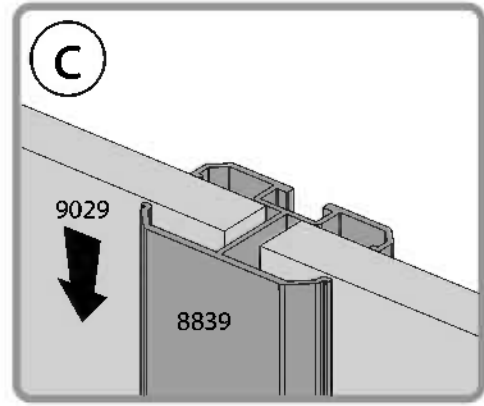
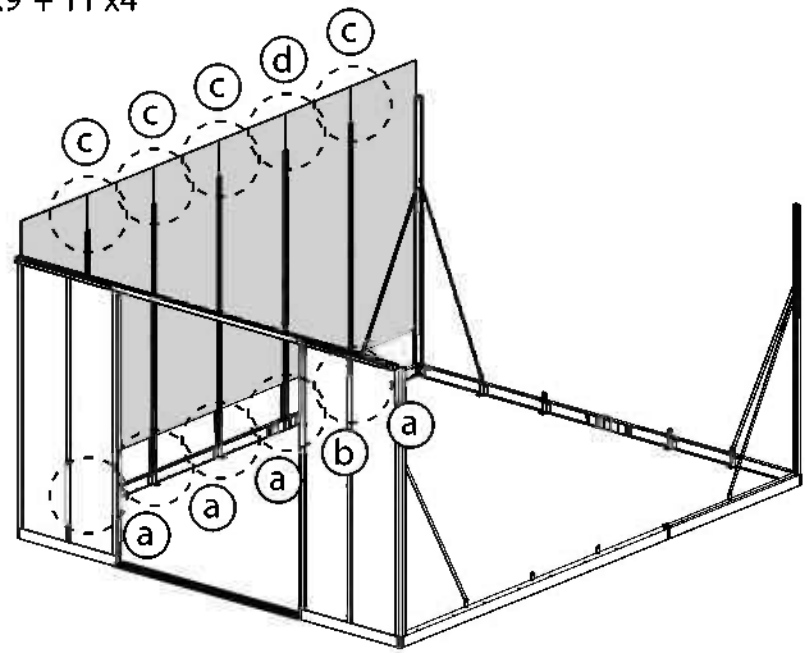
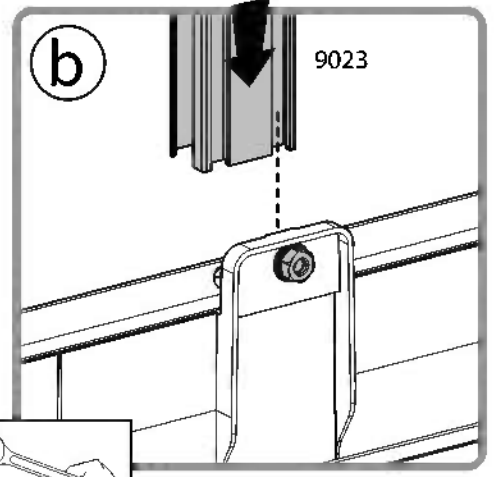
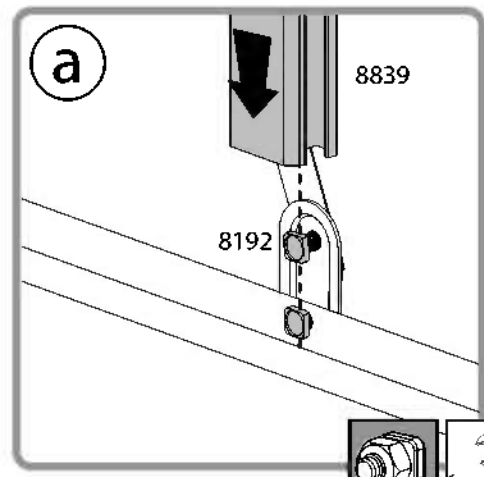
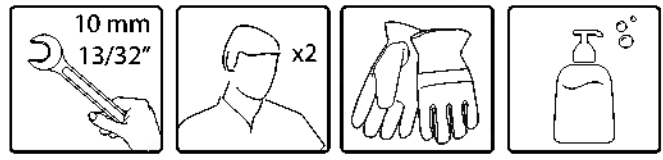



411 2
466 2

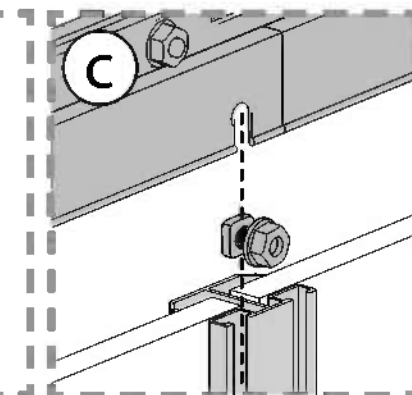
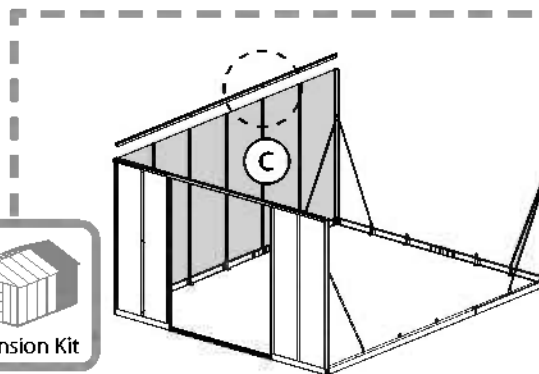
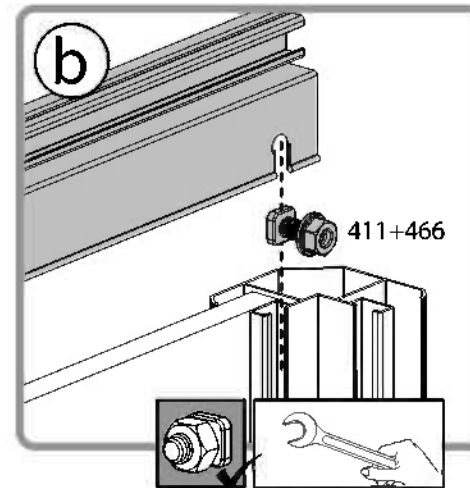
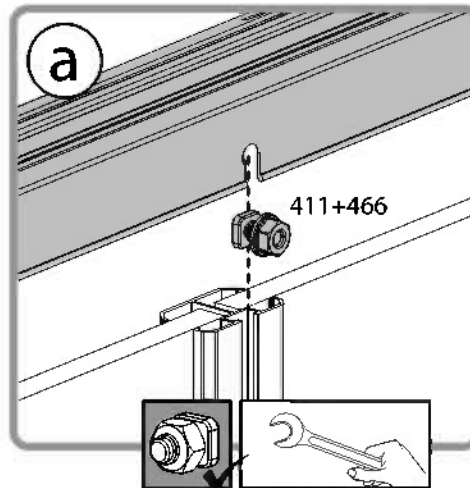
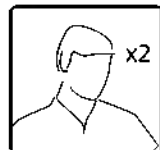
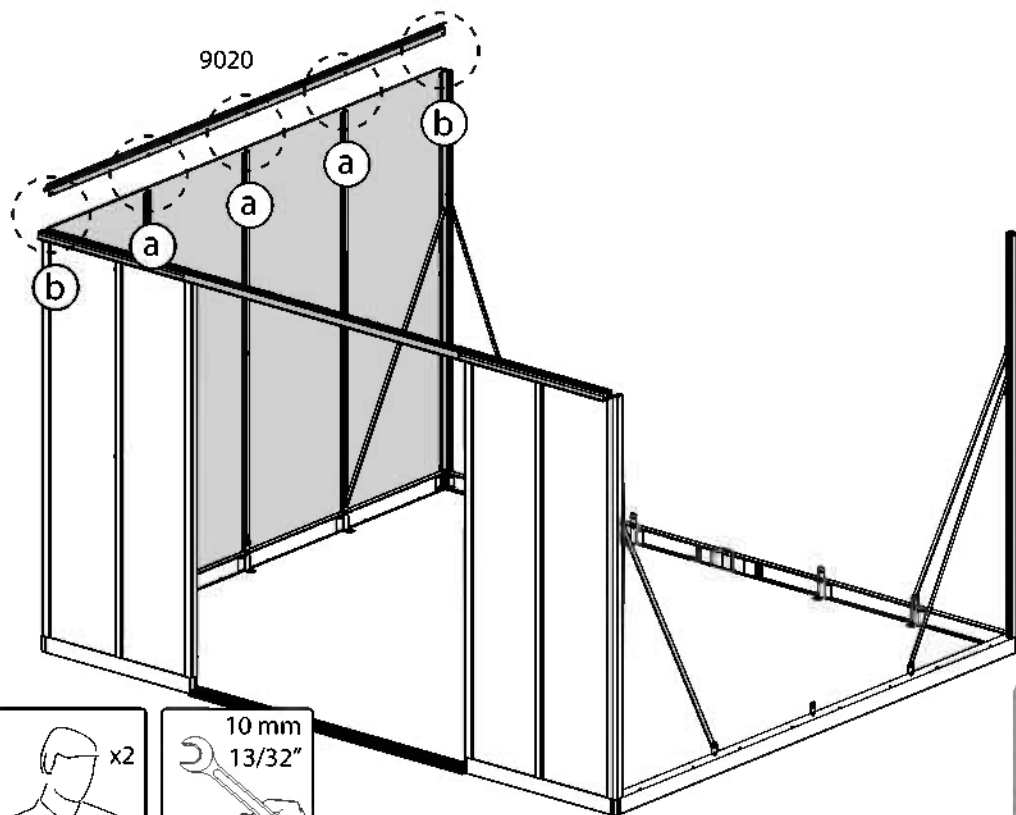

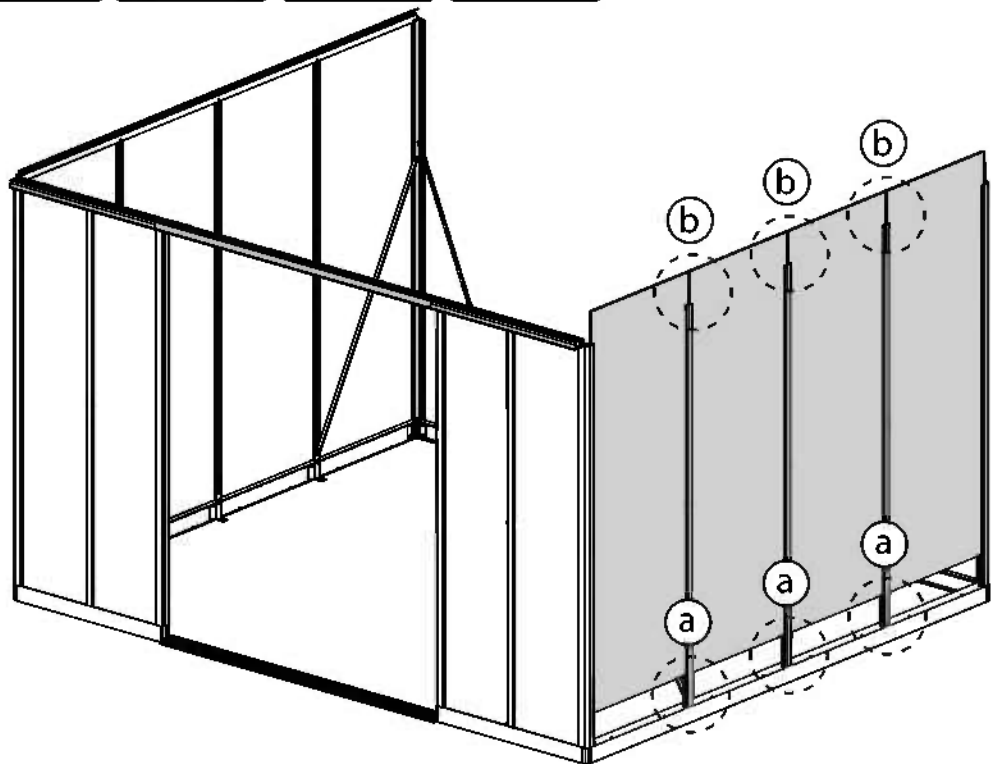
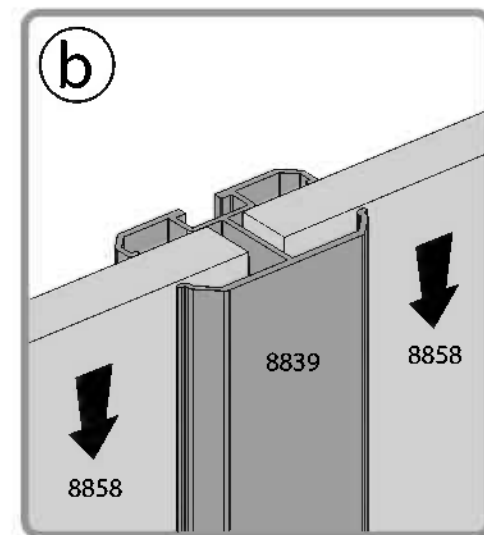
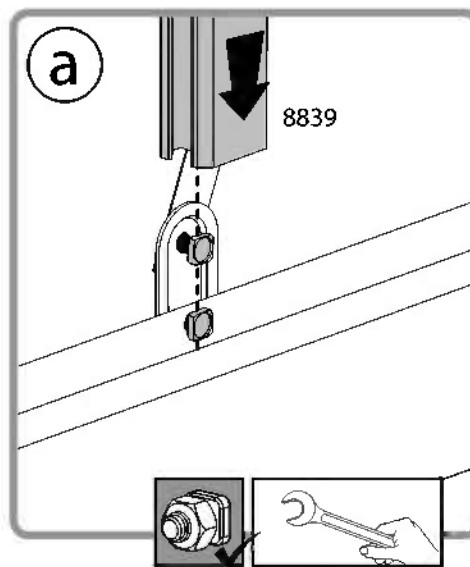
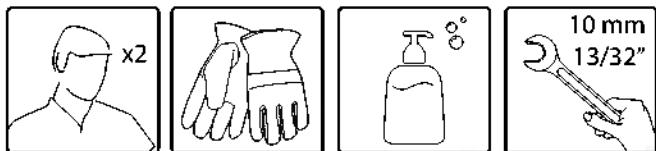
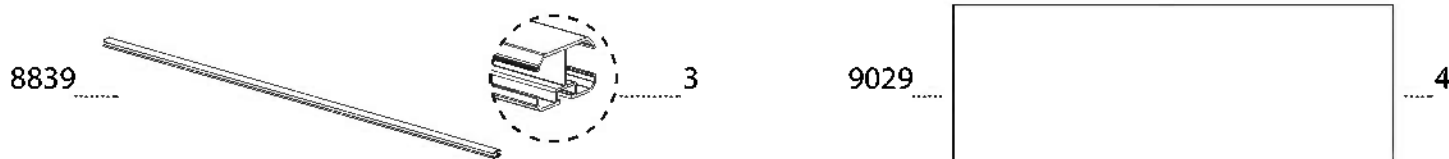

EN Matte side of the panel should face out
DE Die matte Seite aller Produktplatten sollte nach immer außen verlegt werden
FR Le côté mat de tous les panneaux du produit devrait être tourné vers l'extérieur
SP El lado mate de todos los paneles del producto debe estar mirando hacia afuera

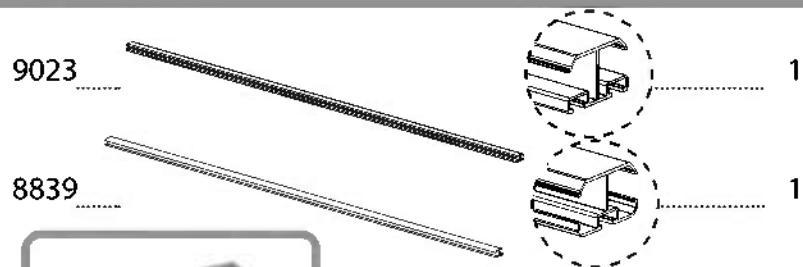

11'x13'
11'x9' + 11'x4'

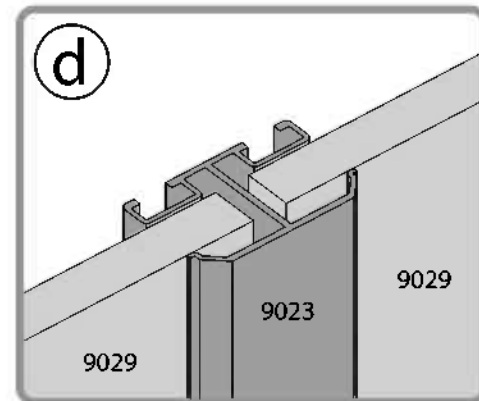
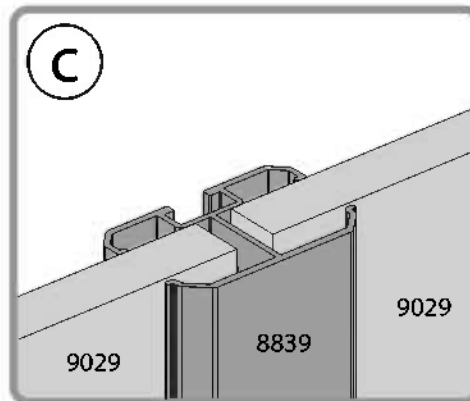
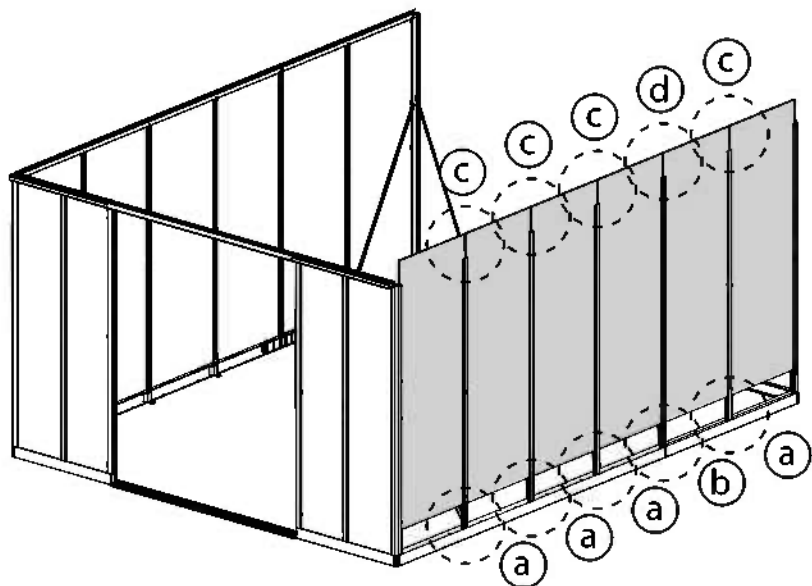
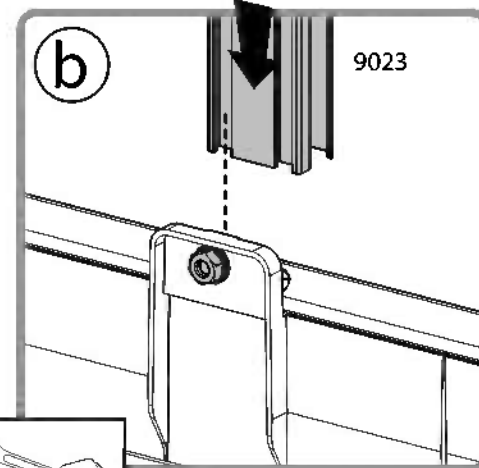
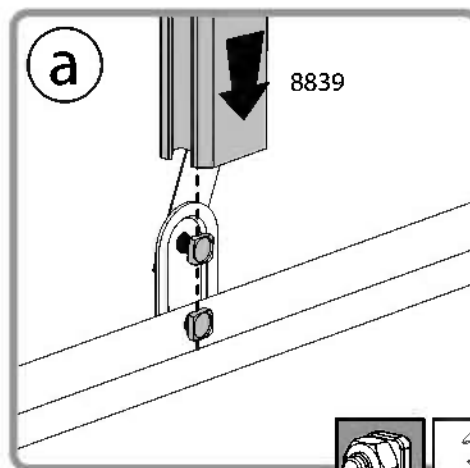
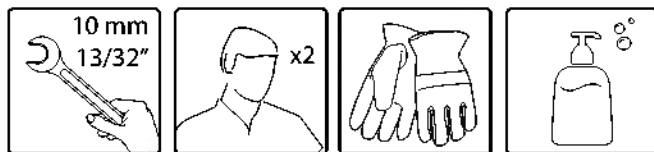

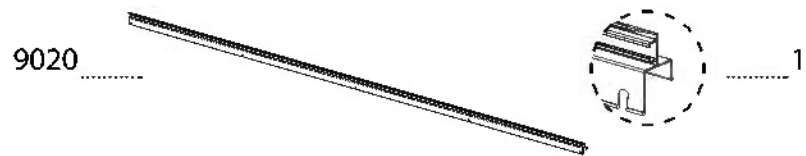

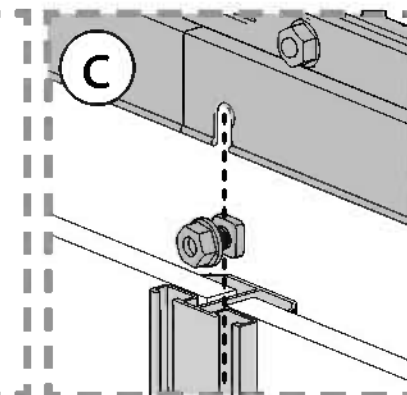
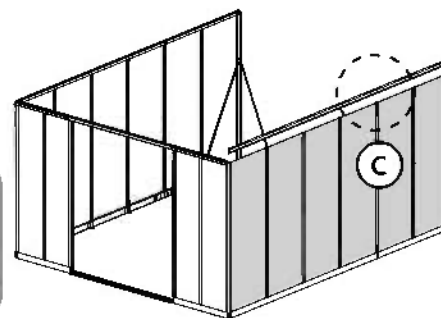
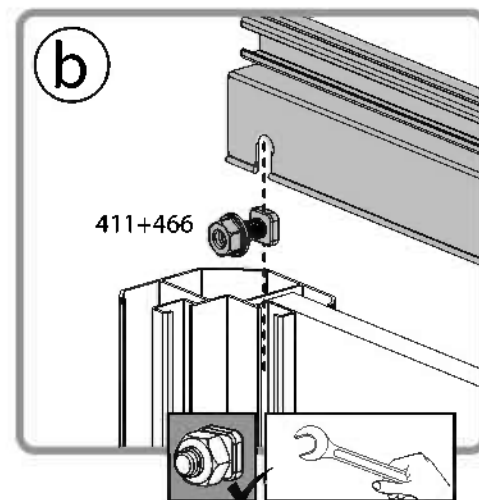
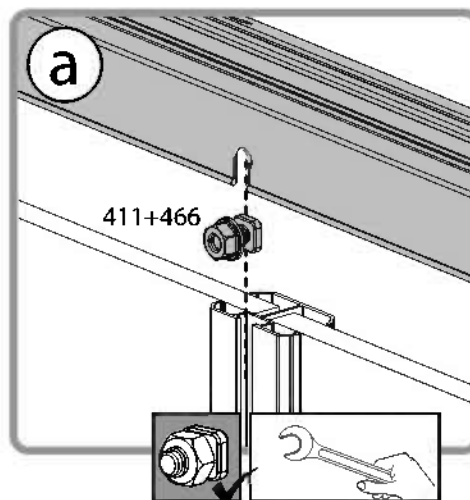
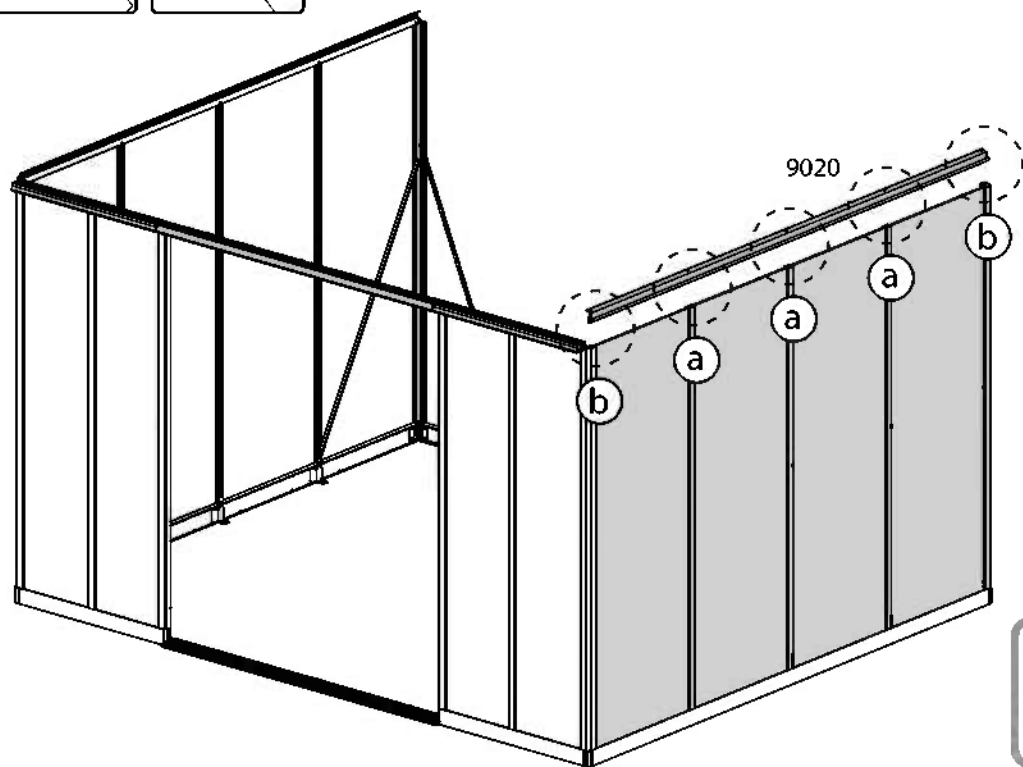

411 2
466 2

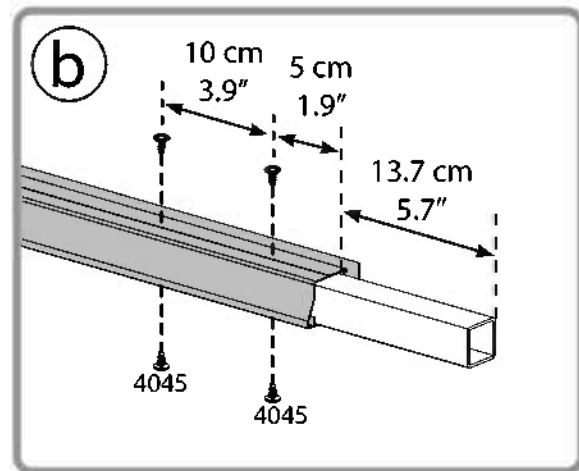
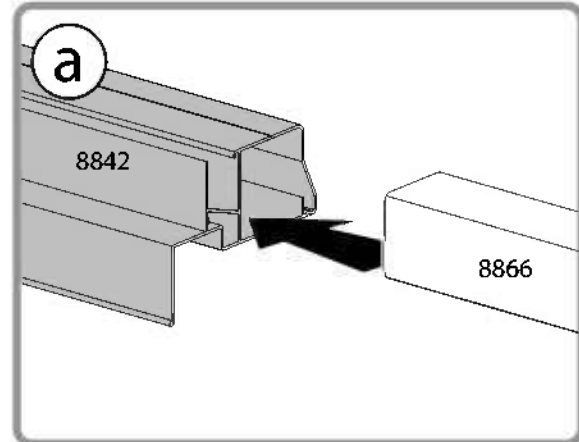
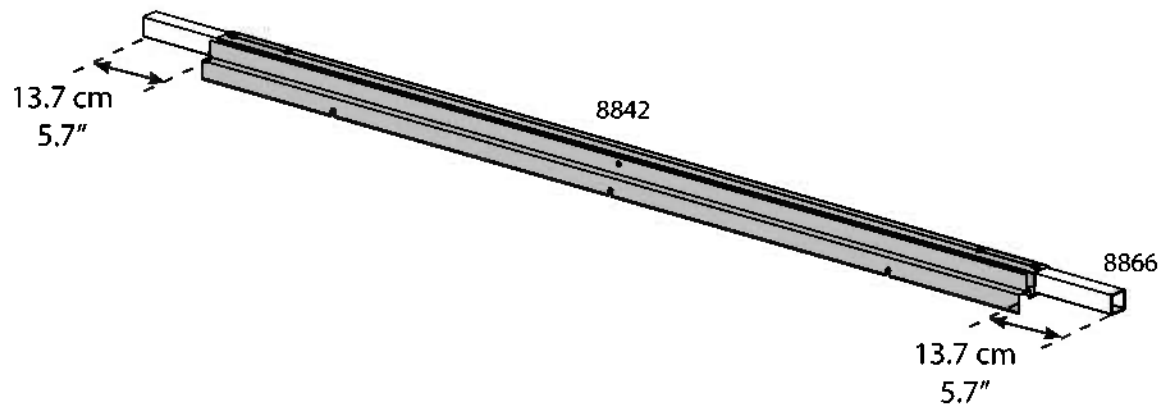
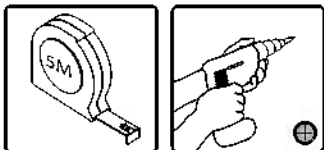
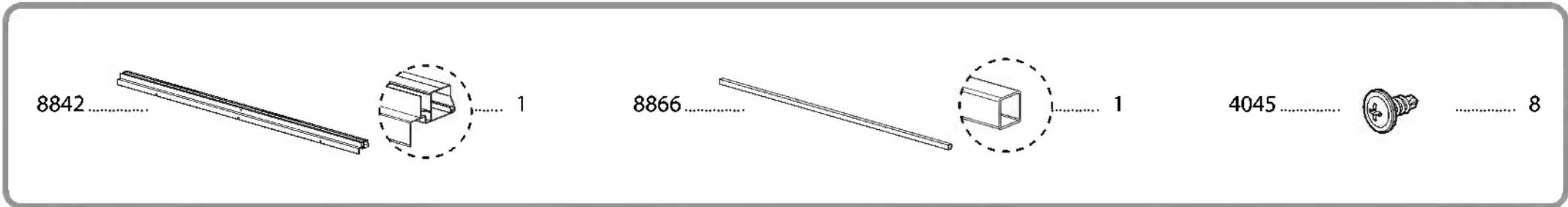



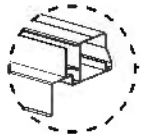

8845   2

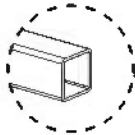
8867   2

4045  12

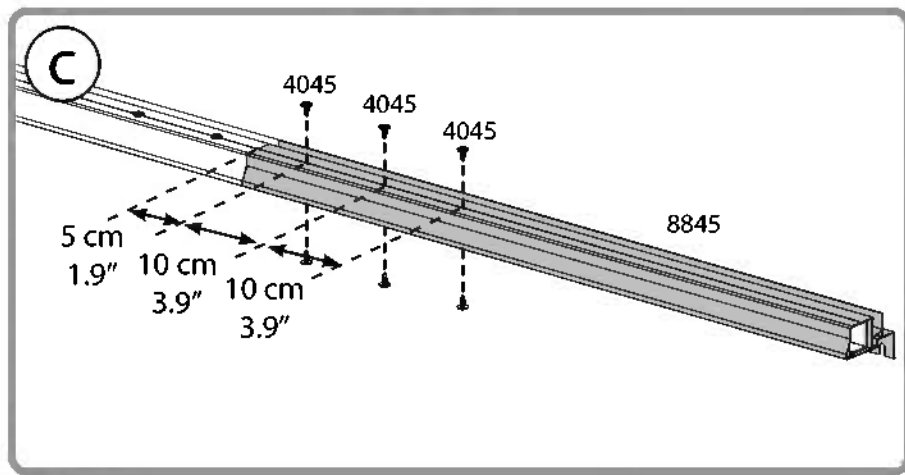
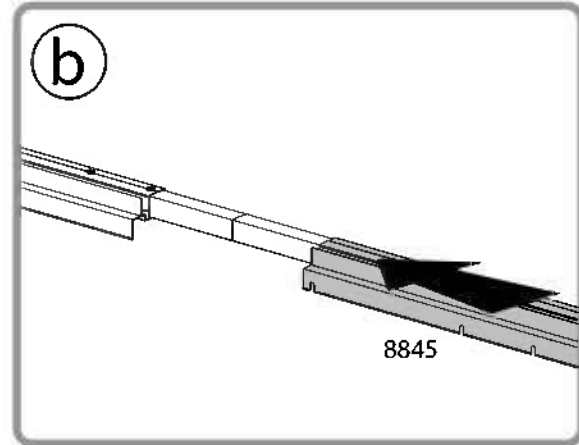
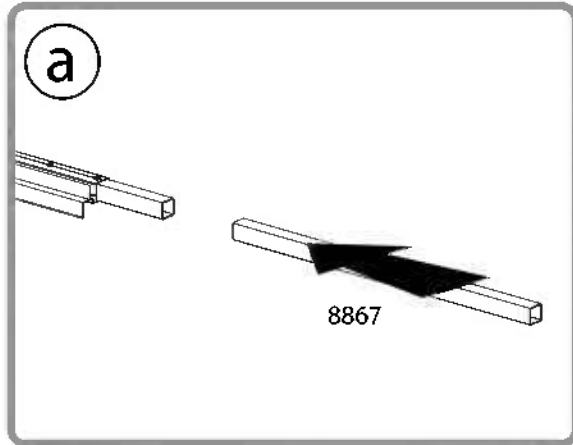
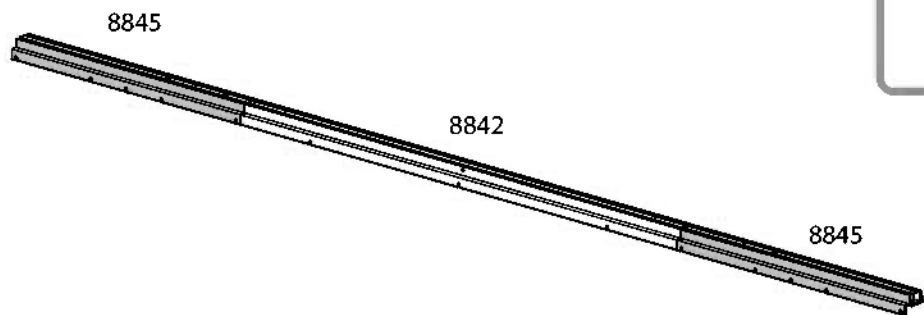
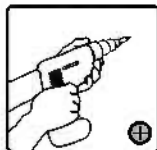

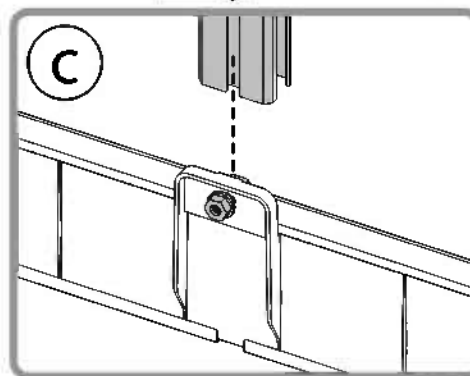
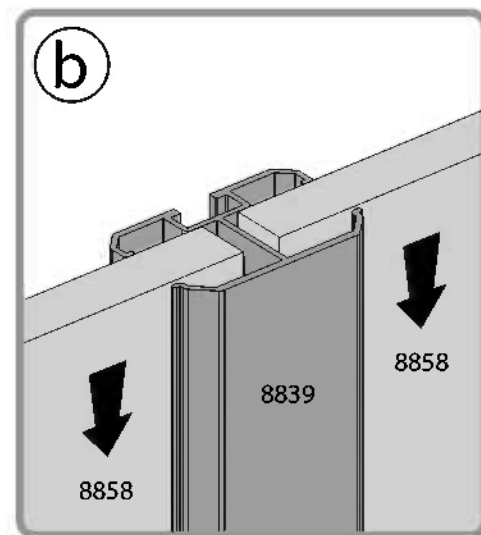
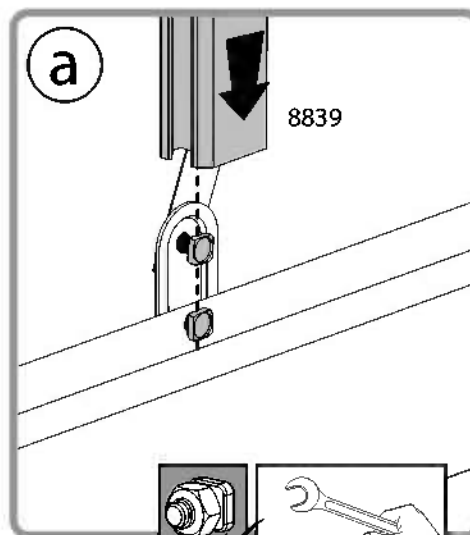
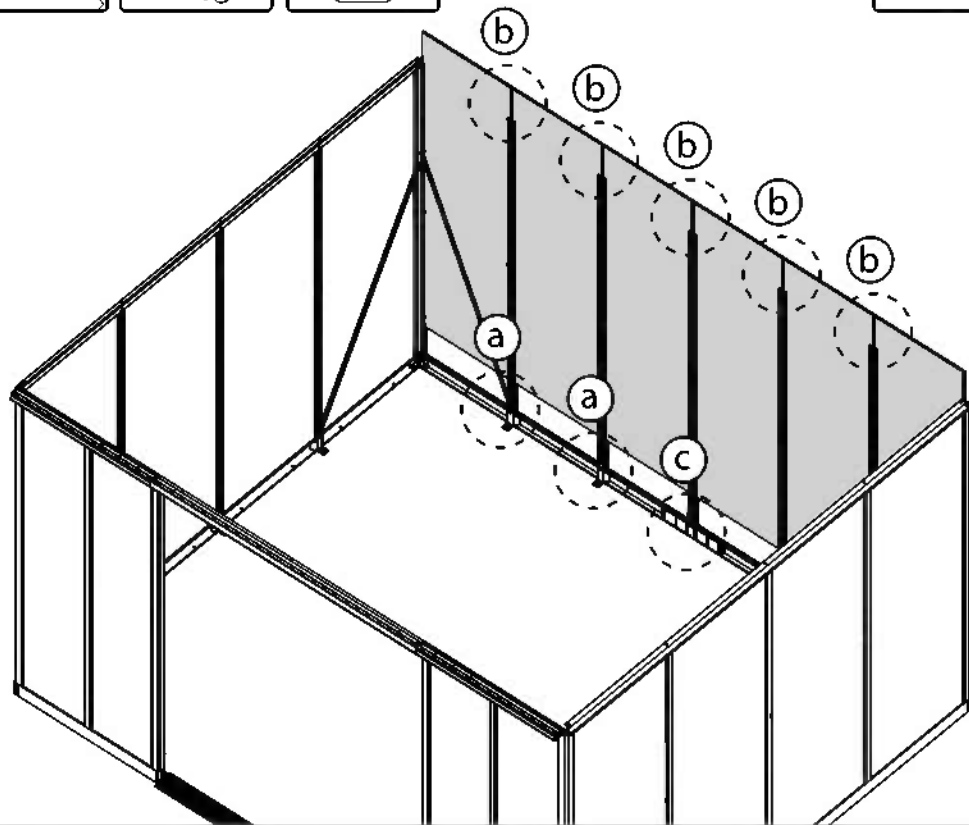
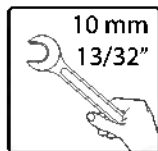
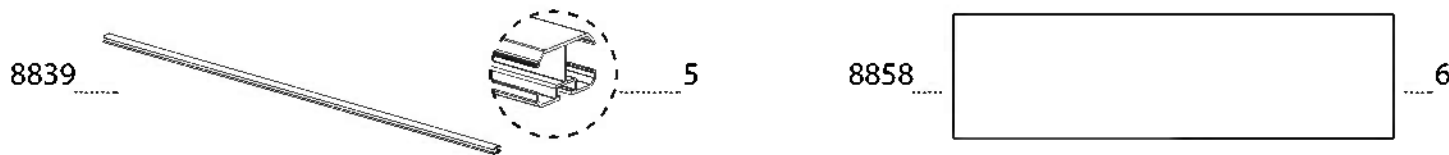

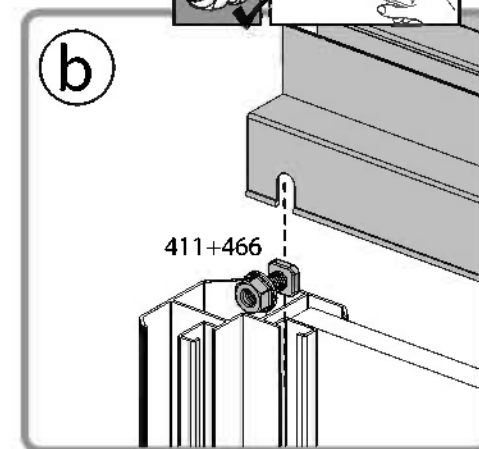
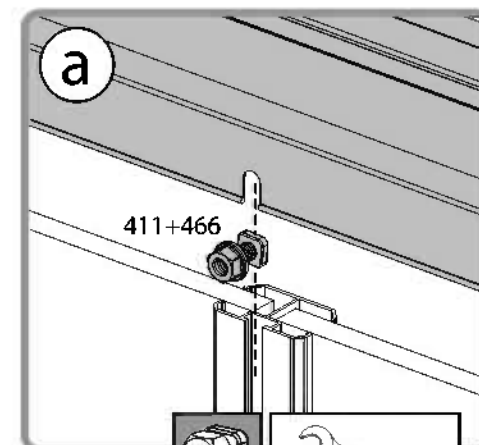
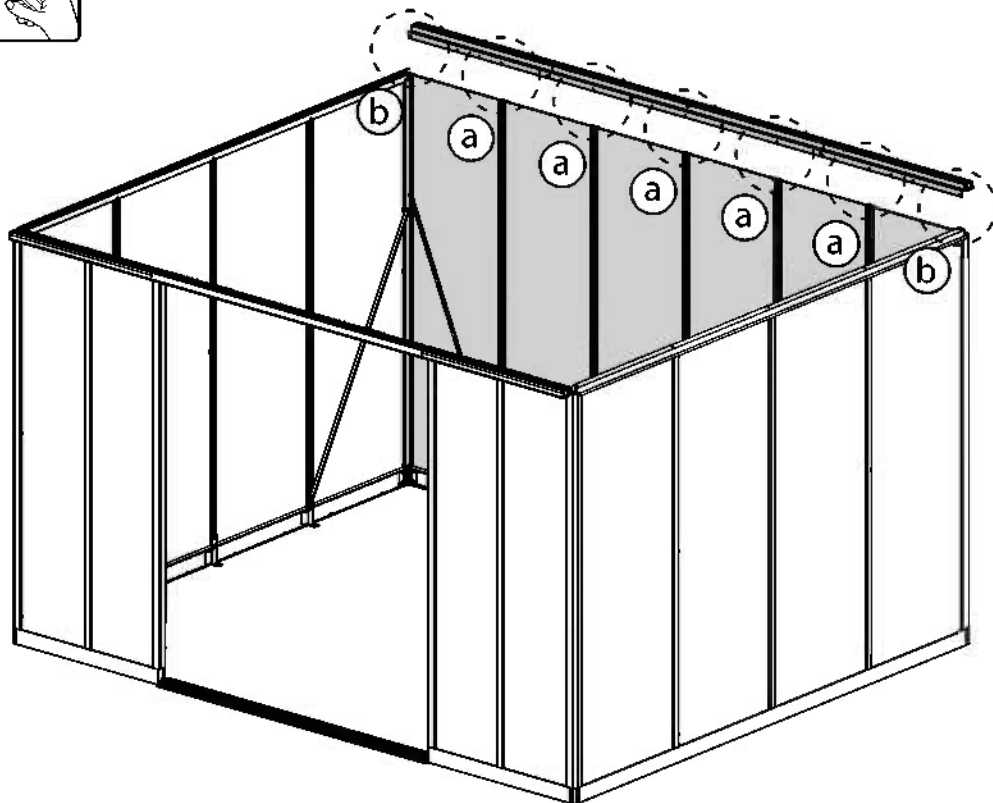
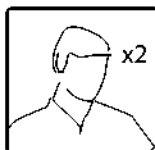
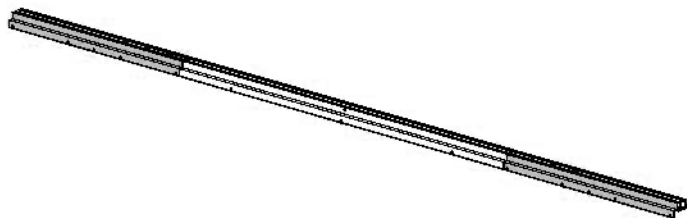

32



Before inserting the screws, make sure the internal metal profiles are not protruding.

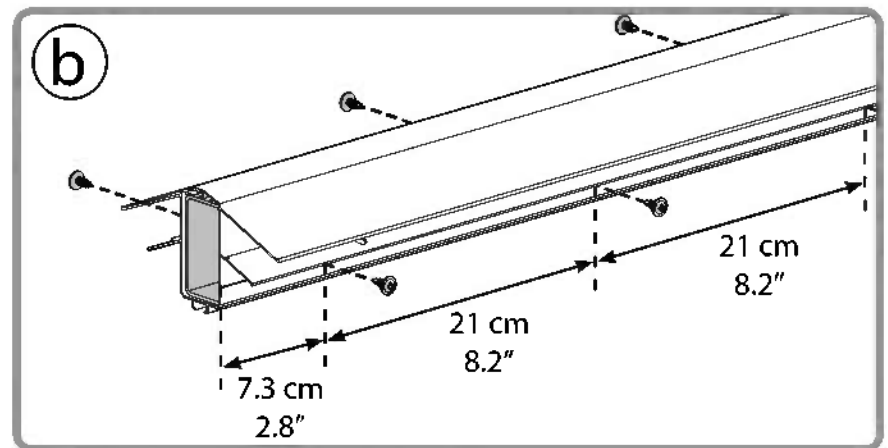
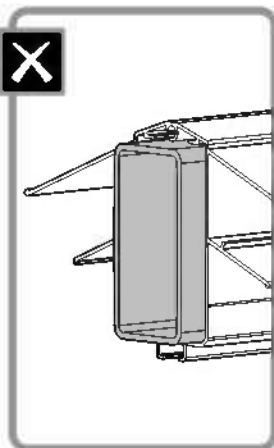
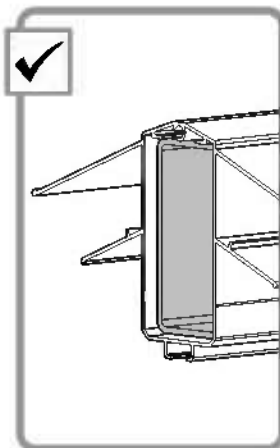
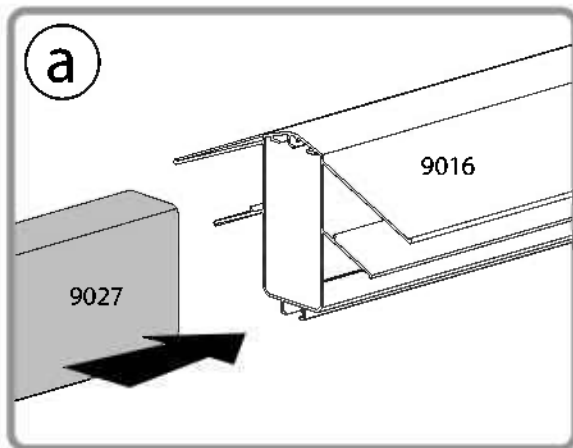
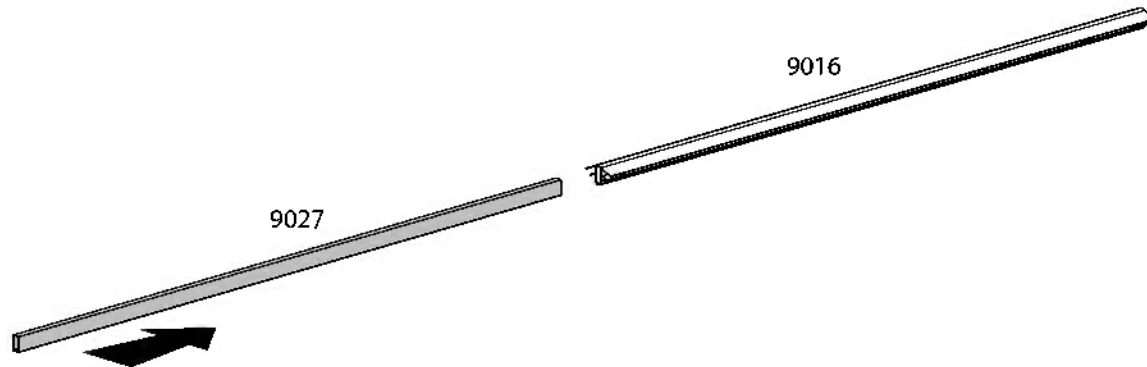
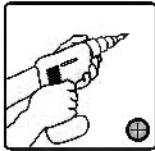
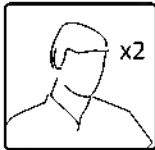
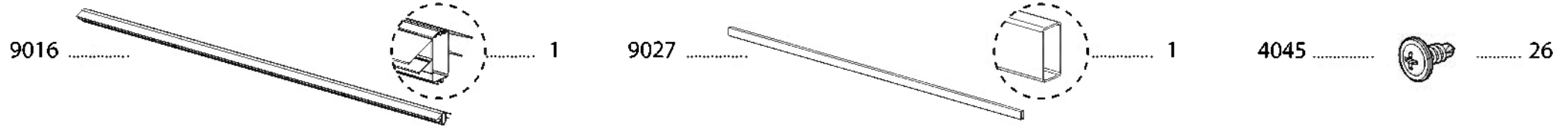

33 **i** Before inserting the screws, make sure the internal metal profiles are not protruding and are well connected with one another inside the aluminum profiles.

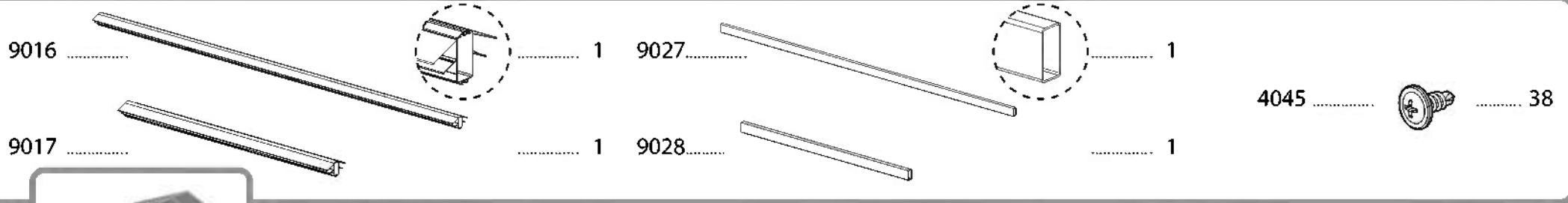

11'x13'
11'x9' + 11'x4'

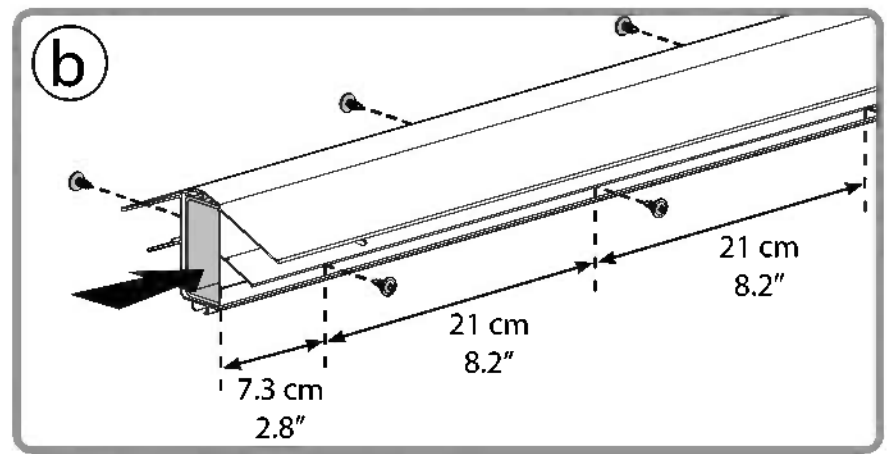
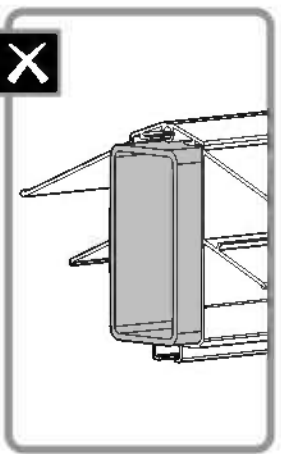
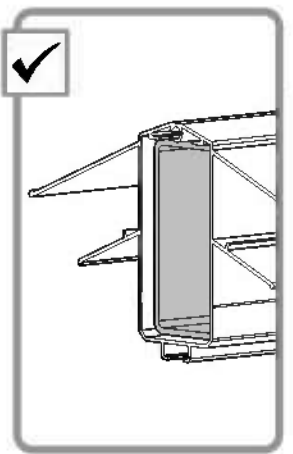
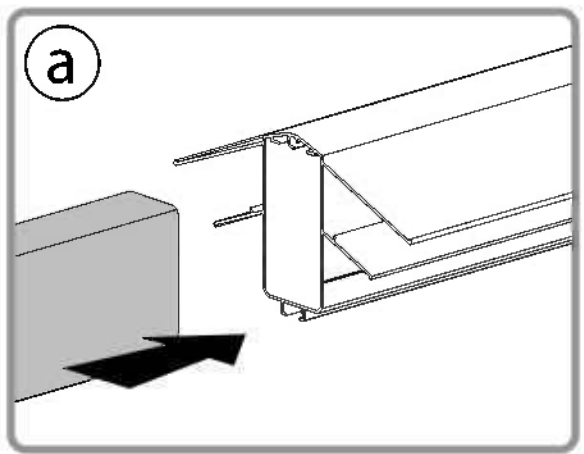
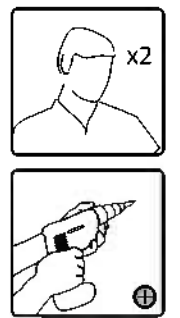
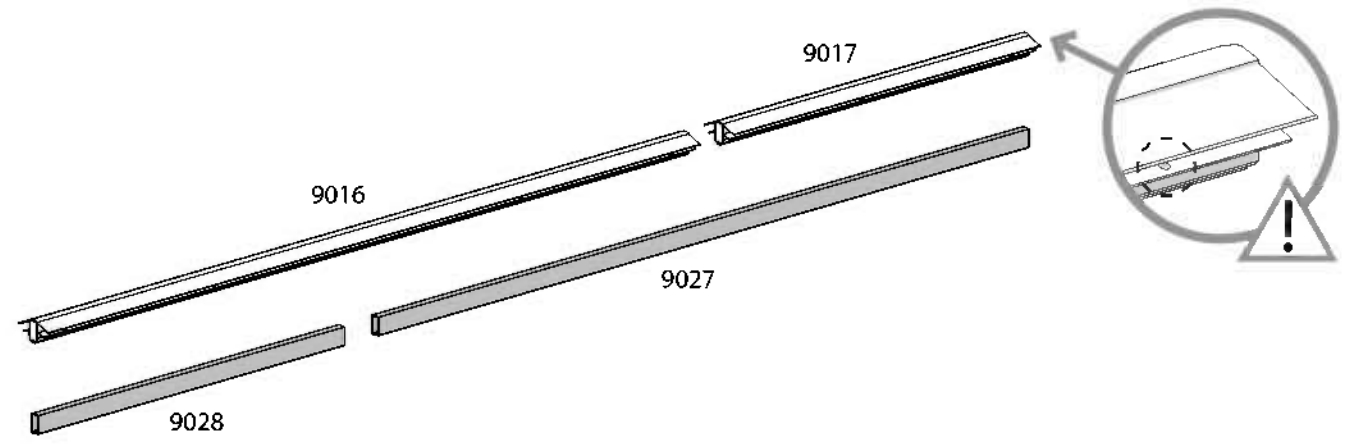



411 10



466 10



411 4

466 4

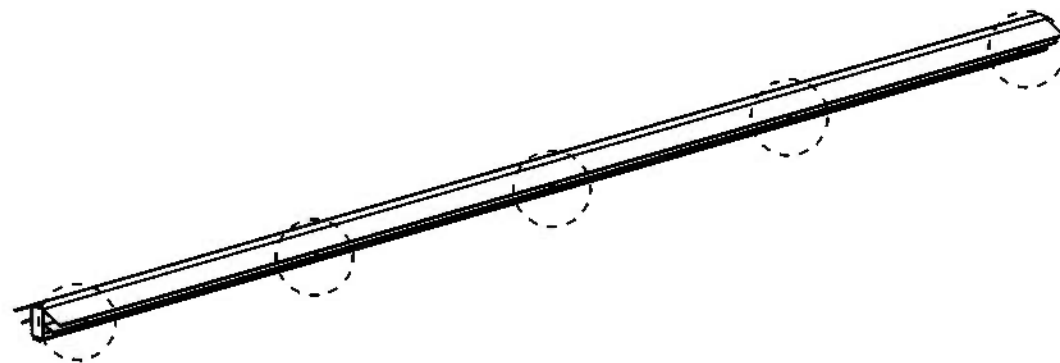
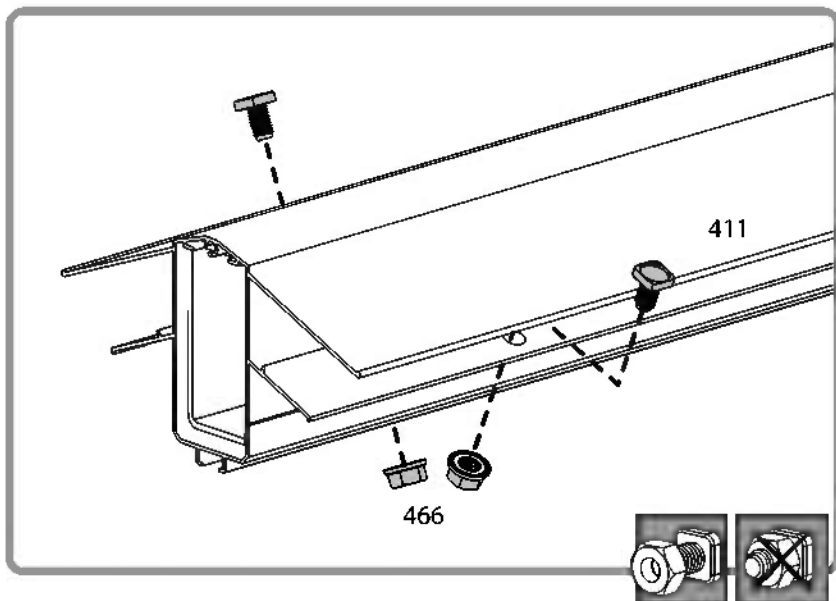



- 7985 1
- 411 4
- 466 4



Extension Kit

11'x13'
11'x9' + 11'x4'

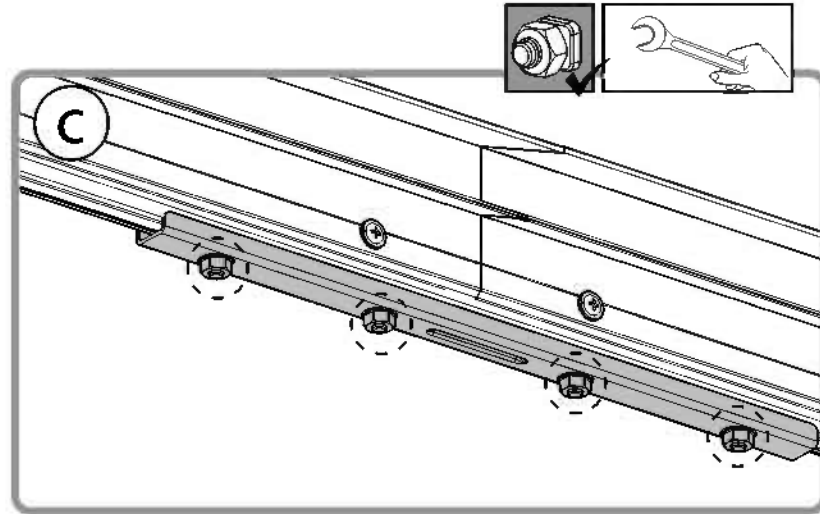
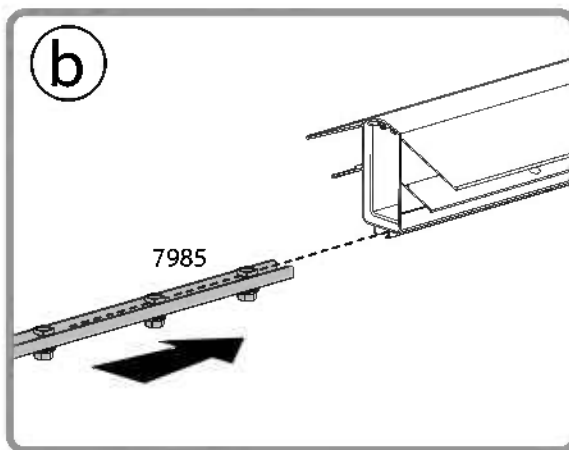
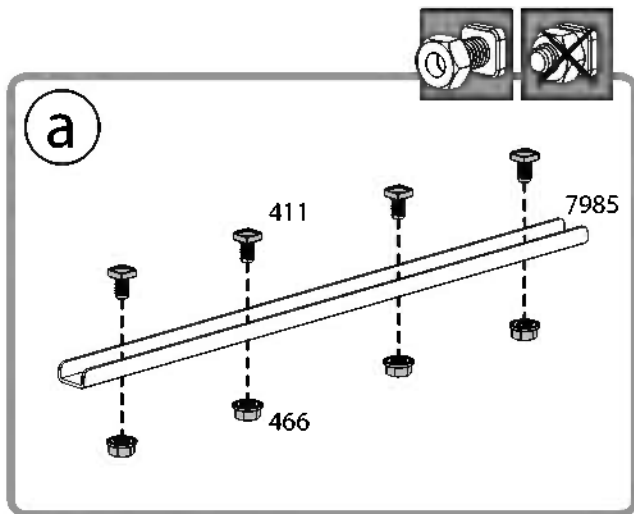
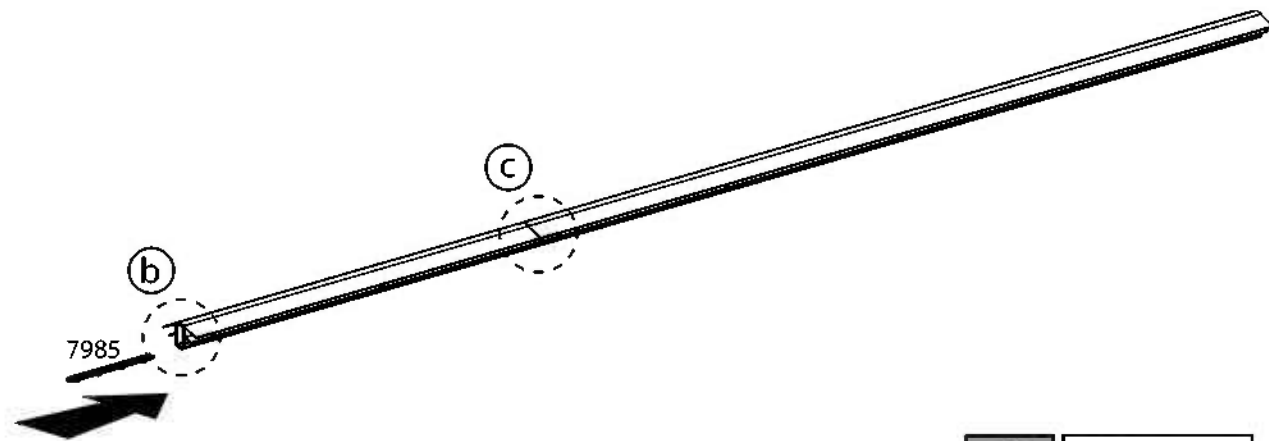
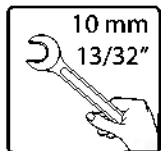



The sticker must be placed on a clean and dry surface



100..... 2



Extension Kit

11'x13'
11'x9' + 11'x4'

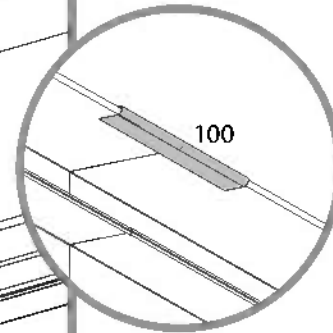
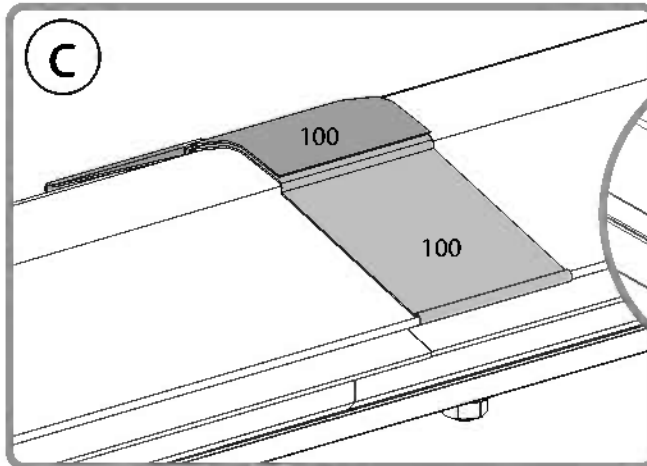
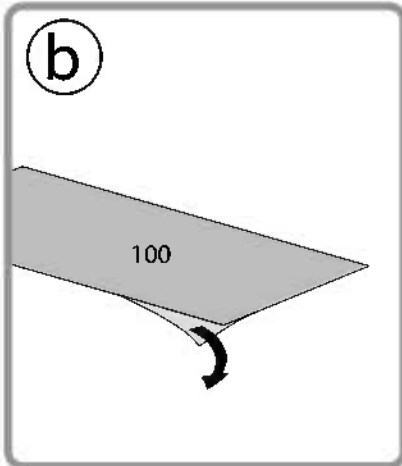
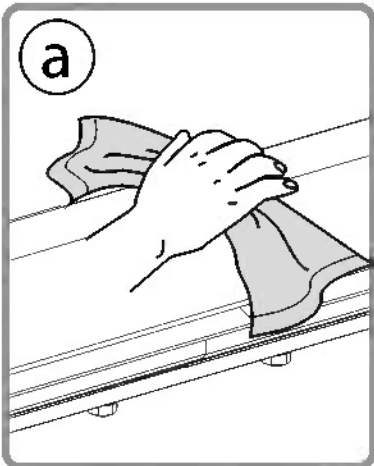
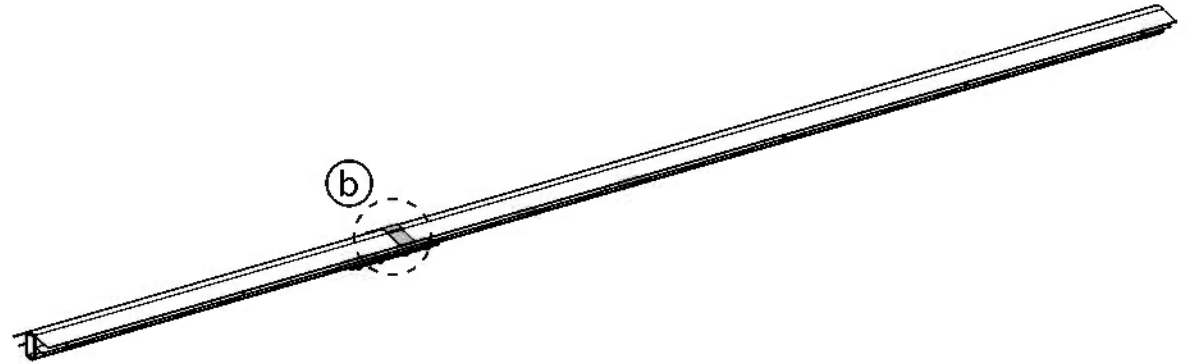

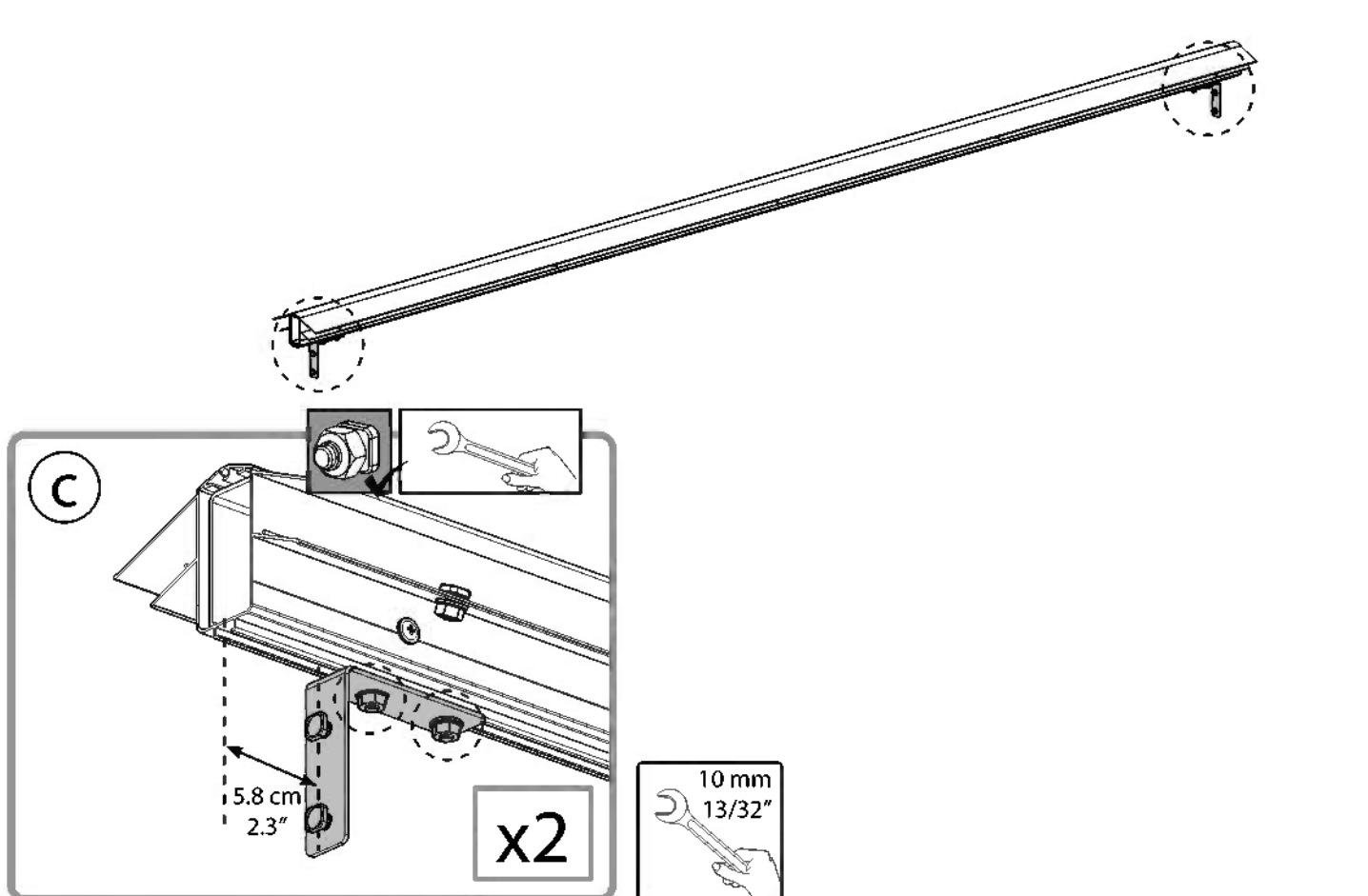
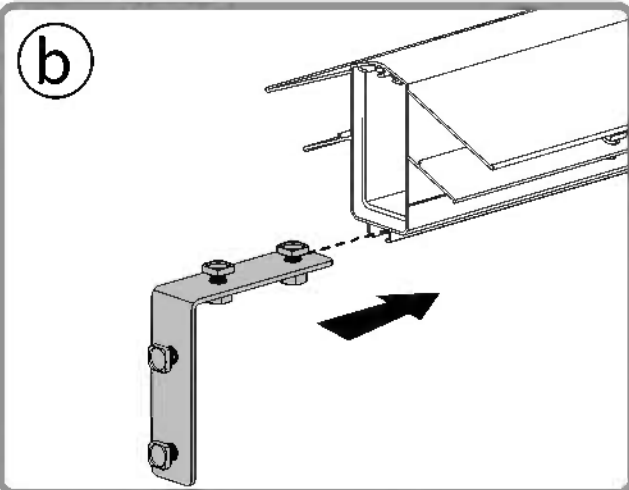
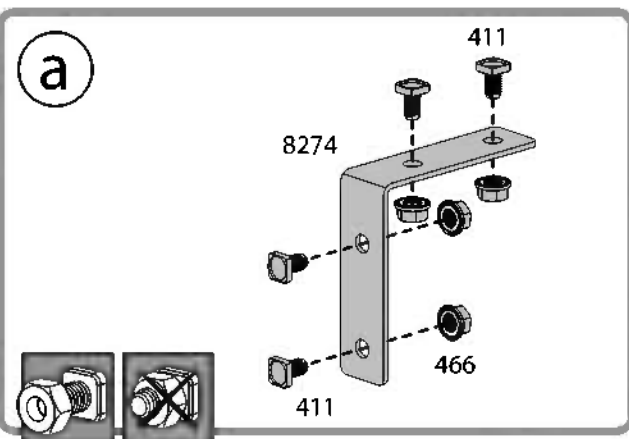
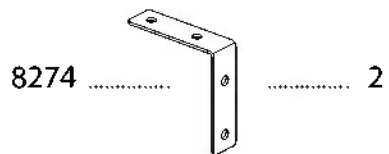

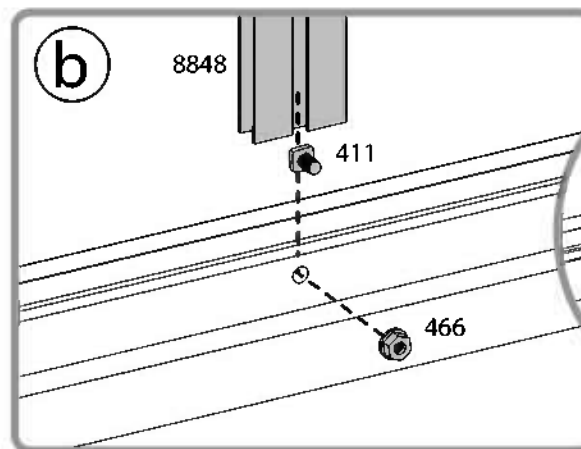
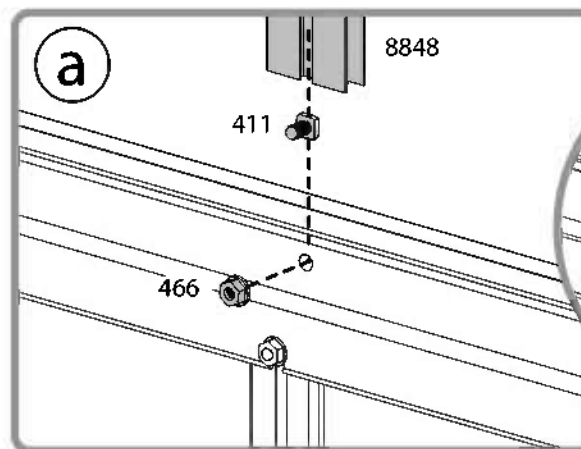
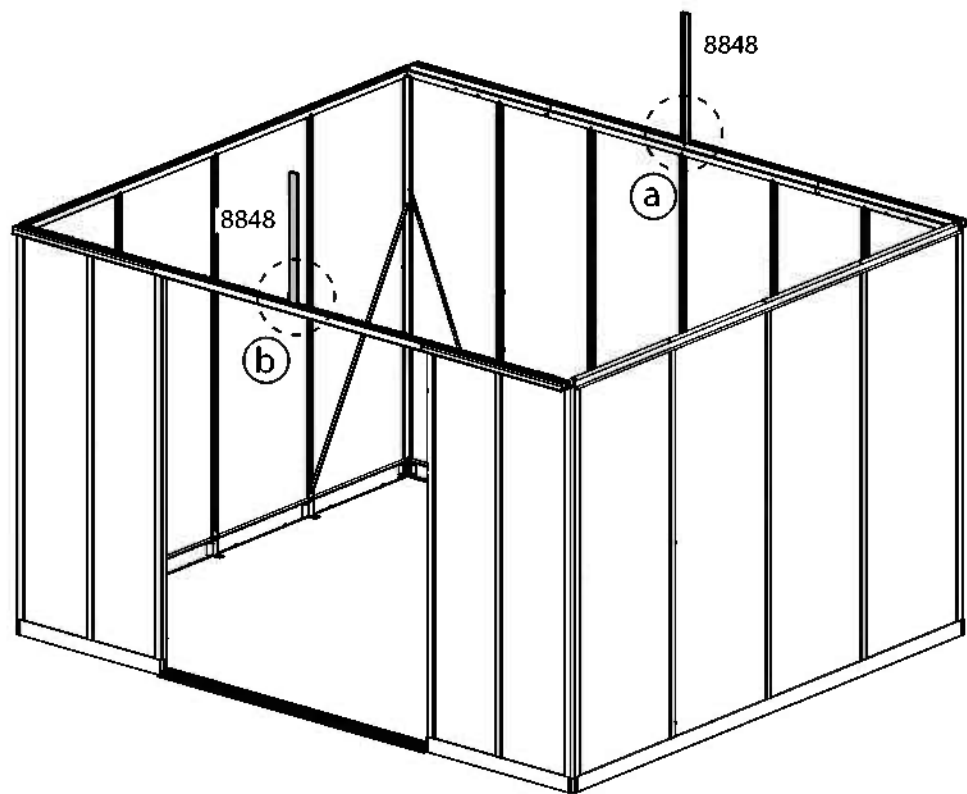
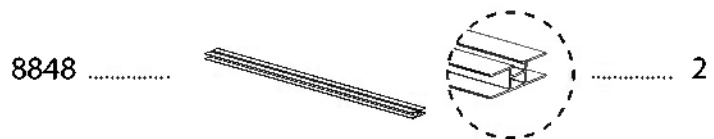



411 10



466 10



411 4

466 4

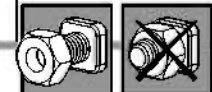
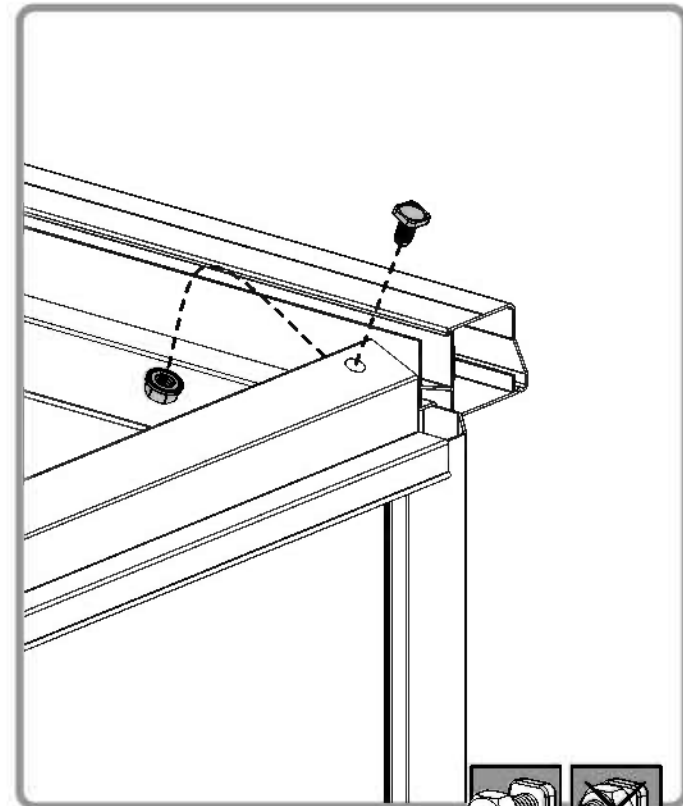
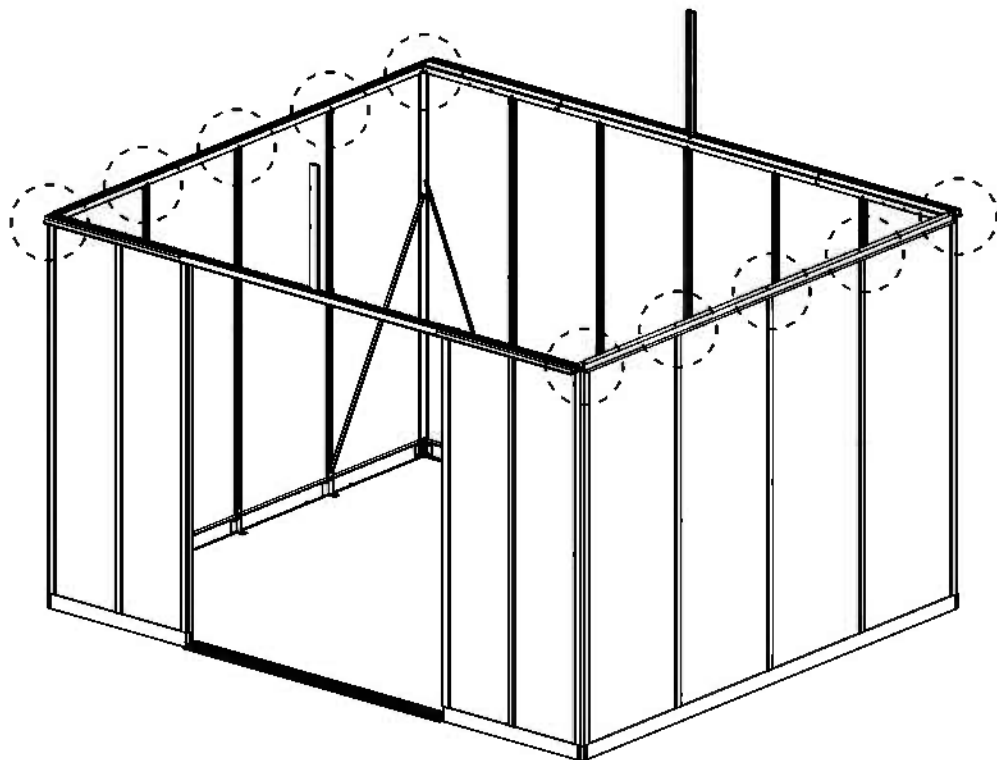

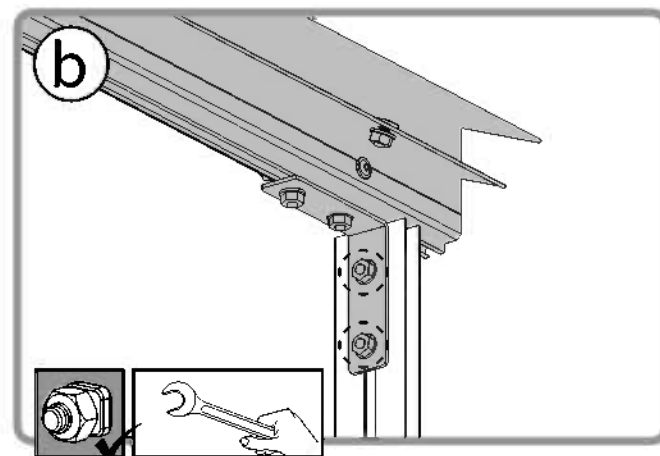
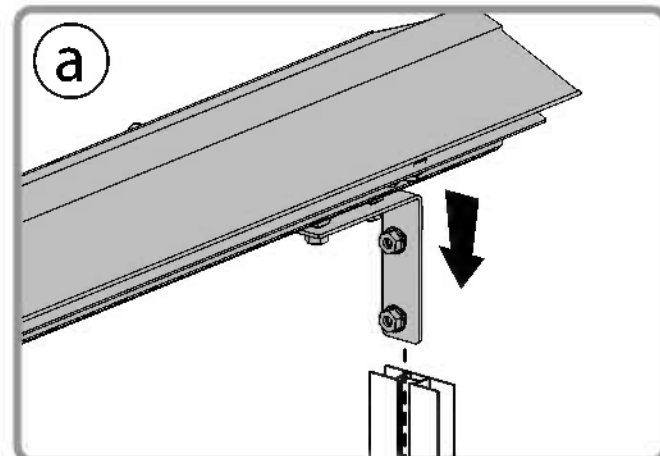
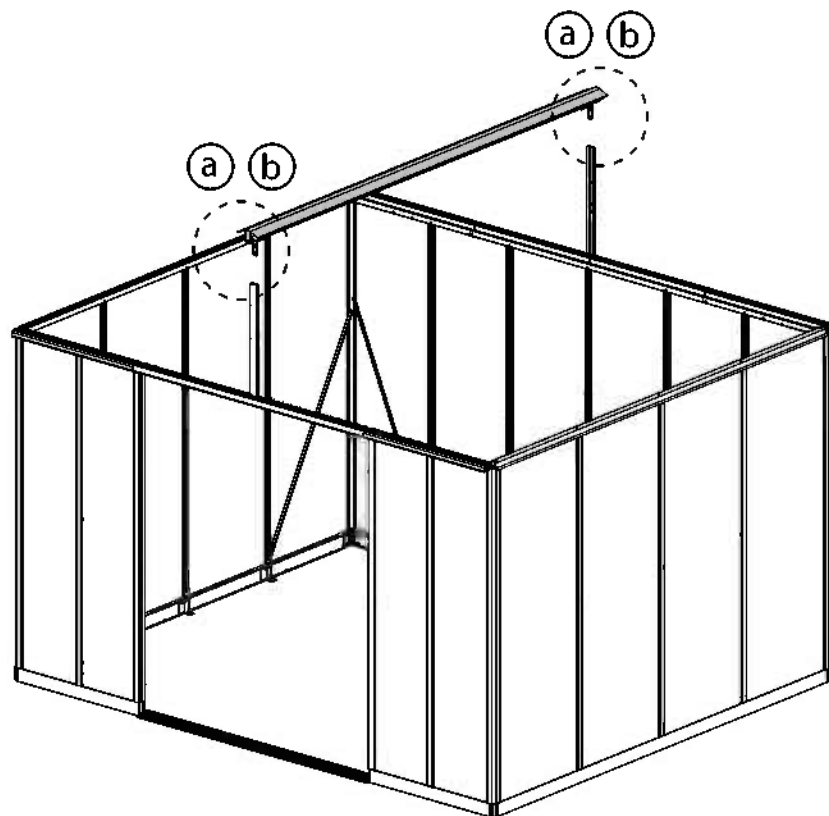
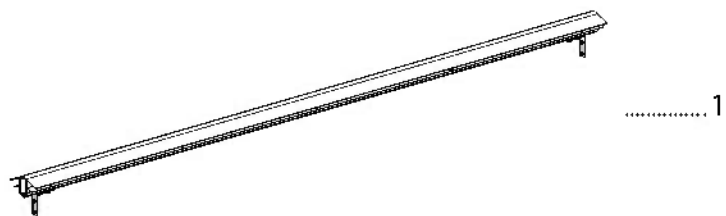

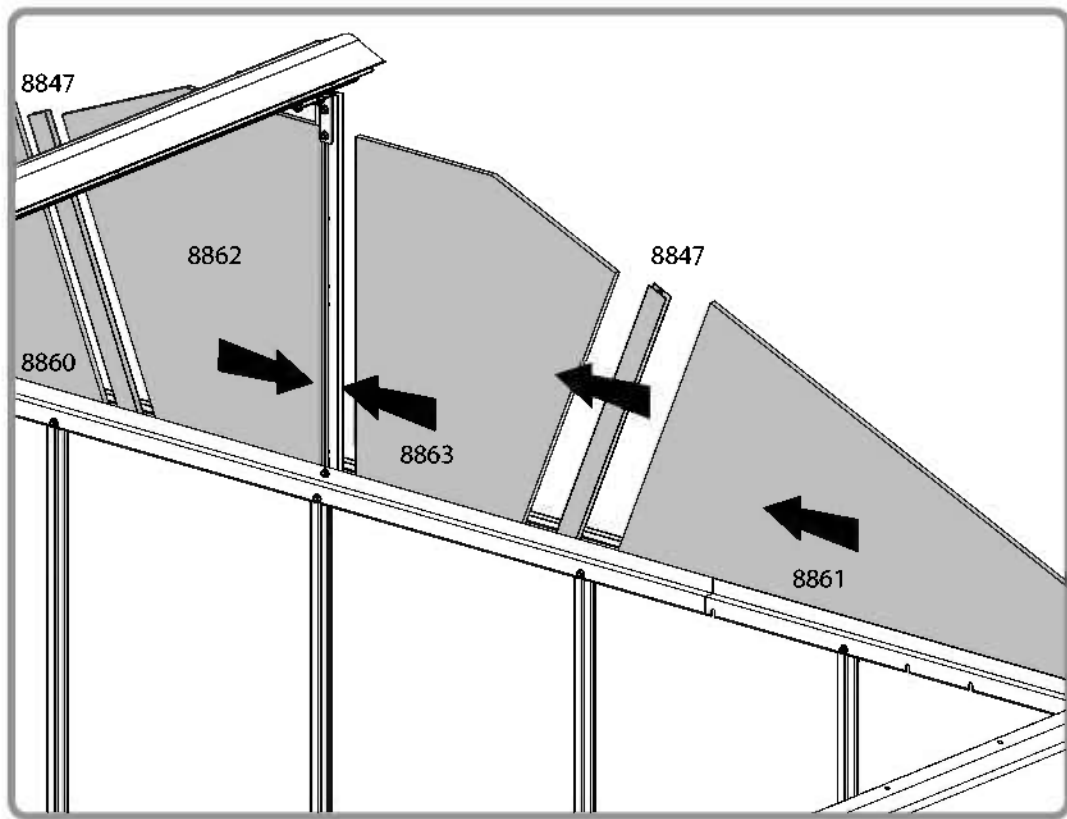
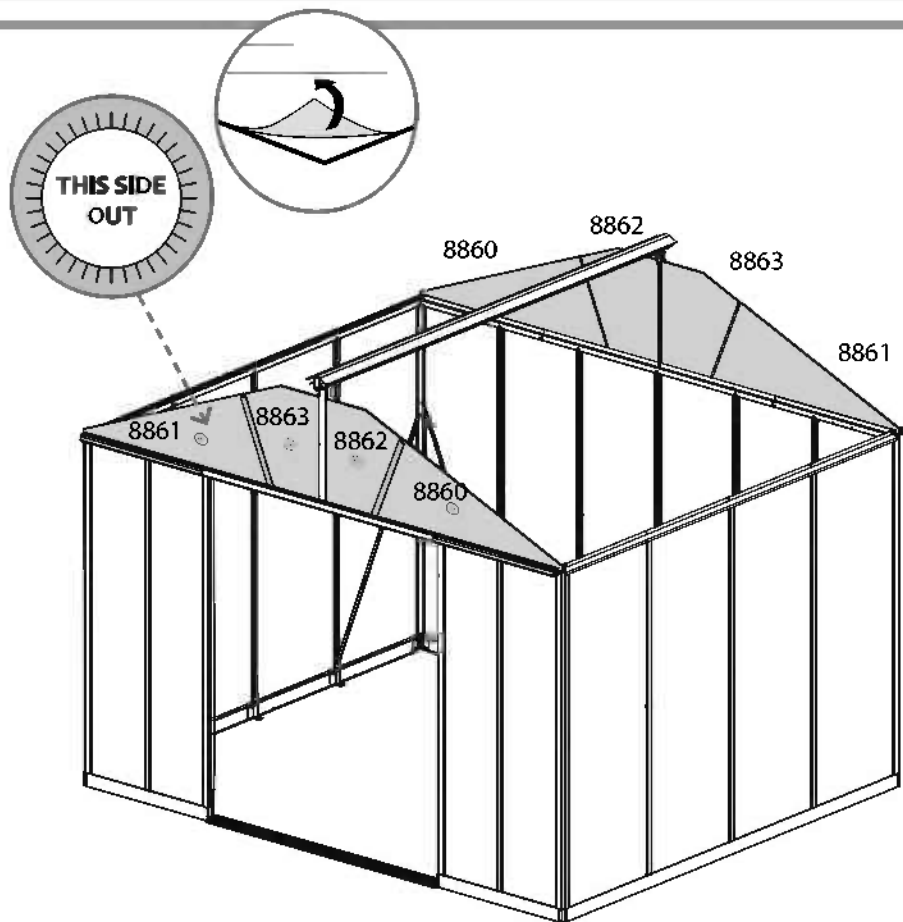
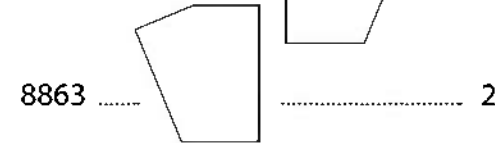
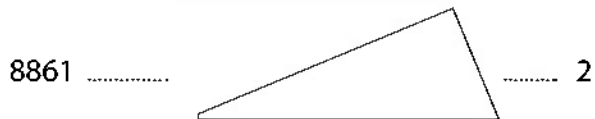
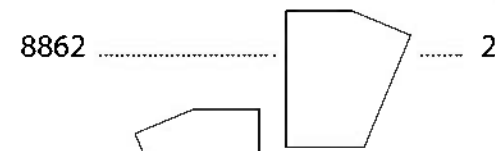
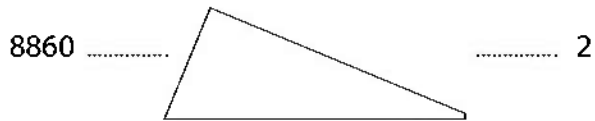
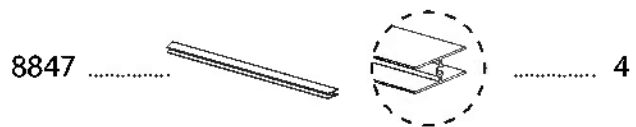



8846

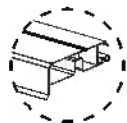
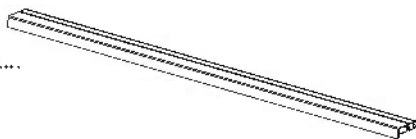

4

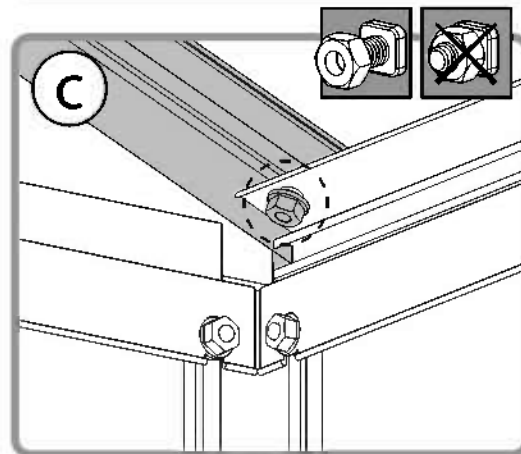
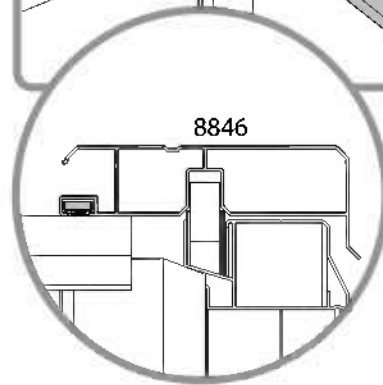
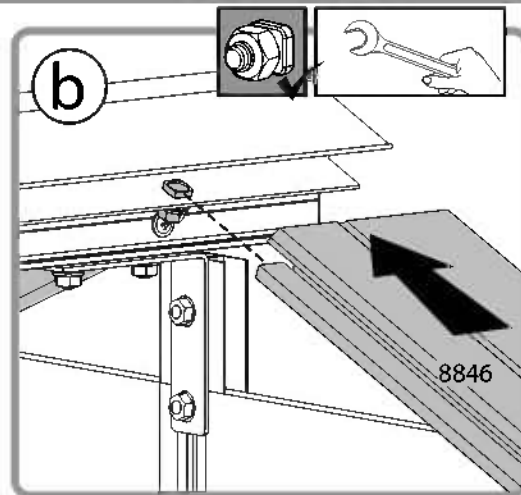
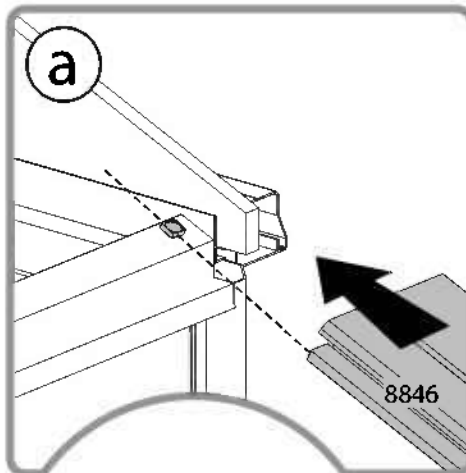
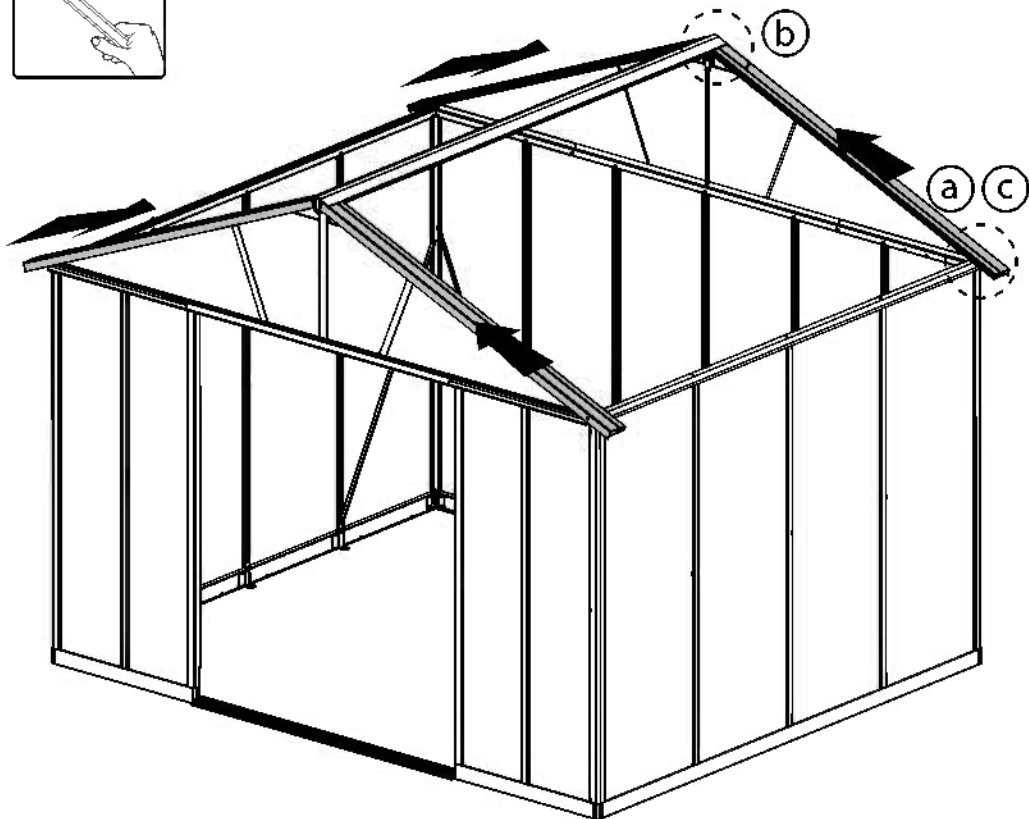

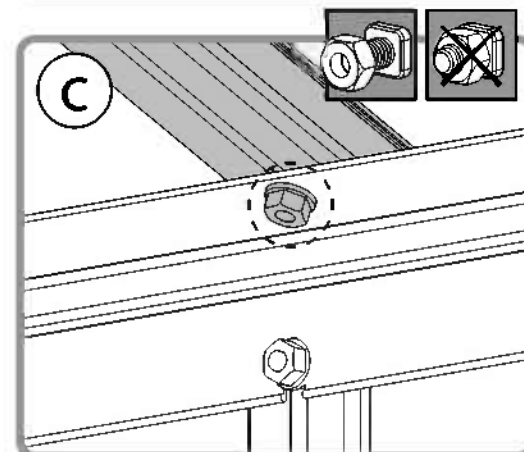
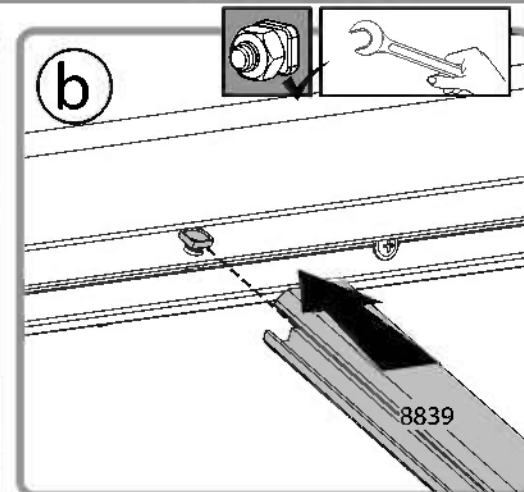
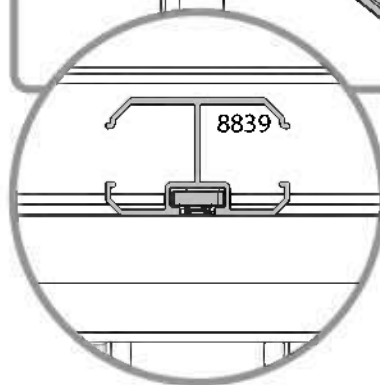
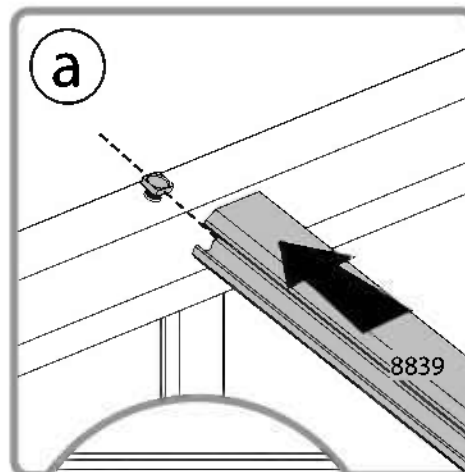
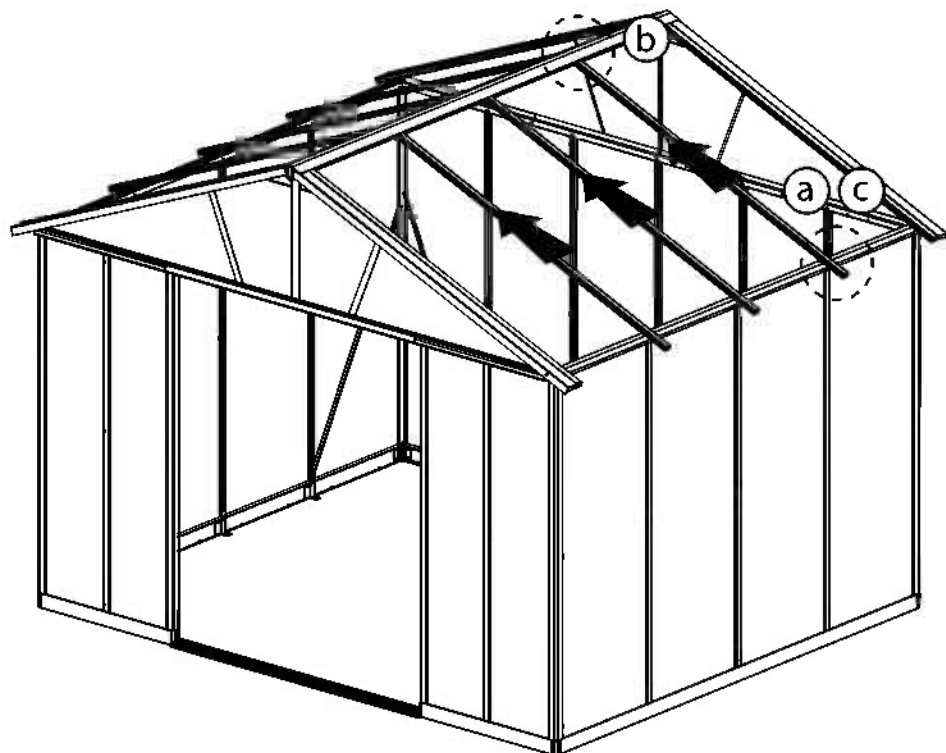

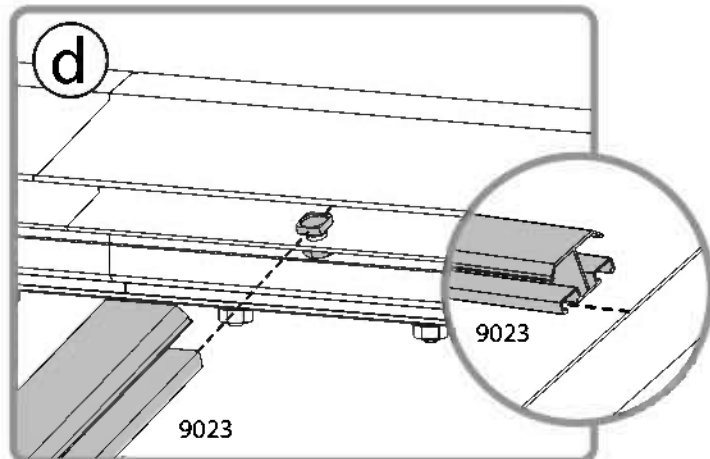
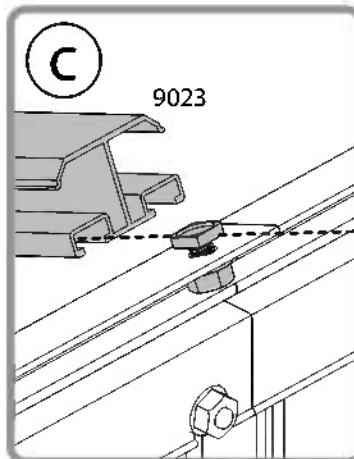
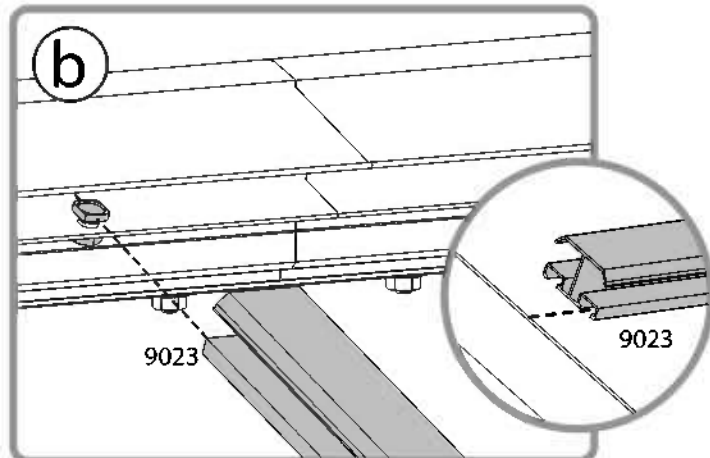
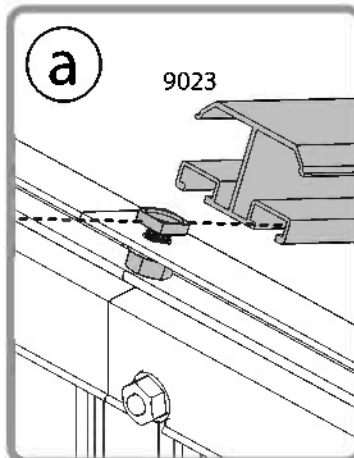
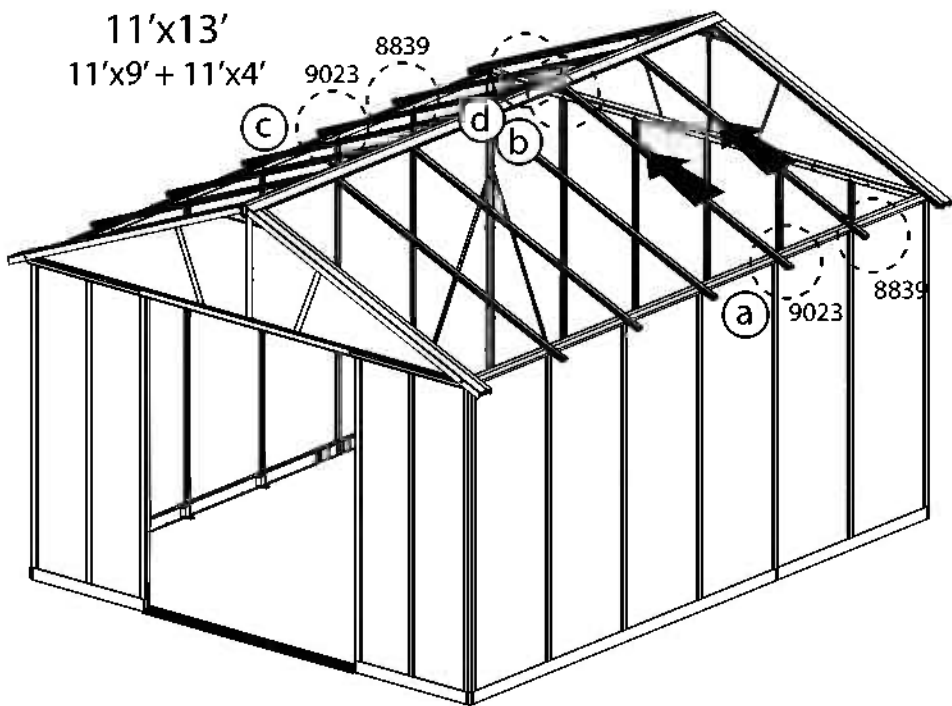

45



Slow down and be careful when sliding the panels in.



9030.....



..... 8



Extension Kit

9030.....

..... 4

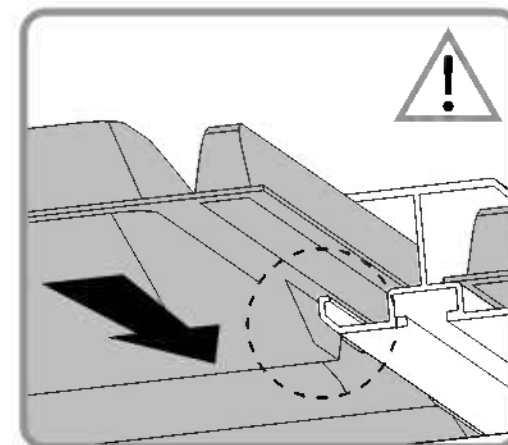
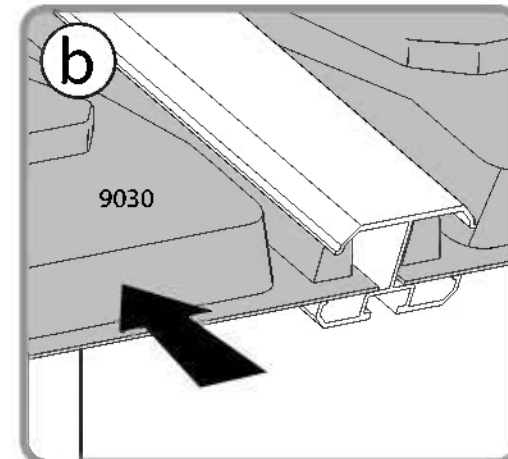
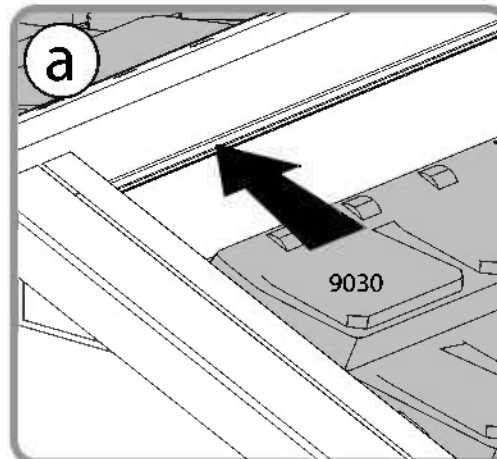
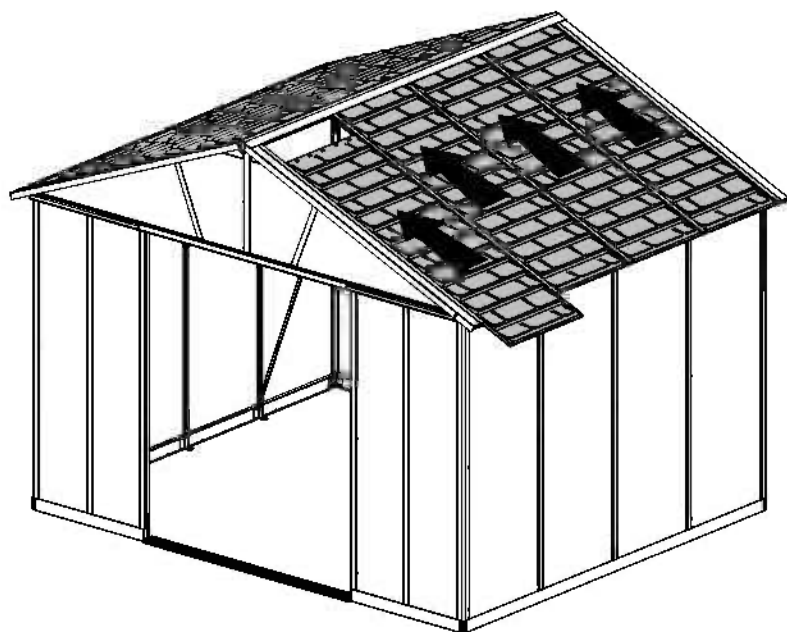

- EN** Slow down and be careful when sliding the panels in
- DE** Seien Sie langsam und vorsichtig beim Einschieben der Paneele
- FR** Ralentissez et faites attention lorsque vous y glissez les panneaux
- SP** Al deslizar los paneles hacia adentro, desacelere y tenga cuidado



- 9018 2
- 9019 2

- 7985 2
- 411 8
- 466 8



11'x13'
11'x9' + 11'x4'

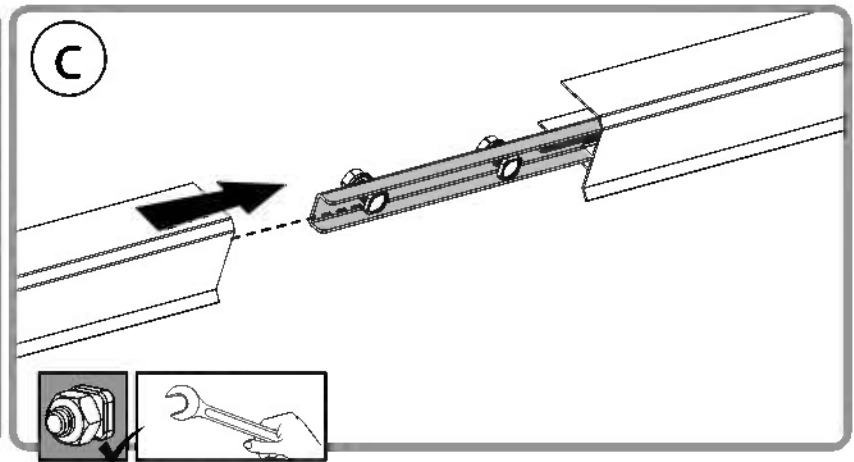
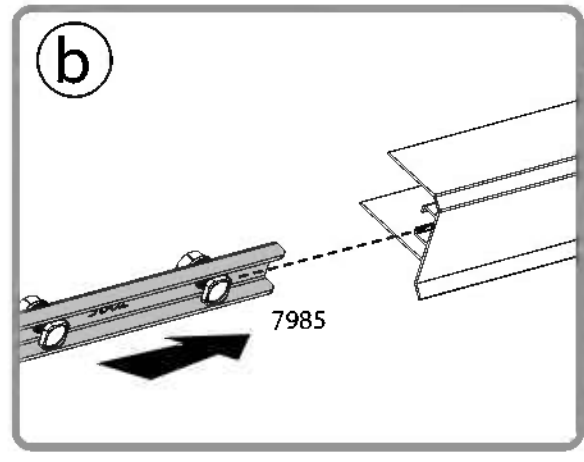
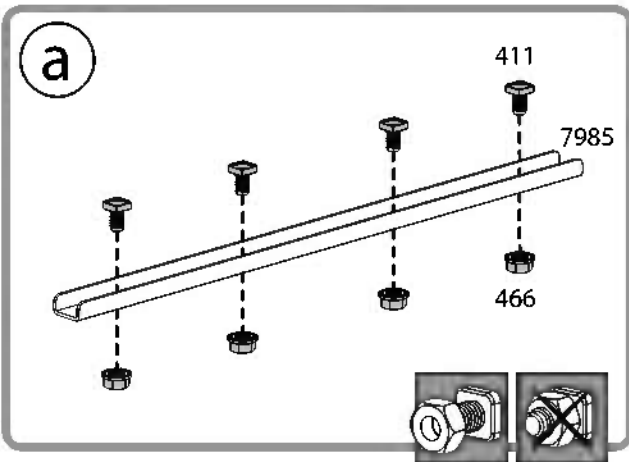
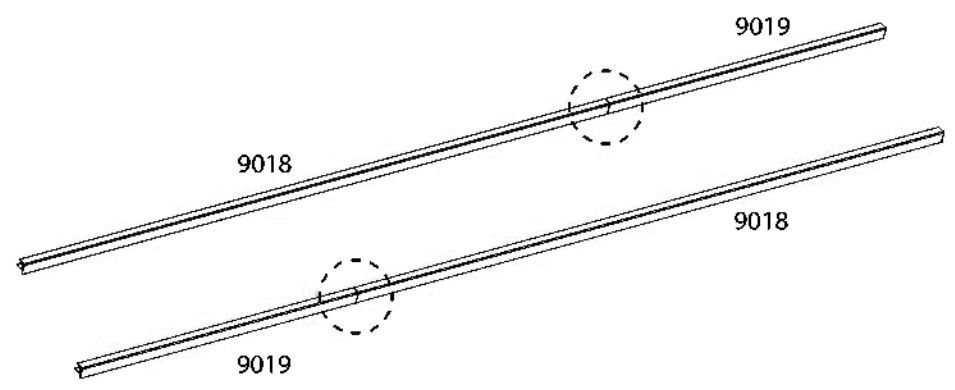



9018.....

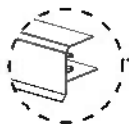
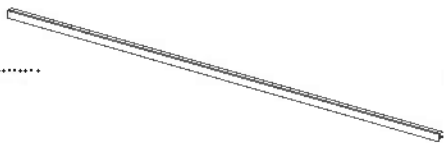

2

411.....



10

466.....



10

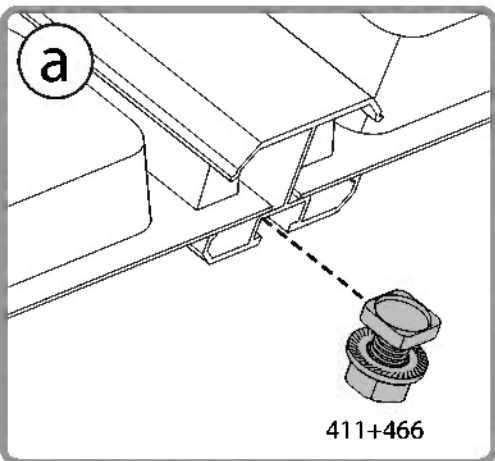

a

411+466



10 mm
13/32"

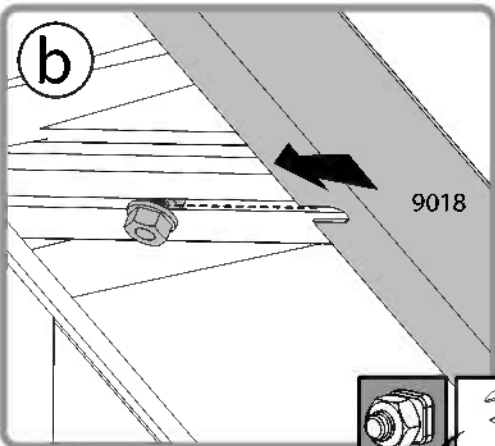

b

9018

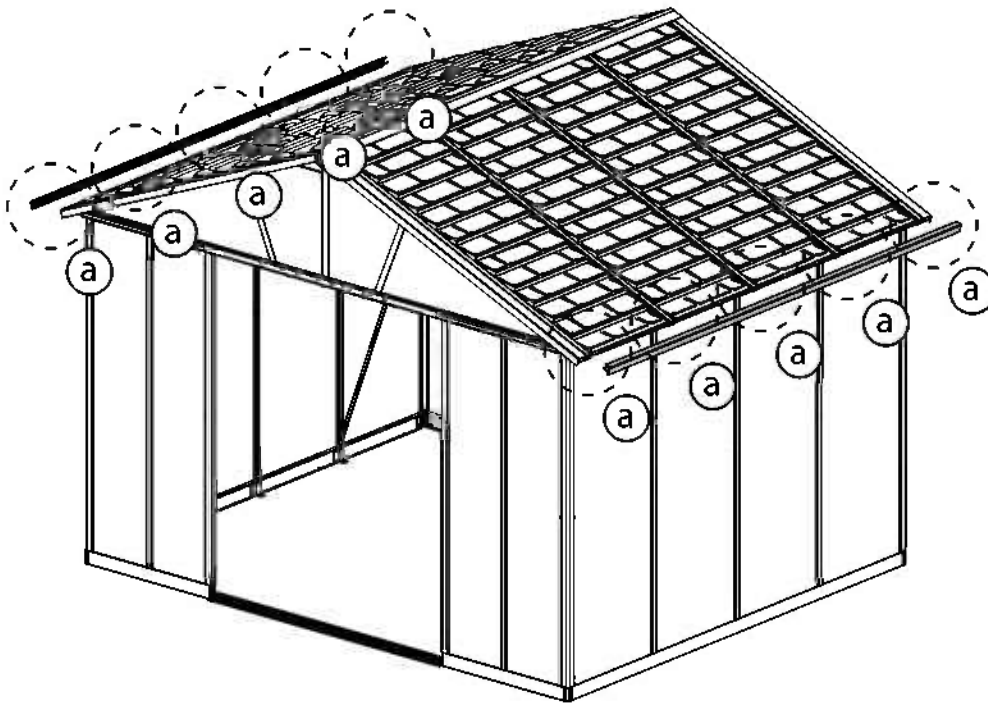
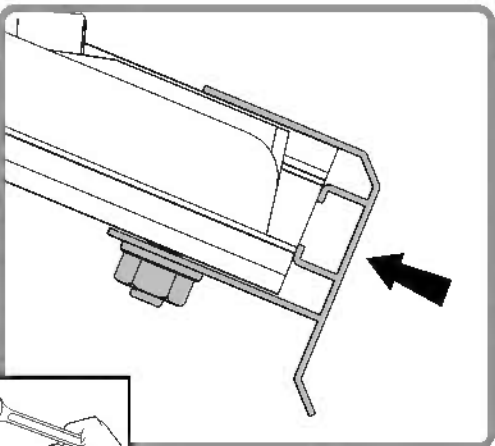

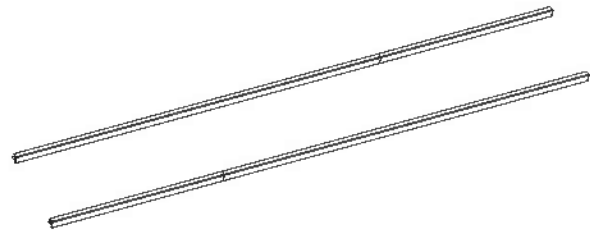

411 14

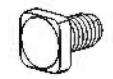

466 14

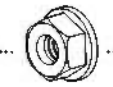

Extension Kit

11'x13'
11'x9' + 11'x4'

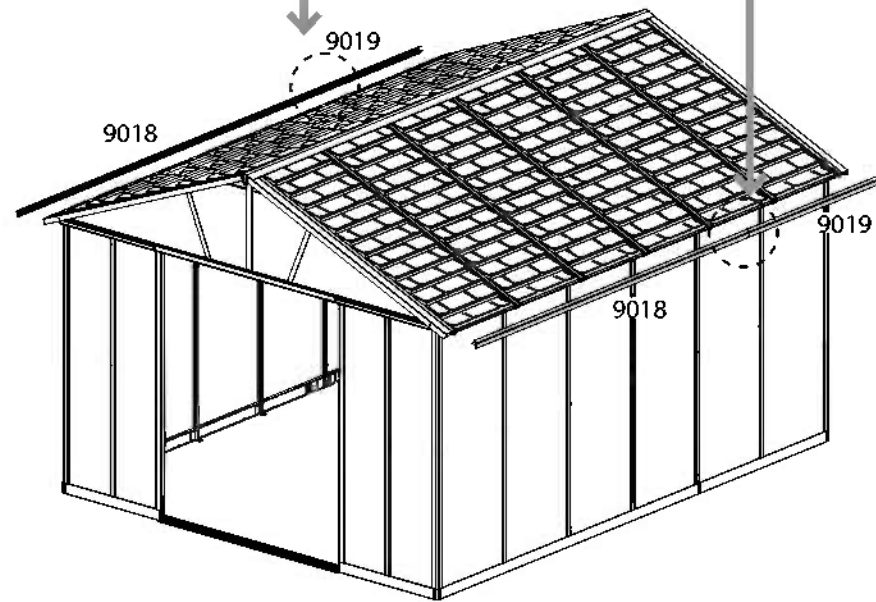
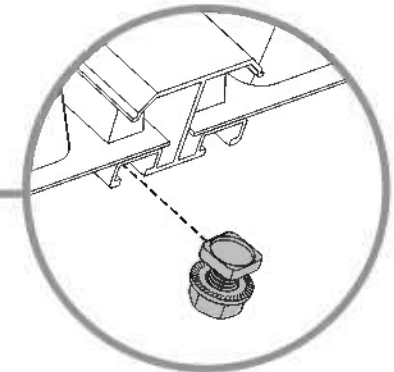
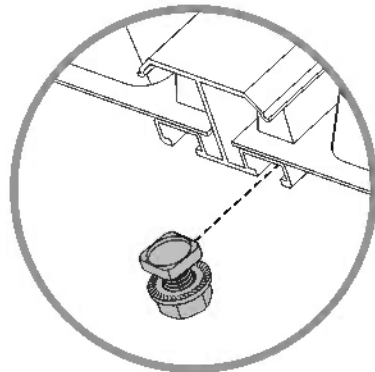

49



Make sure the distance between the wall's aluminum profiles and gutter is identical prior to tightening the screws on the inside.

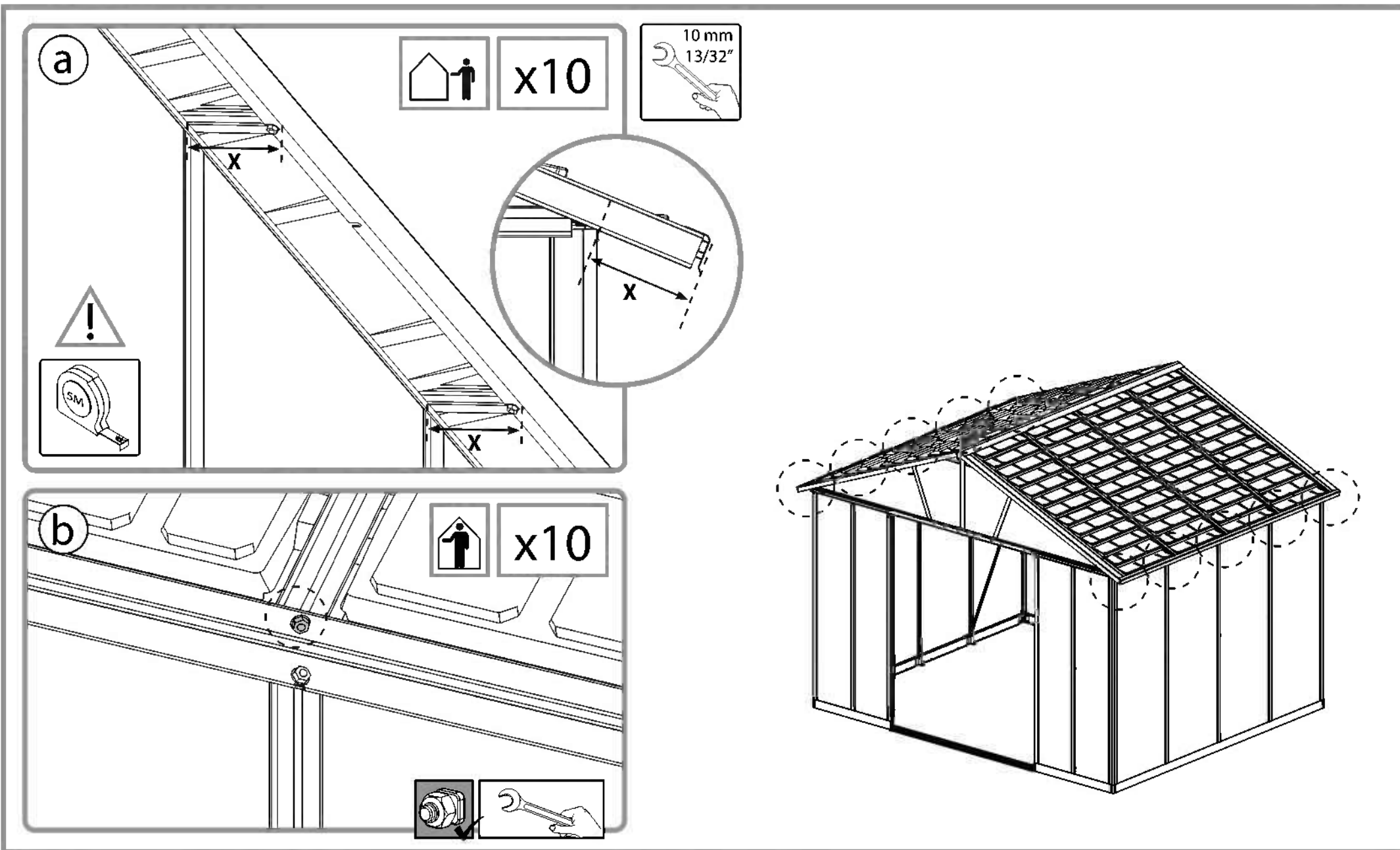

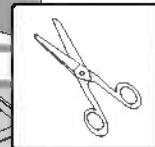
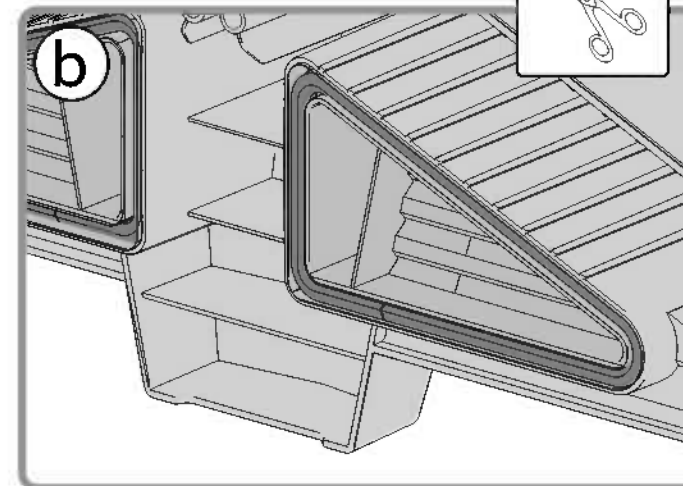
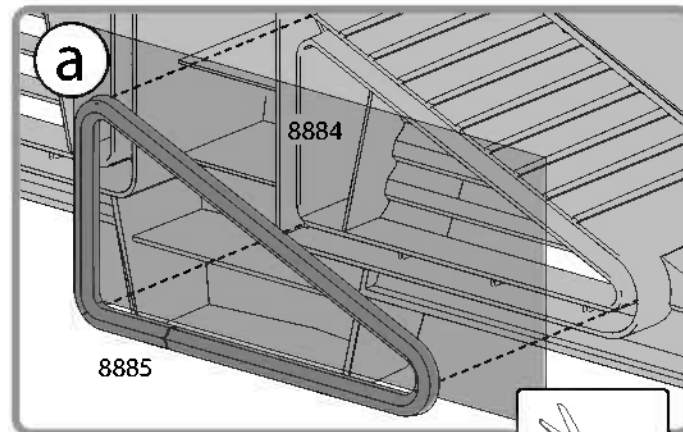
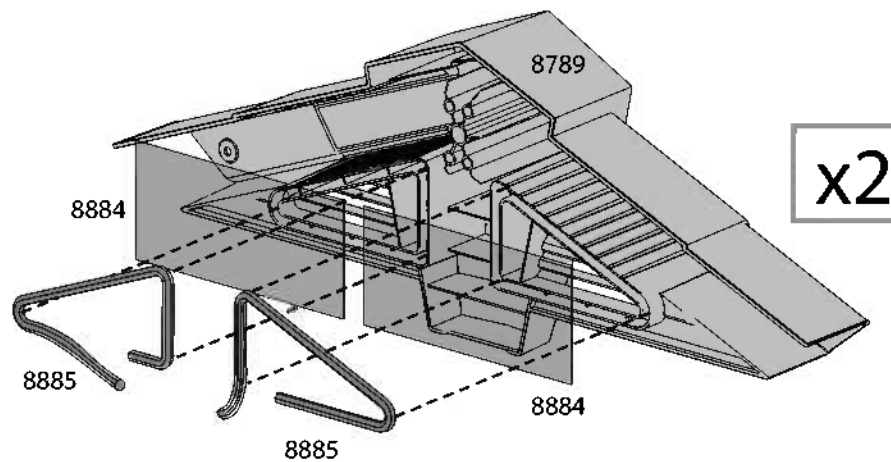
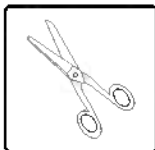
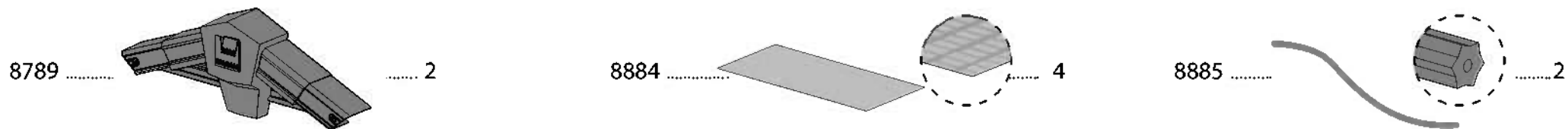



4008  4

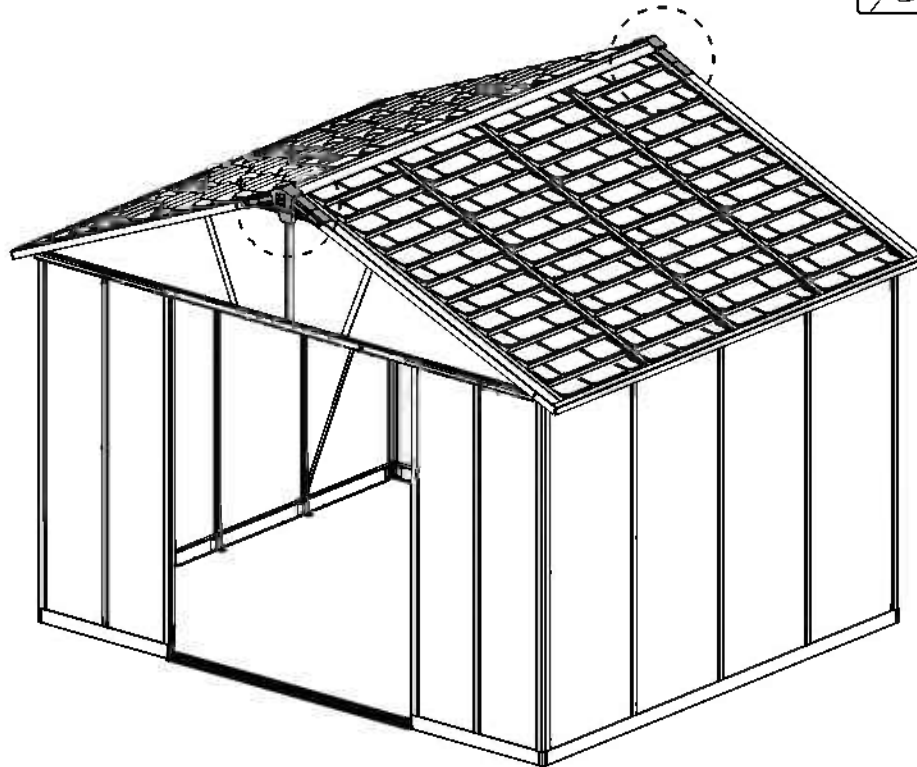
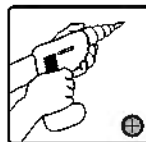
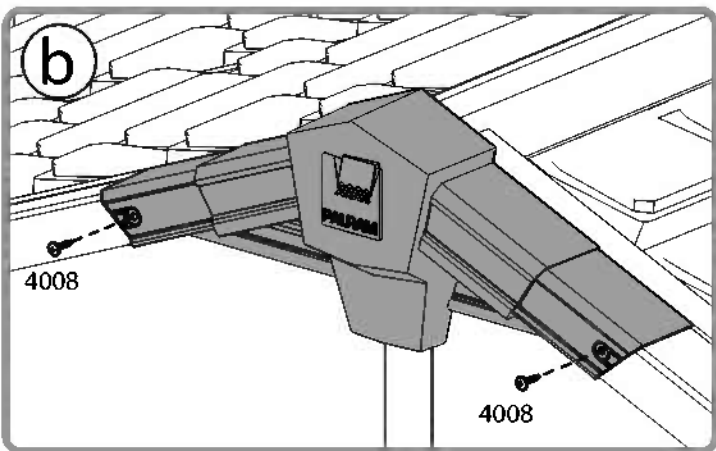
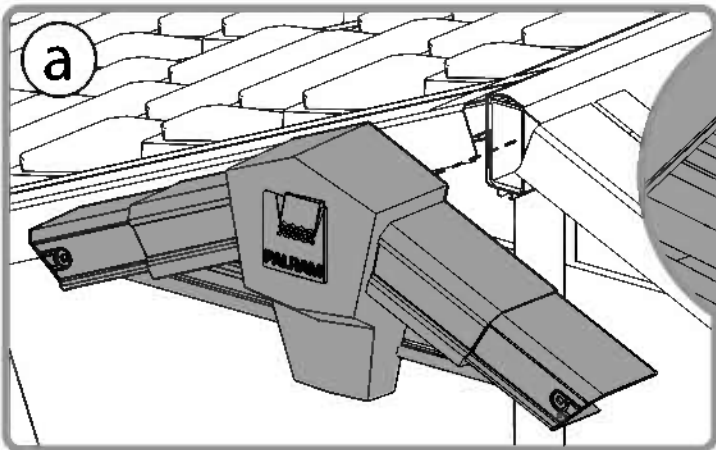

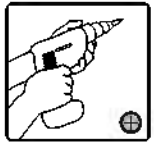
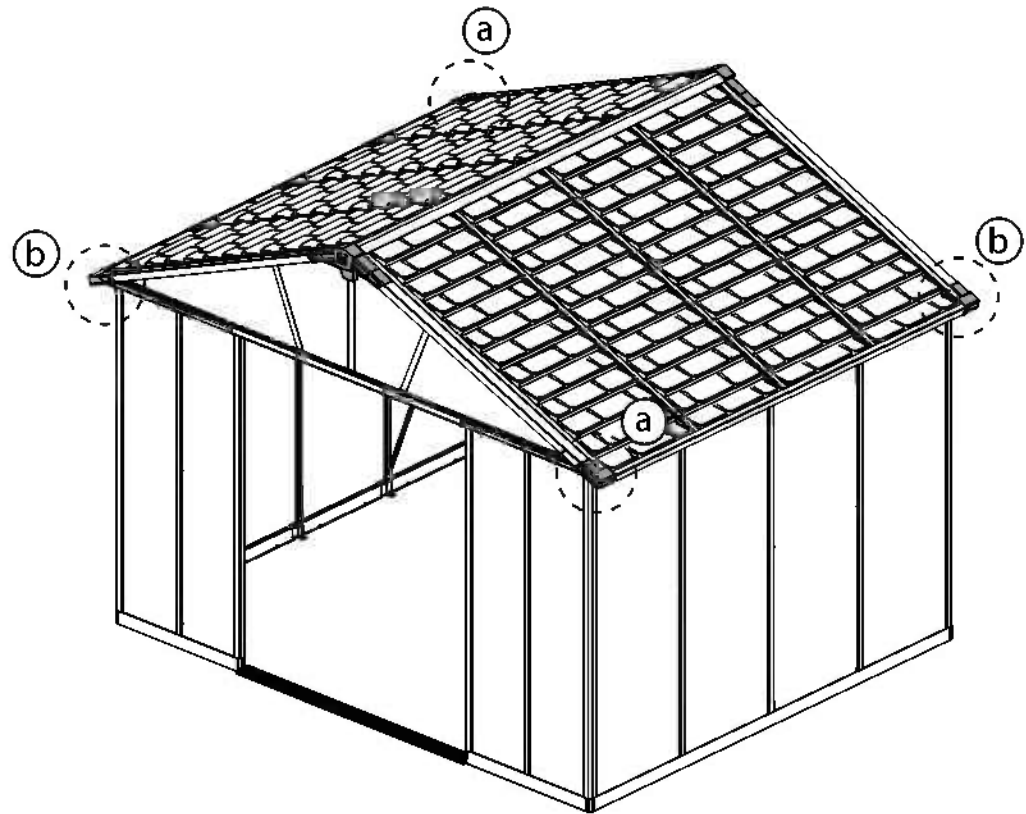
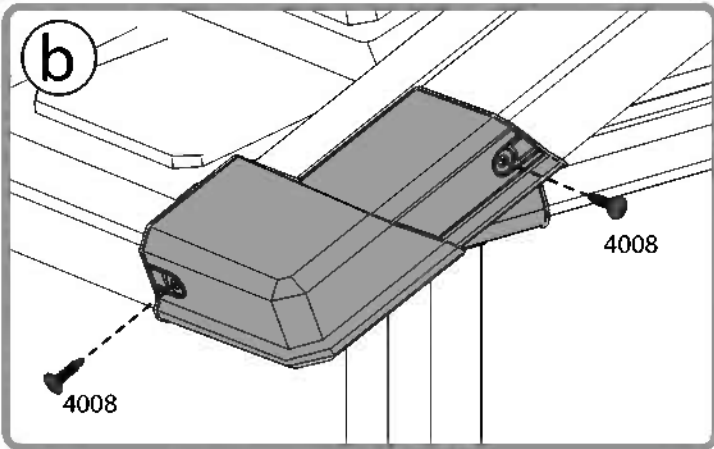
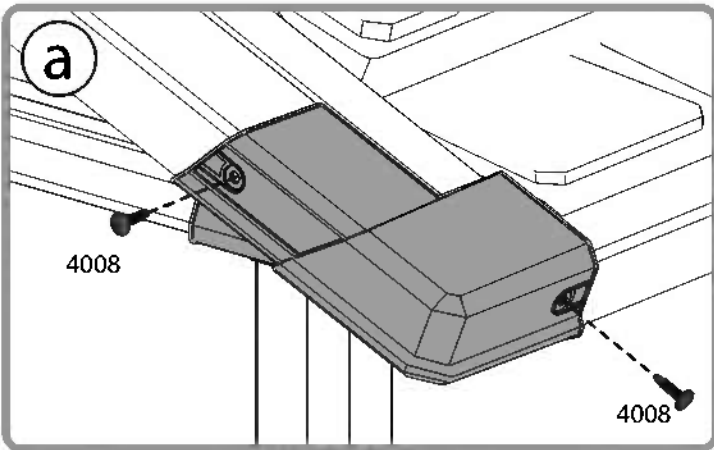
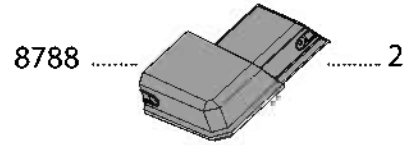
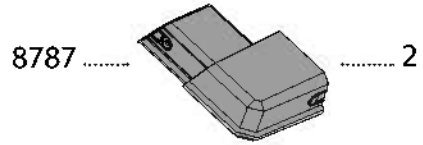



8883 4

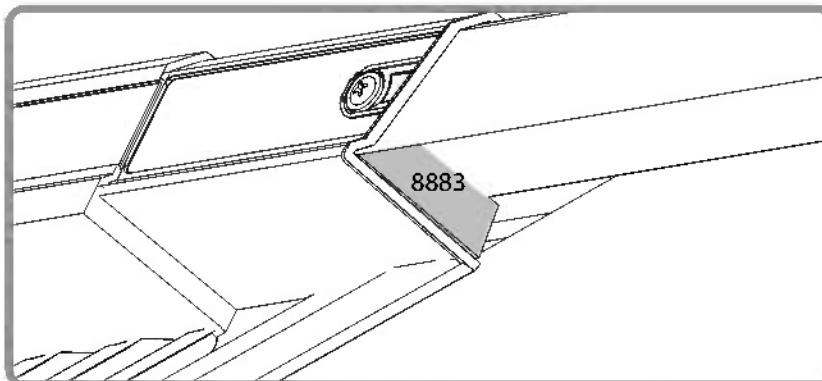
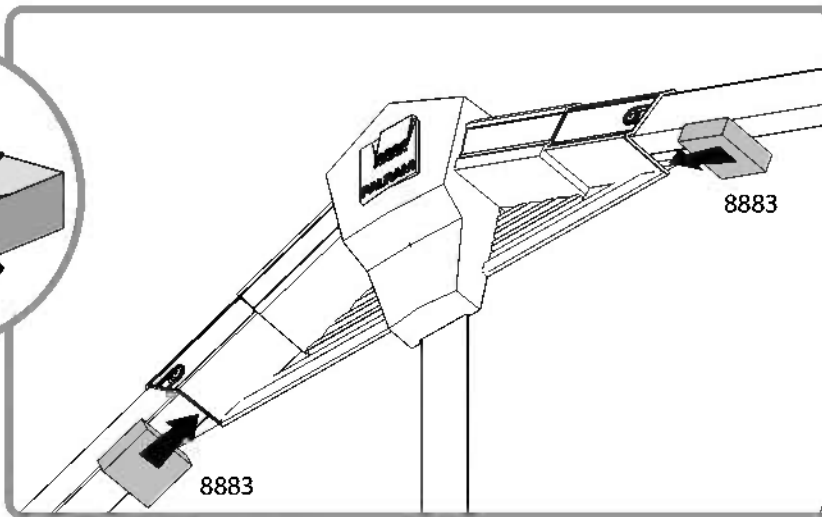
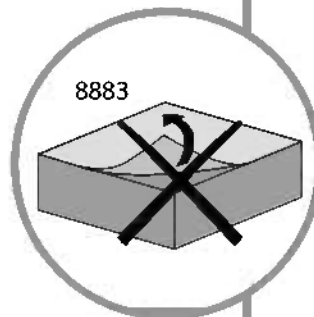
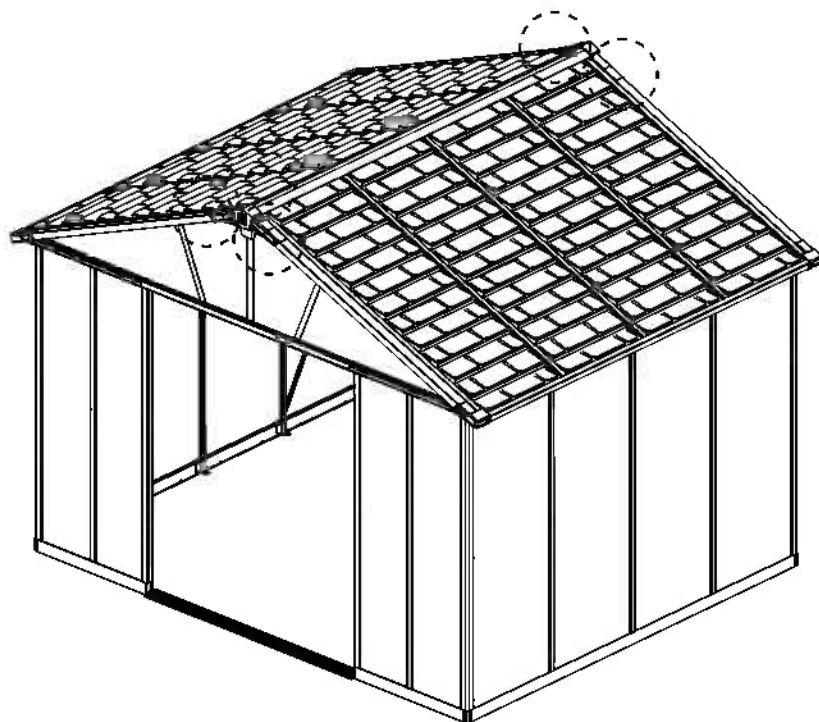
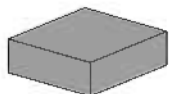

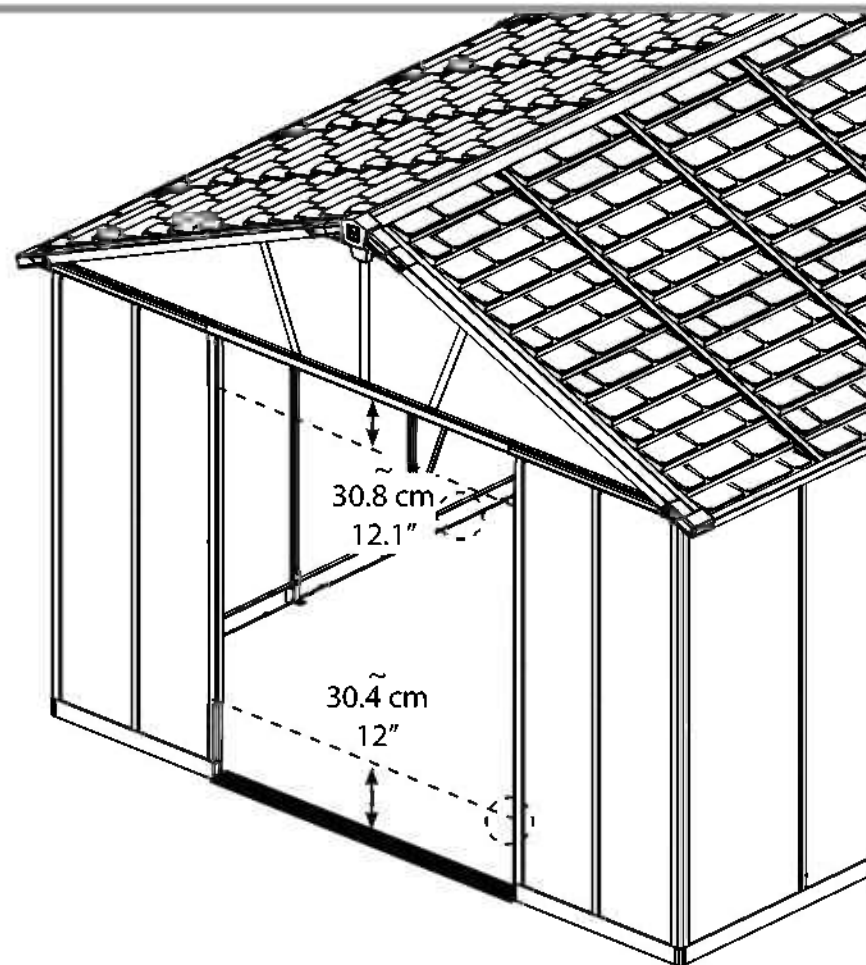
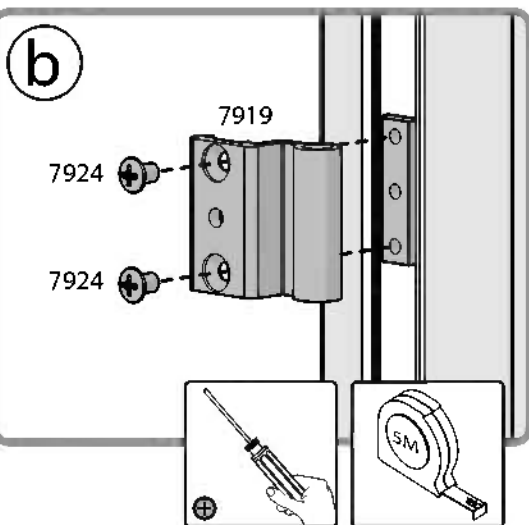
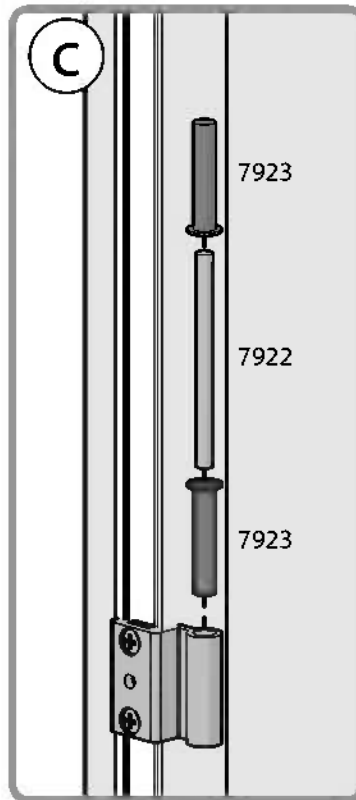
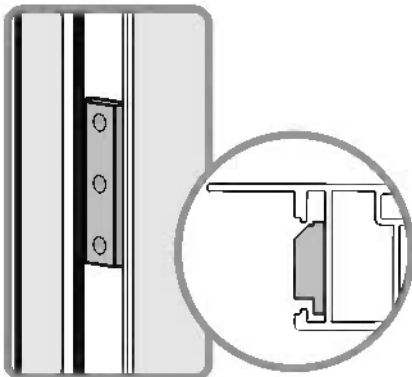
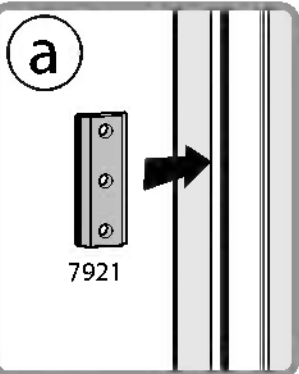
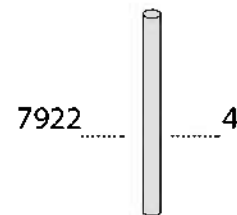
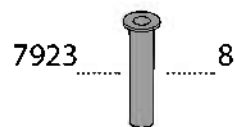
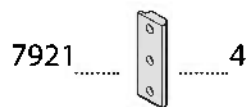
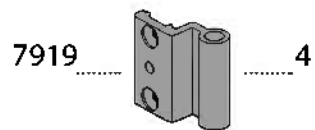



8836 1

8837 1

8833 6

7524 6

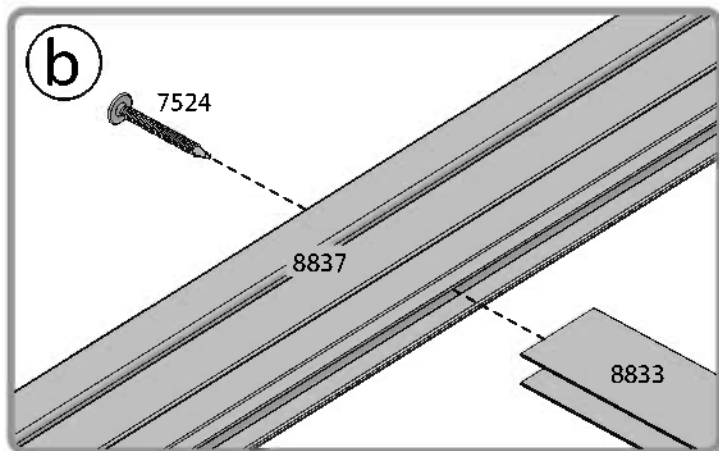
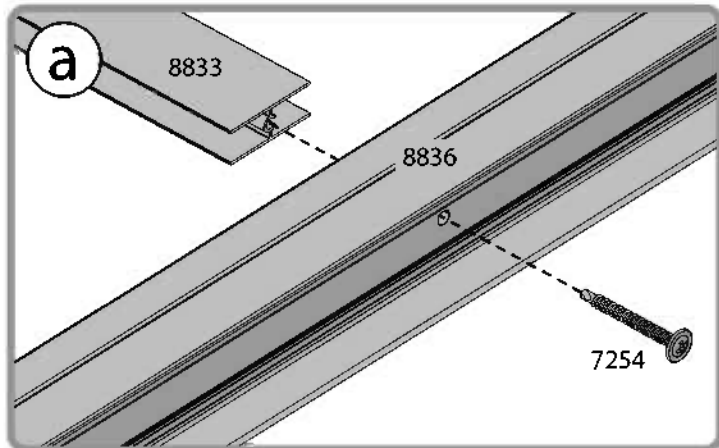

8833

8836

8837

a

b

8836

8837

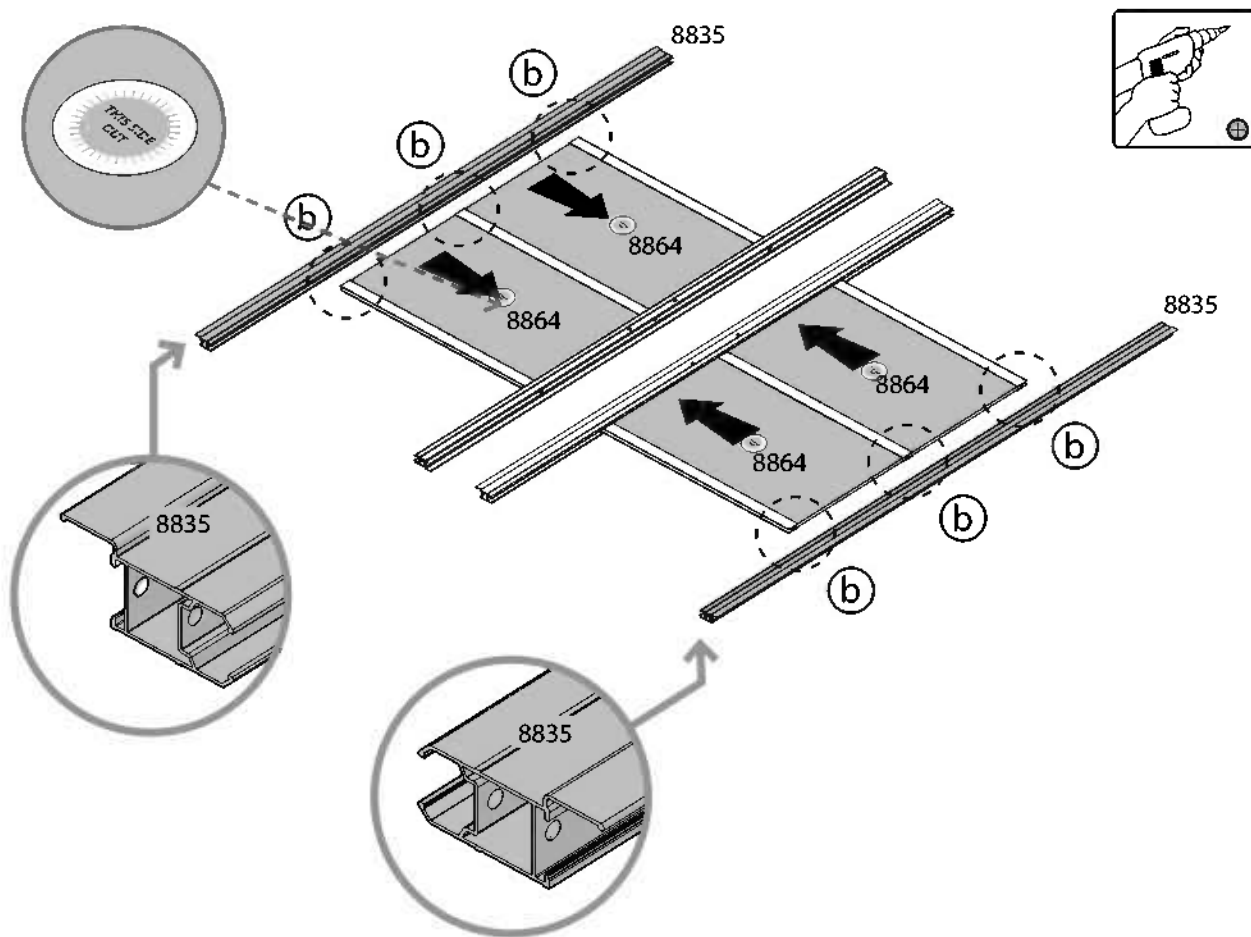
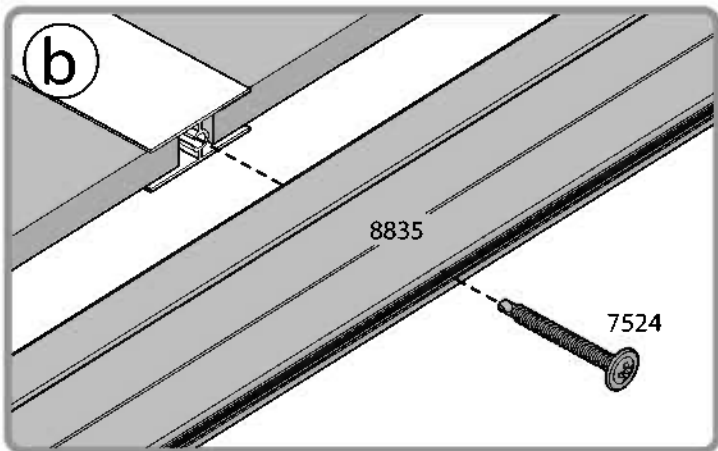
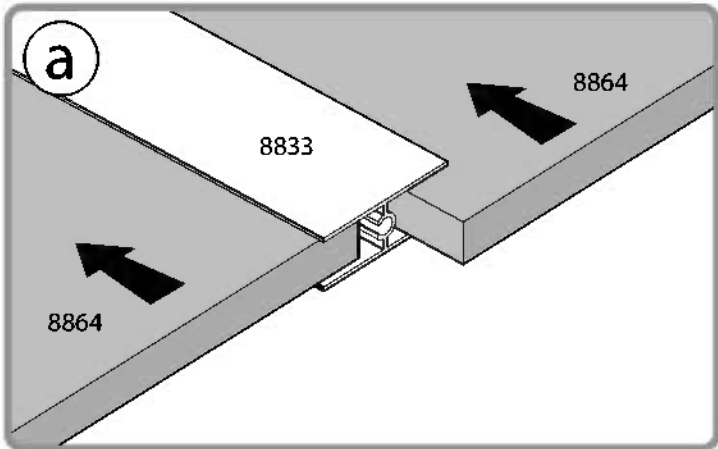
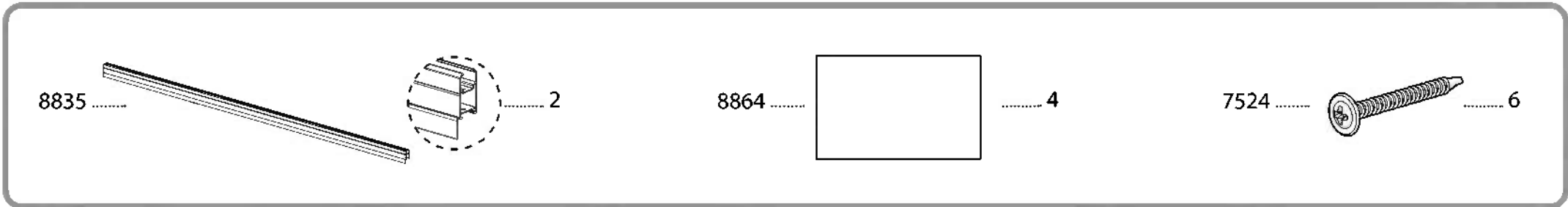

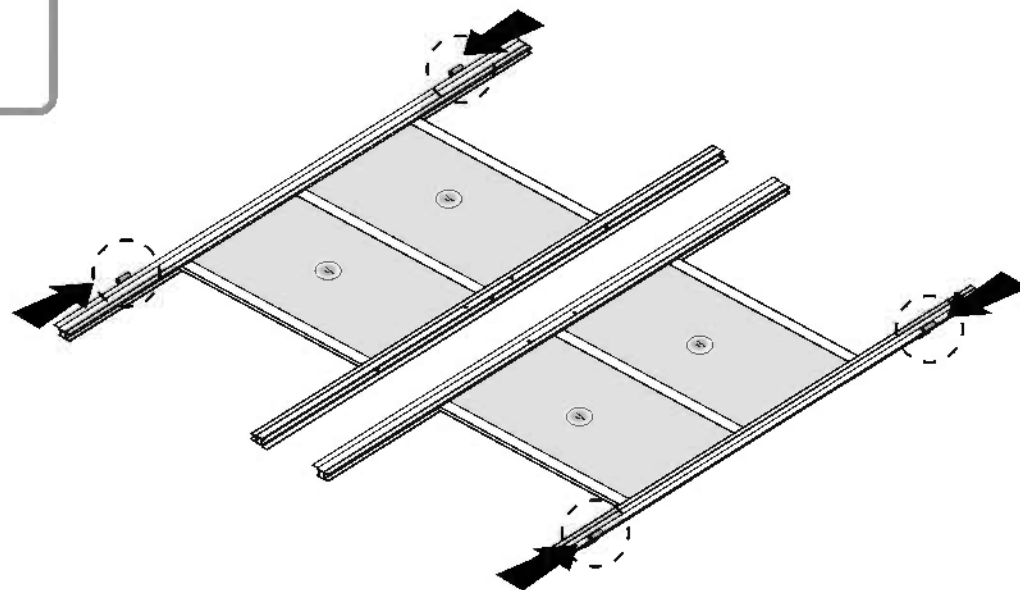
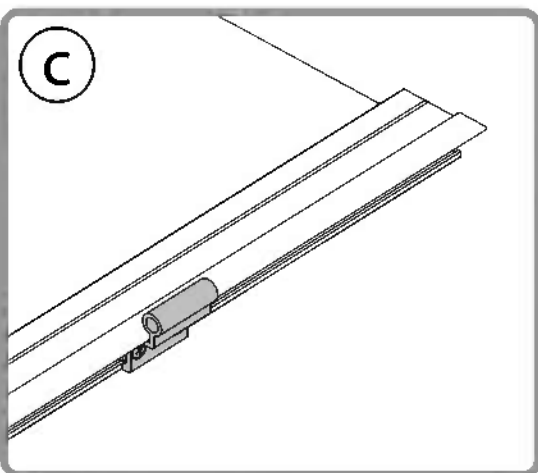
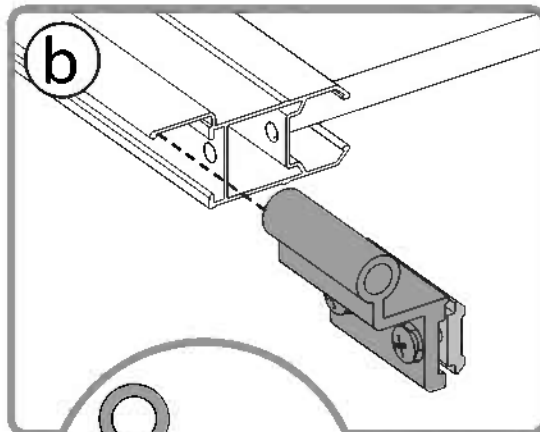
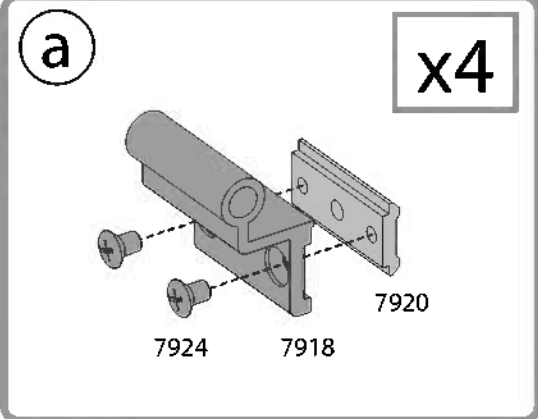
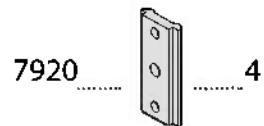
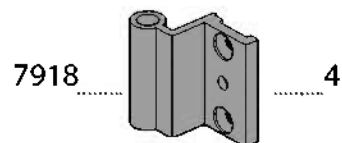

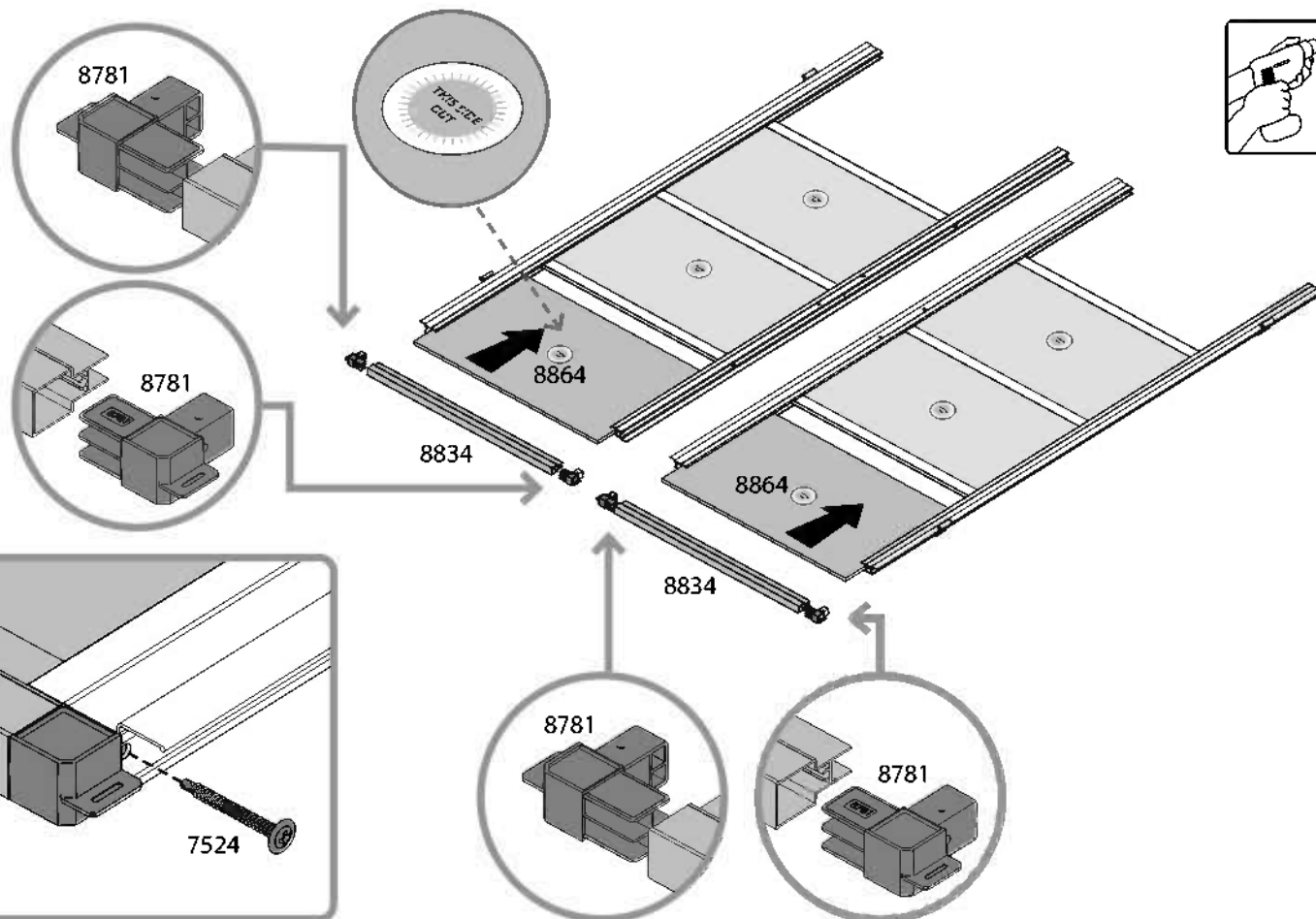
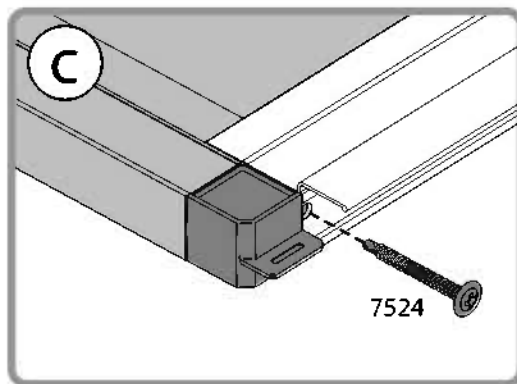
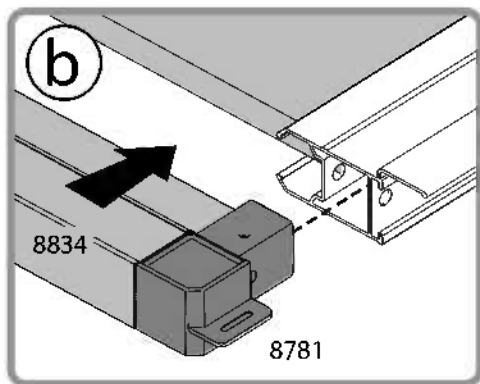
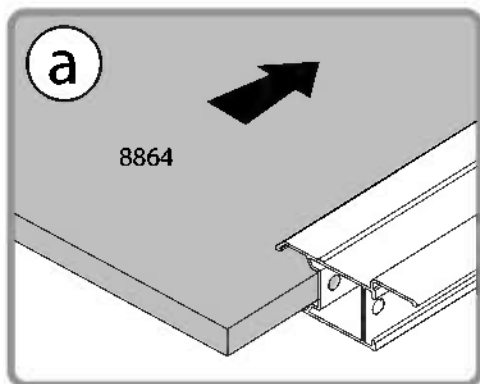
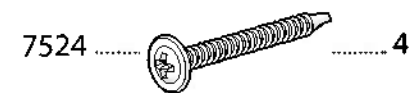
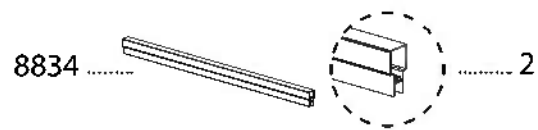



- 8864 2
- 8834 2
- 8782 4
- 7524 4

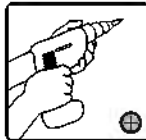
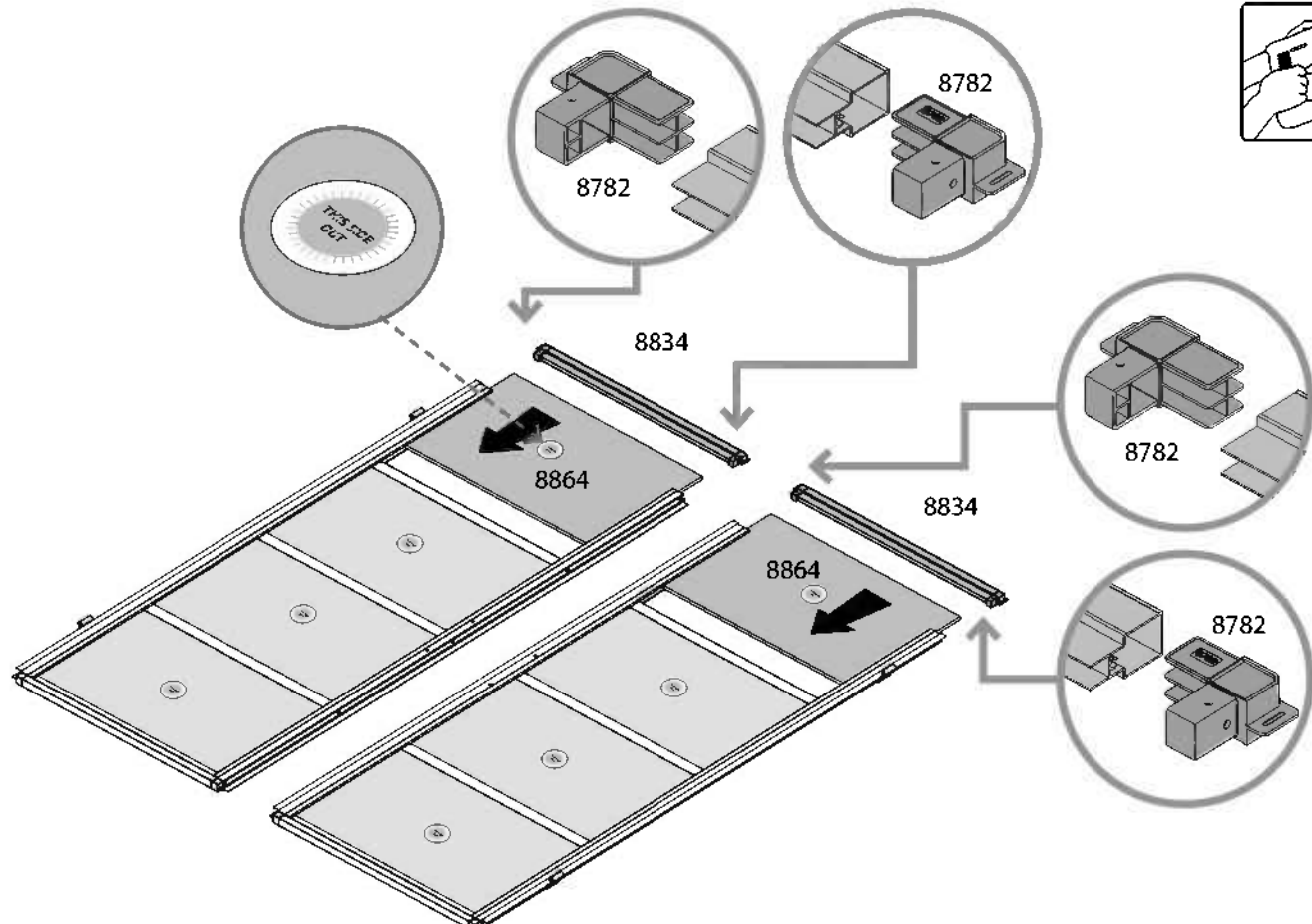
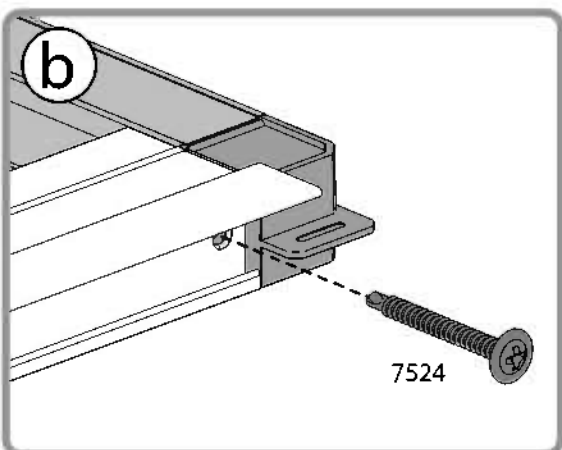
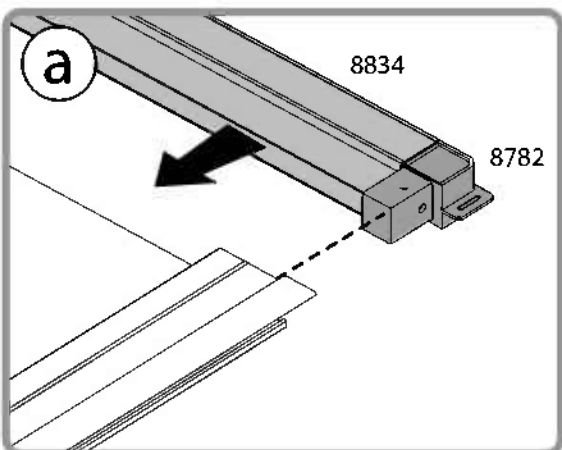

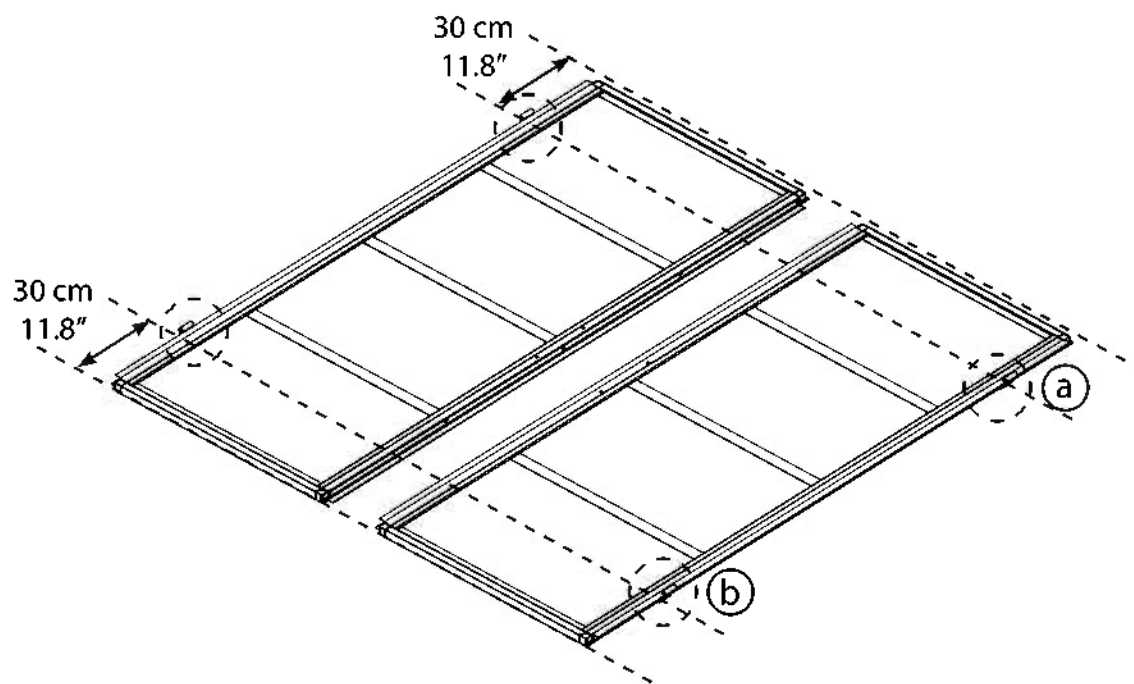
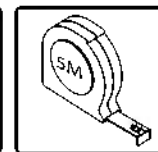
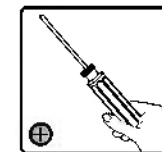
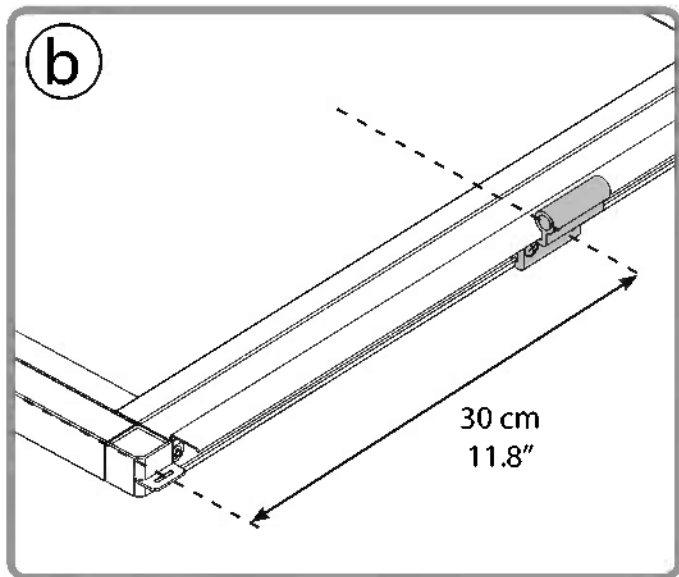
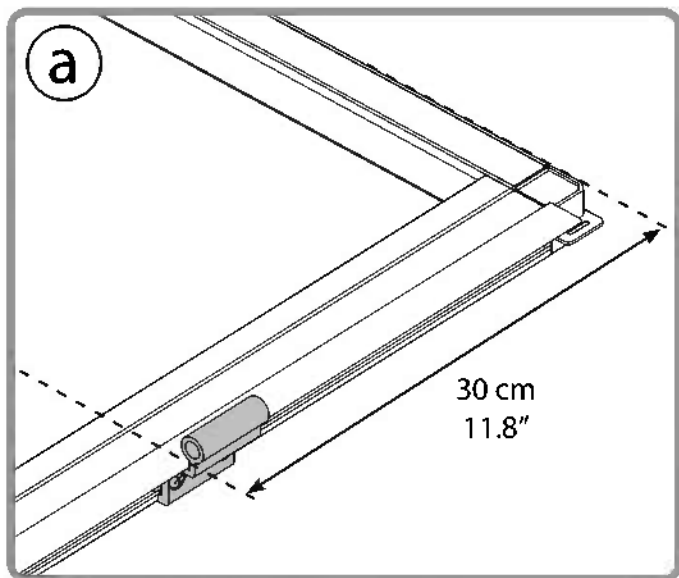

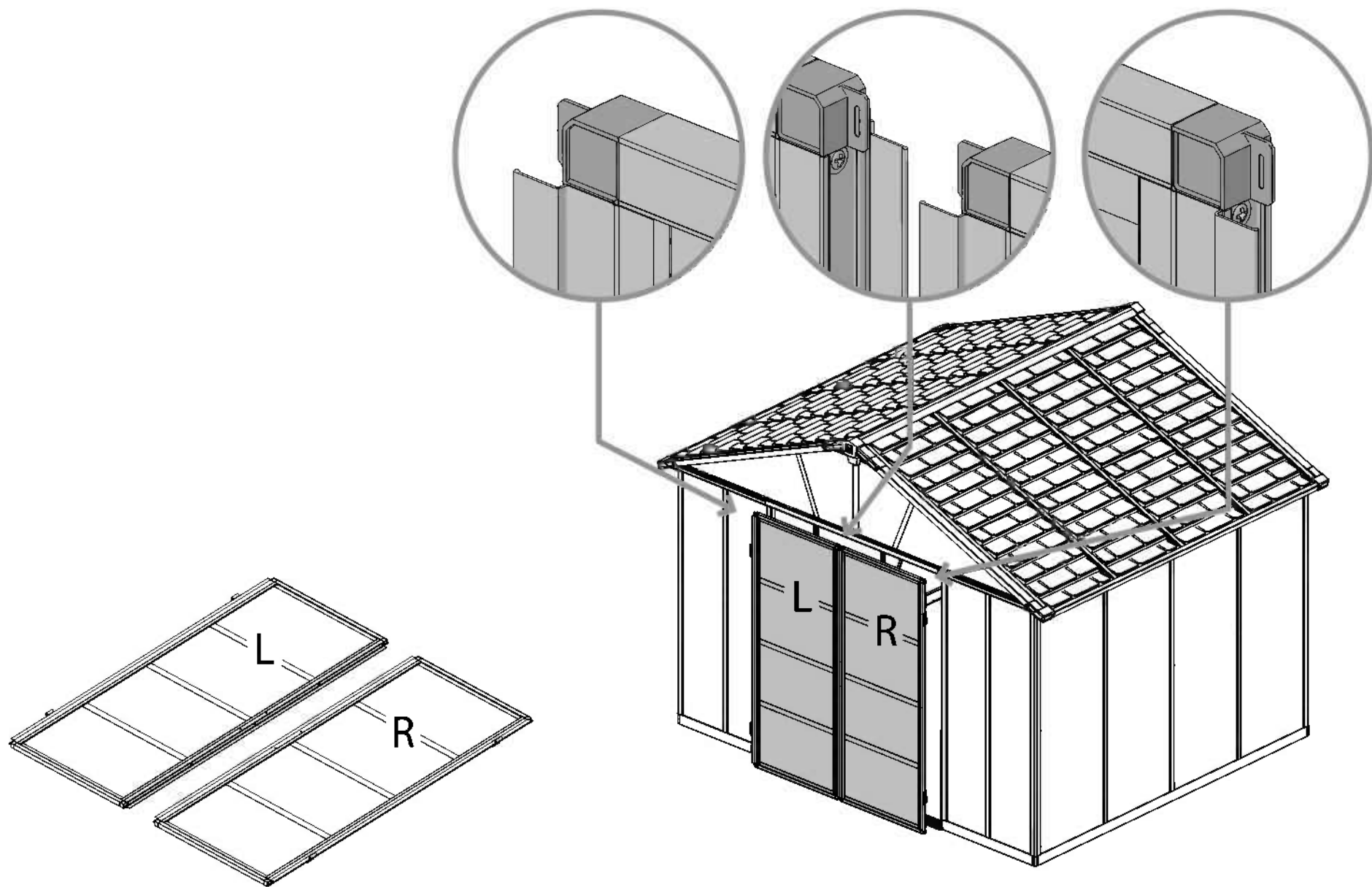

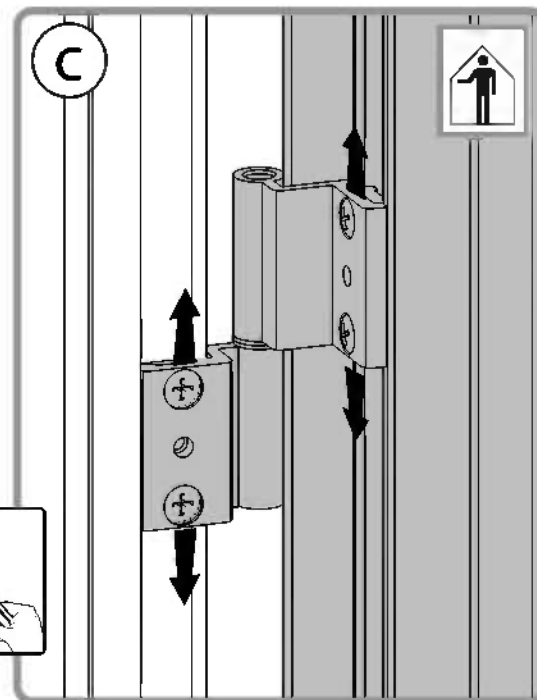
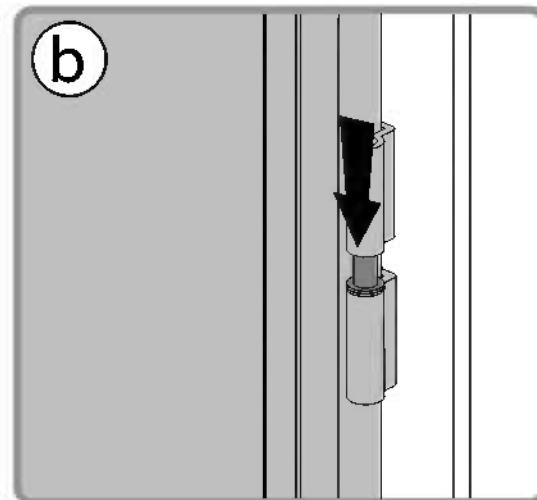
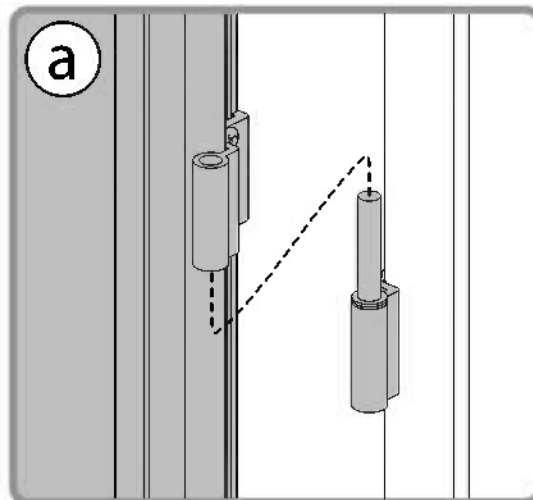
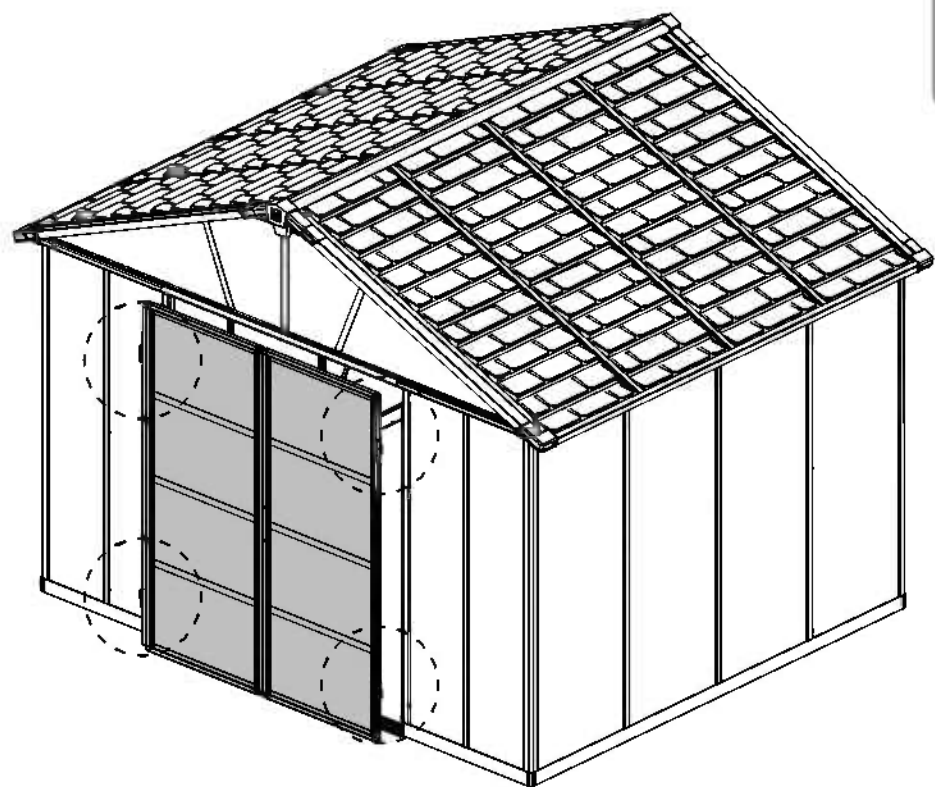

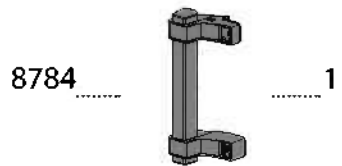

8784 1



8785 1

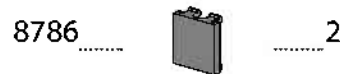

8786 2

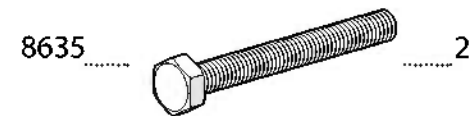

8635 2



466 2

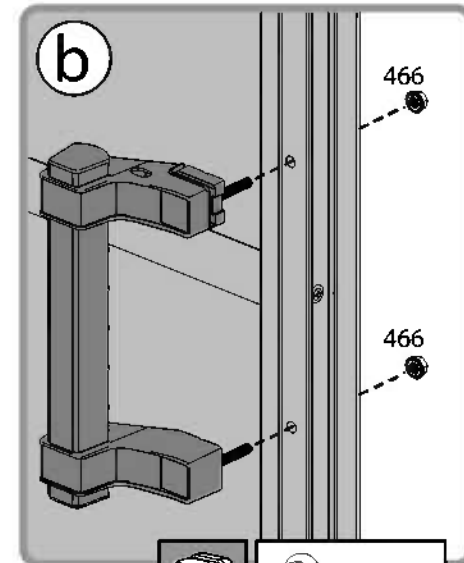
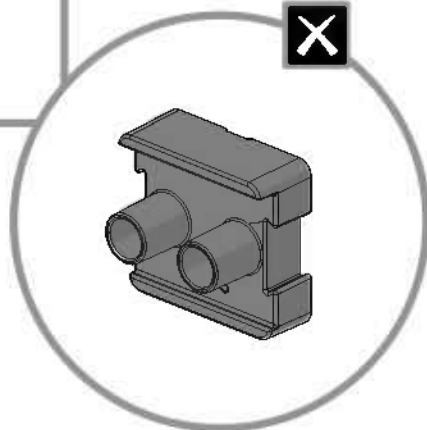
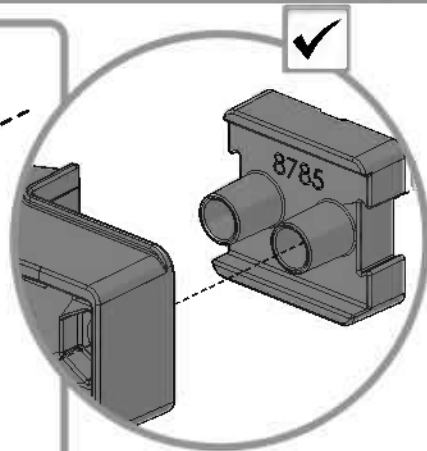
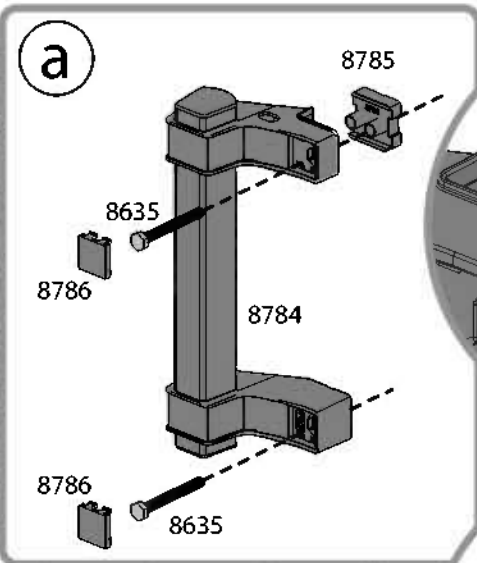
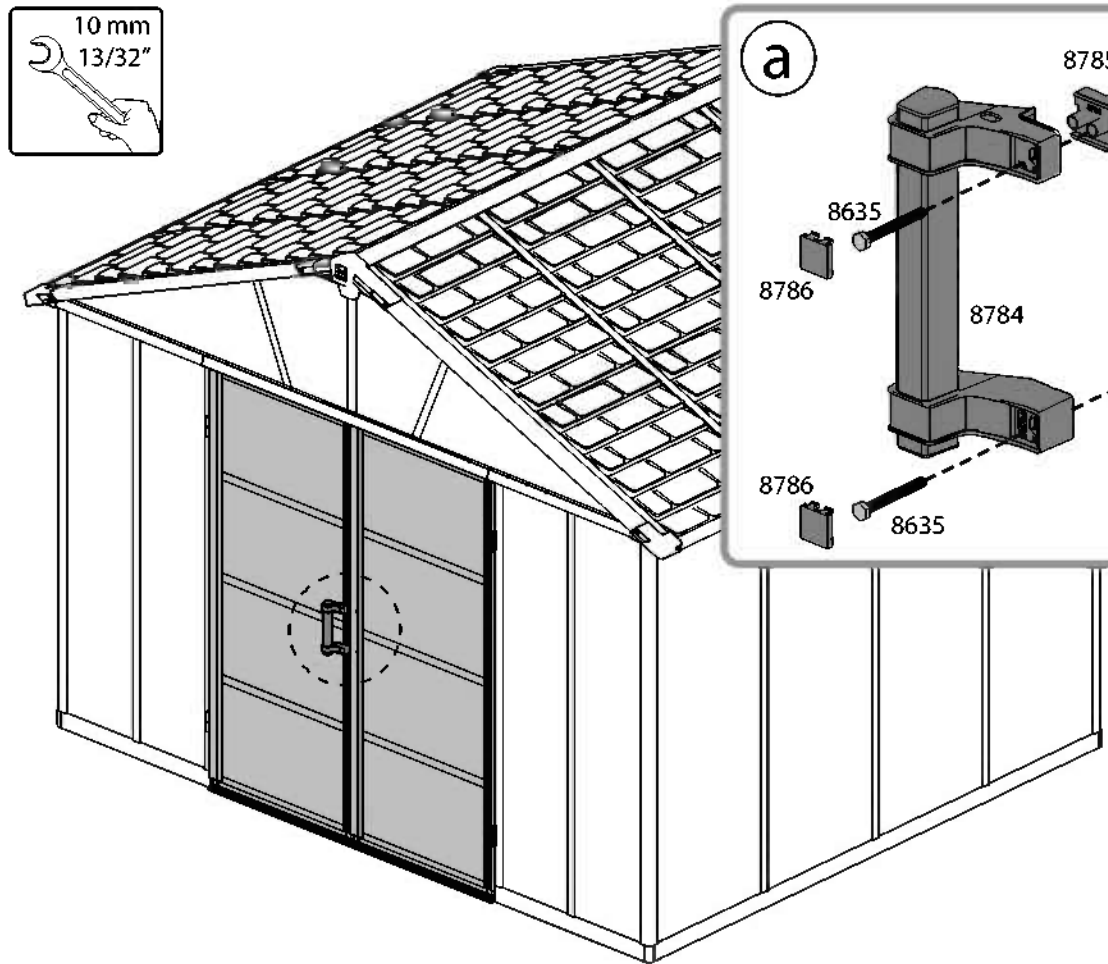
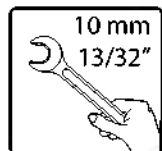

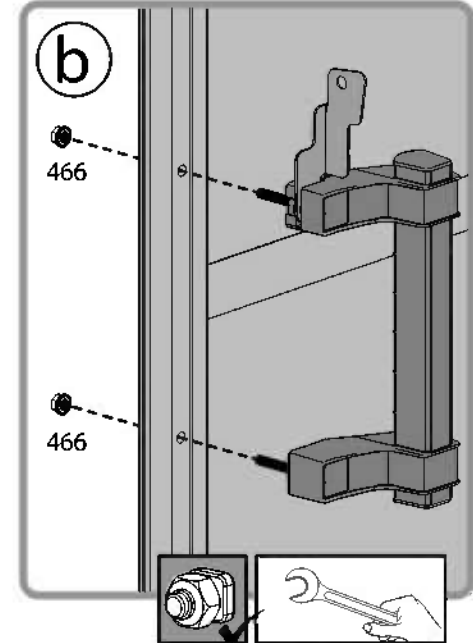
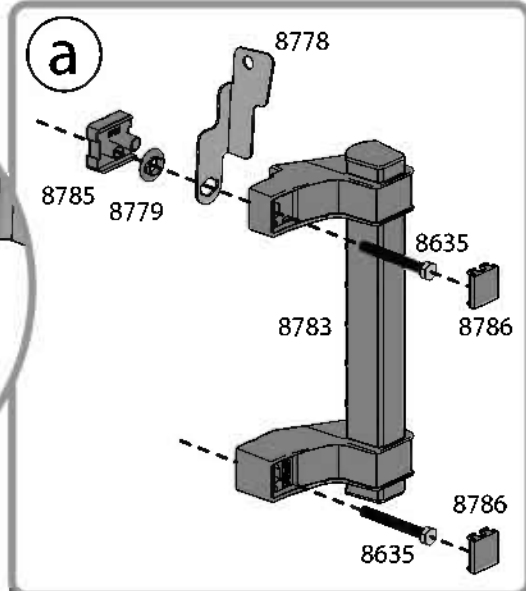
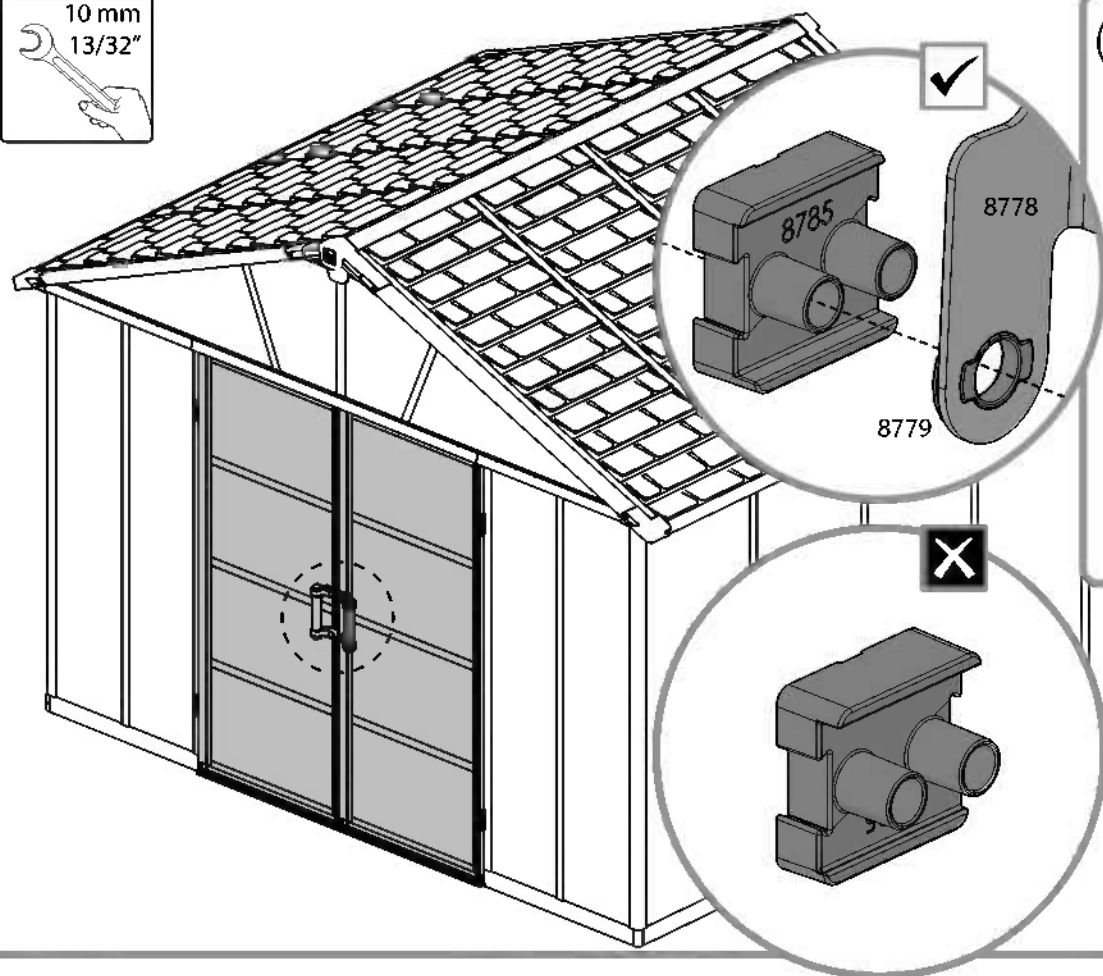
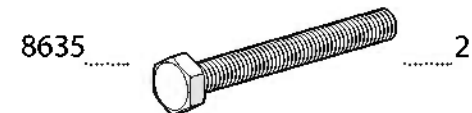
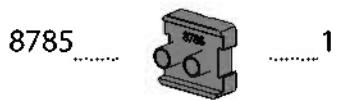

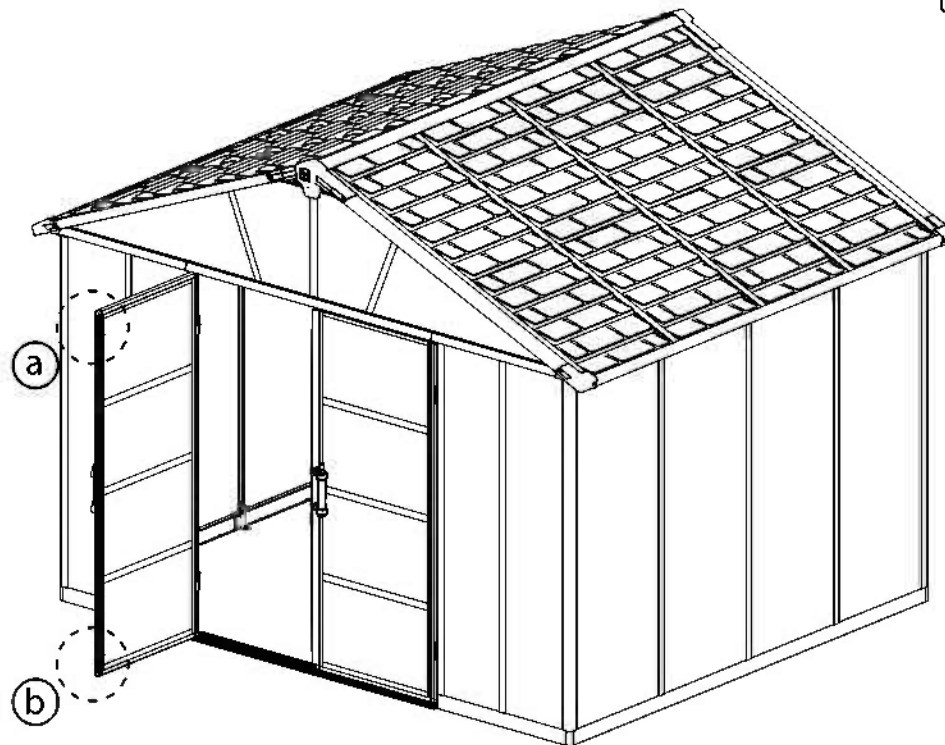
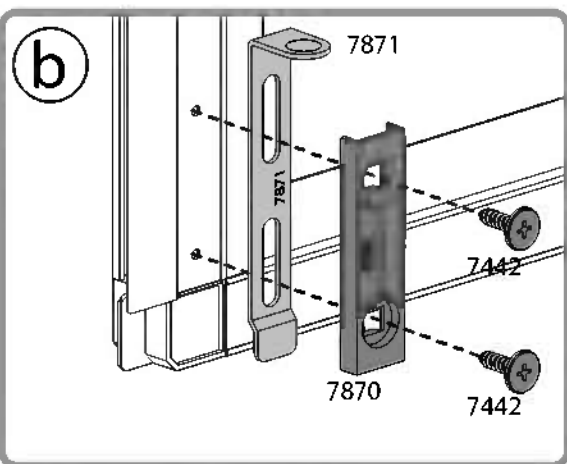
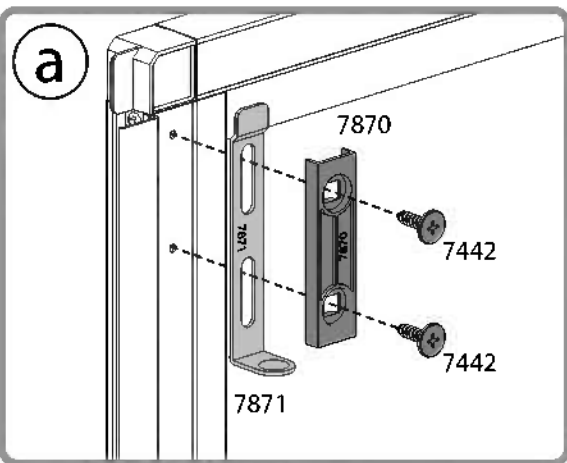
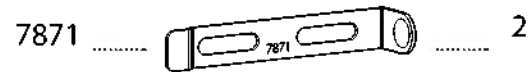
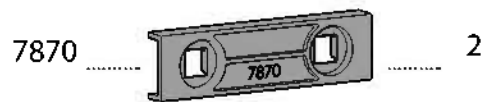

i Make sure the shed is leveled prior to anchoring it to the surface of your choosing. Use suitable screws and plugs (not supplied).

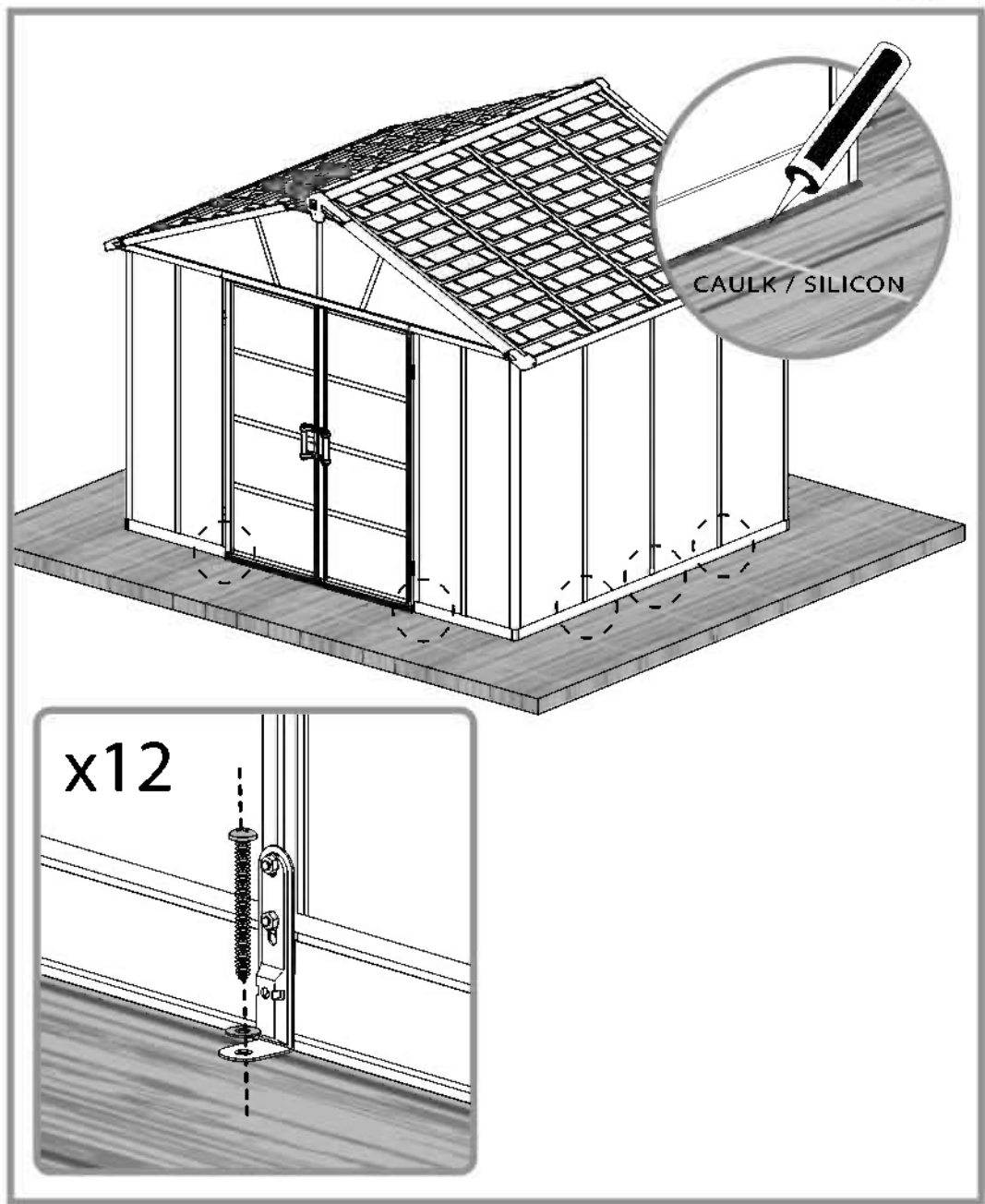
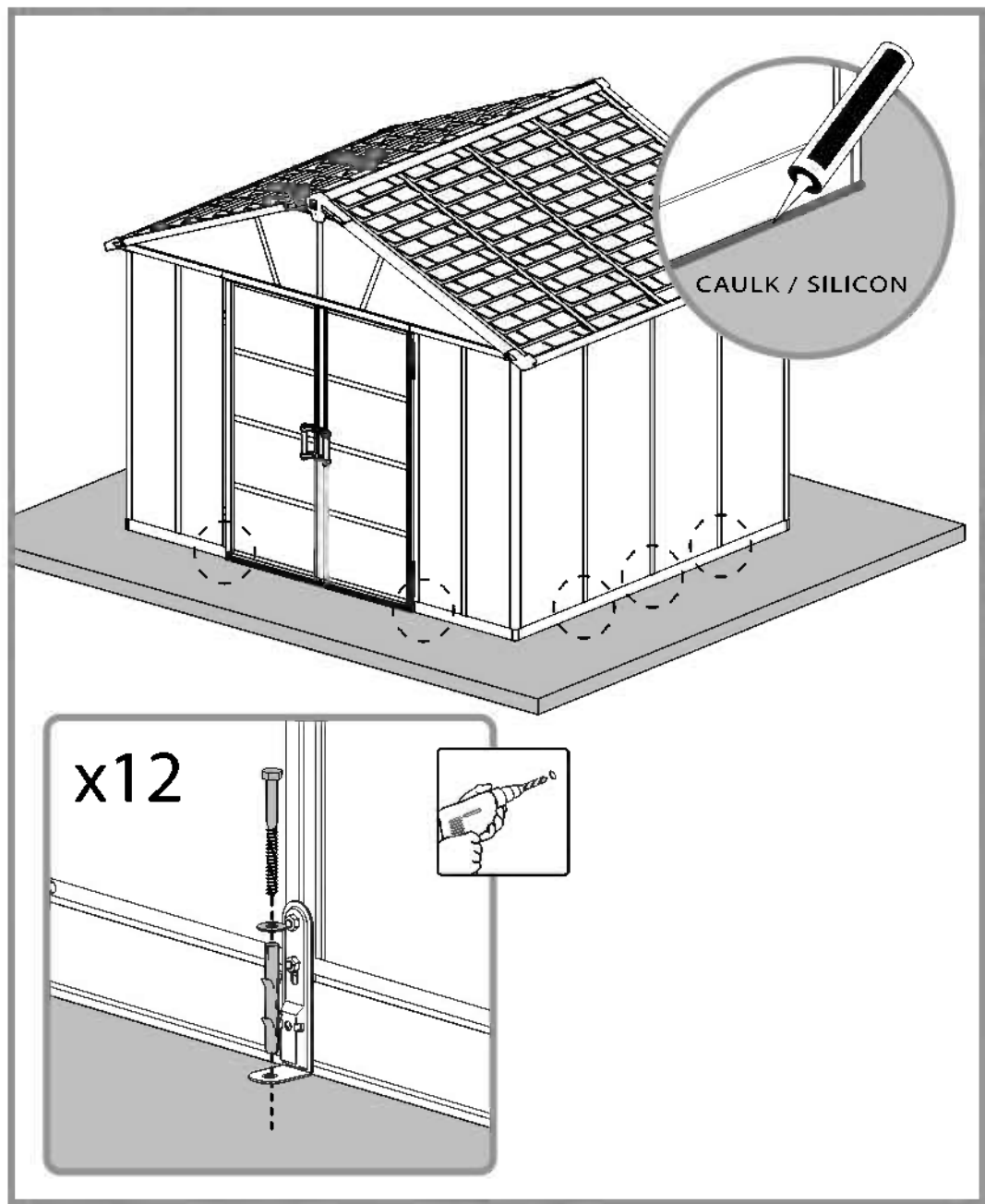

EN

PALRAM - CANOPIA | 15 YEAR LIMITED WARRANTY

Palram Canopia Ltd (Company number: 512106824) whose registered office is at Teradion Industrial Park, M.P. Misgav 2017400, Israel ("Canopia") warrants that the product will be free from defects in material or workmanship for a period of 15 years from the original date of purchase. • This warranty is valid only if the product is installed, handled, cleaned, and maintained in accordance with Canopia's written specifications. • This warranty does not cover defects resulting from normal wear and tear including, but not limited to: damage caused by use of force, incorrect handling, inappropriate use, negligence, accidents, impact from foreign objects, vandalism, pollutants, alteration, painting, damage resulting from cleaning with incompatible detergents or minor deviations of the product. • This warranty does not apply to damage resulting from "acts of Nature", which includes but is not limited to hail, storm, tornado, hurricane, blizzard, flood, or fire. • Upon submitting proof of purchase and evidence of the claimed product failure, and subject to reporting the failure in writing within 30 days after discovery of the defect, Canopia, at its sole discretion, will replace defective parts of the Product, or refund you a prorated portion of the purchase price on a straight-line depreciated basis for the length of the warranty.

FR

GARANTIE LIMITÉE À 15 ANS DE PALRAM - CANOPIA

Palram Canopia Ltd (Compagnie n° 512106824) dont le siège social est adressé au Parc Industriel Teradion, M.P. Misgav 2017400, Israël ("Canopia") garantit que le produit est exempt de tout défaut de matériau ou de fabrication pendant une période de 15 ans à compter de la date d'achat initiale. • Cette garantie n'est valable que si le produit est installé, manipulé, nettoyé et entretenu conformément aux spécifications établies par écrit de Canopia. • Cette garantie ne couvre pas les défauts résultant de l'usure normale, y compris, mais sans s'y limiter, les suivants : dommages causés par le forçage du produit, une mauvaise manipulation, une utilisation incorrecte, la négligence, les accidents, l'impact de corps étrangers, le vandalisme, les contaminants, les modifications, l'application de peinture, le nettoyage avec des détergents incompatibles ou les modifications mineures du produit. • Cette garantie ne s'applique pas aux dommages résultant de "catastrophes naturelles", y compris, mais sans s'y limiter, la grêle, les tempêtes, les tornades, les ouragans, les blizzards, les inondations ou les incendies. • Sur présentation de la preuve d'achat du Produit ainsi que de la preuve de la défaillance alléguée, et à condition que vous signaliez la défaillance par écrit dans les 30 jours suivant la découverte du défaut, Canopia remplacera, à sa seule discrétion, les pièces défectueuses du produit ou vous remboursera une partie proportionnelle du prix d'achat sur une base d'amortissement linéaire pour la durée de la garantie.

DE

15 JAHRE BESCHRÄNKTE GARANTIE VON PALRAM - CANOPIA

Palram Canopia Ltd. (Firmennummer: 512106824) mit Sitz in Teradion Industrial Park, M.P. Misgav 2017400, Israel („Canopia“) garantiert, dass das Produkt für einen Zeitraum von 15 Jahren ab dem ursprünglichen Kaufdatum frei von Material- und Verarbeitungsfehlern ist. • Diese Garantie ist nur gültig, wenn das Produkt gemäß den schriftlichen Spezifikationen von Canopia installiert, behandelt, gereinigt und gewartet wird. • Diese Garantie deckt keine Defekte ab, die auf normalen Verschleiß zurückzuführen sind, einschließlich, aber nicht beschränkt auf: Schäden, die durch Gewaltanwendung, falsche Handhabung, unsachgemäßen Gebrauch, Fahrlässigkeit, Unfälle, Einwirkungen von Fremdkörpern, Vandalismus, Schadstoffe, Veränderungen, Anstriche, Schäden, die durch Reinigung mit unverträglichen Reinigungsmitteln entstanden sind, oder geringfügige Abweichungen des Produkts. • Diese Garantie gilt nicht für Schäden, die durch „höhere Gewalt“ entstanden sind, wie z. B. Hagel, Sturm, Tornado, Orkan, Schneesturm, Überschwemmung oder Feuer. • Bei Einreichung des Kaufbelegs und des Nachweises des beanstandeten Produktfehlers und vorbehaltlich der schriftlichen Meldung des Fehlers innerhalb von 30 Tagen nach Entdeckung des Fehlers ersetzt Canopia nach eigenem Ermessen die fehlerhaften Teile des Produkts oder erstattet Ihnen einen anteiligen Teil des Kaufpreises auf linearer Abschreibungsbasis für die Dauer der Garantie.

ES

GARANTÍA LIMITADA DE 15 AÑOS DE PALRAM - CANOPIA

Palram Canopia Ltd. (Número de la compañía: 512106824) cuya oficina registrada se encuentra en Teradion Industrial Park, M.P. Misgav 2017400, Israel ("Canopia") garantiza que el producto estará libre de defectos de material o de fabricación durante un periodo de 15 años a partir de la fecha inicial de compra. • Esta garantía solo es válida si el producto se instala, manipula, limpia y mantiene de acuerdo con las especificaciones por escrito de Canopia. • Esta garantía no cubre los defectos resultantes del desgaste normal, entre lo que se incluye, entre otras cosas, lo siguiente: daños causados al forzar el producto, al manipularlo de forma incorrecta, al emplearlo de forma inapropiada, por negligencia, por accidentes, por impactos de objetos extraños, por vandalismo, por contaminantes, por modificaciones, por haber sido pintado, por la limpieza con detergentes incompatibles o por pequeñas modificaciones del producto. • Esta garantía no se aplica a los daños que resulten de "fenómenos naturales", lo que incluye, pero no se limita, al granizo, las tormentas, los tornados, los huracanes, las ventiscas, las inundaciones o los incendios. • Al presentar el comprobante de compra del producto así como una prueba de la falla que se reclama, y a condición de reportar la falla por escrito dentro de los 30 días siguientes al descubrimiento del defecto, Canopia, a su sola discreción, sustituirá las partes defectuosas del Producto, o le reembolsará una porción prorrateada del precio de compra de acuerdo a una base de depreciación lineal según la duración de la garantía.

SV

BEGRÄNSNINGAR I PALRAM - CANOPIA 15-ÅRS GARANTI

Palram Canopia Ltd. (Bolagsnummer: 512106824) vars registrerade huvudkontor har adressen: Teradion Industrial Park, M.P. Misgav 2017400, Israel ("Canopia") garanterar att produkten är fri från material- och tillverkningsfel under en period av 15 år från det ursprungliga inköpsdatumet. • Garantin gäller endast om produkten installeras, hanteras, rengörs och underhålls i enlighet med Canopias skriftliga specifikationer. • Garantin täcker inte defekter som beror på normalt slitage, inklusive, men inte begränsat till skador som orsakats av våld, felaktig hantering, olämplig användning, vårdslöshet, olyckor, påverkan från främmande föremål, vandalism, föroreningar, ändring, målning, skador som orsakats av rengöring med inkompatibla rengöringsmedel eller smärre avvikelser av produkten. • Denna garanti gäller inte för skador till följd av "naturkatastrofer", vilket inkluderar men inte är begränsat till hagel, storm, tornado, orkan, snöstorm, översvämning eller brand. • Mot uppvisande av inköpsbevis och bevis för det påstådda produktfelet, och under förutsättning att felet rapporteras skriftligen inom 30 dagar efter upptäckten av felet, kommer Canopia, efter eget gottfinnande, att byta ut defekta delar av produkten eller återbetala dig en proportionell del av inköpspriset på linjär avskrivningsbasis under garantins längd.

NN

PALRAM - CANOPIAS 15 ÅRS BEGRENSEDE GARANTI

Palram Canopia Ltd. (Selskapsnummer: 512106824) med hovedkontor i Teradion Industrial Park, M.P. Misgav 2017400, Israel ("Canopia") garanterer at produktet vil være uten defekter i materiale eller utførelse i en periode på 15 år fra den opprinnelige kjøpsdatoen. • Denne garantien gjelder bare hvis produktet er installert, håndtert, rengjort og vedlikeholdt i henhold til Canopias skriftlige spesifikasjoner. • Denne garantien dekker ikke feil som skyldes normal slitasje, inkludert, men ikke begrenset til: skade forårsaket av bruk av makt, feil håndtering, upassende bruk, uaktsomhet, ulykker, påvirkning fra fremmedlegemer, hærverk, miljøgifter, endring, maling, skade som følge av rengjøring med inkompatible vaskemidler eller mindre avvik i produktet. • Denne garantien gjelder ikke for skader som følge av naturfenomener, inkludert, men ikke begrenset til, hagl, storm, tornado, orkan, snøstorm, flom eller brann. • Ved innlevering av kvittering på kjøp og bevis på den påståtte produktfeilen, og med forbehold om skriftlig rapportering av feilen innen 30 dager etter oppdagelsen av feilen, vil Canopia, etter eget skjønn, erstatte defekte deler av produktet, eller refundere deg en del av kjøpesummen beregnet ved bruk av lineær metode på grunnlag av garantiens varighet.

PALRAM - CANOPIA FINNISH | 15 VUODEN RAJOITETUT TAKUUEHDOT

Palram Canopia Ltd. (yhtiön rek.nro 512106824) jonka päätoimipiste toimii osoitteessa Teradion Industrial Park, M.P. Misgav 2017400, Israel. ("Canopia") takaa, että tuotteesta ei ole materiaali- tai valmistusvirheitä 15 vuoden ajan alkuperäisestä ostopäivästä. • Tämä takuu on voimassa vain, jos tuote on asennettu, sitä on käsitelty, puhdistettu ja huollettu Canopian kirjallisten ohjeiden mukaisesti. • Tämä takuu ei kata vikoja, jotka johtuvat normaalista kulumisesta, mukaan lukien mutta rajoittumatta: voimankäytöstä aiheutuneet vahingot, väärä käsittely, sopimaton käyttö, huolimattomuus, onnettomuudet, vierasesineiden törmäykset, ilkkivalta, saasteet, muutokset, maalaus, vauriot jotka johtuvat puhdistuksesta yhteensopimattomilla pesuaineilla, tai tuotteen vähäisestä poikkeamisesta. • Tämä takuu ei koske vaurioita, jotka johtuvat luonnonvoimista, joihin kuuluvat muun muassa rakeet, myrsky, tornado, hurrikaani, lumimyrsky, tulva tai tulipalo. • Canopia oman harkintansa mukaan vaihtaa vialliset tuotteen osat tai palauttaa sinulle tuotteen vialliset osat toimitettuasi ostotodistuksen ja todisteet väitetystä tuotteen viasta ja ilmoittamalla virheestä kirjallisesti 30 päivän kuluessa vian havaitsemisesta, tai hyvittää sinulle suhteellisen osuuden ostohinnasta laskettuna tasapainotoina kuluneen takuuajan mukaisesti.

FI

PALRAM - CANOPIAS DANISH | 15 ÅRS BEGRÆNSET GARANTI

Palram Canopia Ltd. (Virksomhedsregistreringsnummer: 512106824), registreret på adressen Teradion Industrial Park, M.P. Misgav 2017400, Israel ("Canopia"), garanterer, at produktet vil være uden defekter i materiale eller udførelse i en periode på 15 år fra den oprindelige købsdato. • Denne garanti gælder kun, hvis produktet er installeret, håndteret, rengjort og vedligeholdt i overensstemmelse med Canopias skriftlige specifikationer. • Denne garanti dækker ikke defekter, der skyldes normal slitage, herunder, men ikke begrænset til: skader forårsaget af magtanvendelse, forkert håndtering, forkert brug, uagtsomhed, ulykker, udsættelse for fremmedlegemer, hærværk, miljøgifte, ændring, maling, skader som følge af rengøring med uforenelige rengøringsmidler eller mindre afvigelser i produktet. • Denne garanti dækker ikke skader som følge af naturfænomenener, herunder, men ikke begrænset til, hagl, storm, tornado, orkan, snestorm, oversvømmelse eller brand. • Ved fremsendelse af en kvittering for køb og bevis for den påståede produktfejl, og med forbehold for skriftlig indberetning af defekten inden for 30 dage efter opdagelsen af defekten, vil Canopia efter eget skøn udskifte defekte dele af produktet, eller refundere dig en del af købsprisen beregnet ved hjælp af den lineære metode på grundlag af garantiens varighed.

DA

PALRAM - CANOPIA'S DUTCH | 15 JAARS BEPERKTE GARANTIE

Palram Canopia Ltd. (Bedrijfsnummer: 512106824) met maatschappelijke zetel te Teradion Industrial Park, M.P. Misgav 2017400, Israël ("Canopia") garandeert dat het product vrij zal zijn van materiaal- of fabricagefouten gedurende een periode van 15 jaar vanaf de oorspronkelijke aankoopdatum. • Deze garantie is alleen geldig als het product wordt geïnstalleerd, gehanteerd, gereinigd en onderhouden in overeenstemming met de schriftelijke specificaties van Canopia. • Deze garantie dekt geen defecten die het gevolg zijn van normale slijtage, waaronder, maar niet beperkt tot schade veroorzaakt door het gebruik van geweld, onjuist gebruik, nalatigheid, ongevallen, impact van vreemde voorwerpen, vandalisme, verontreinigende stoffen, wijziging, beschadiging, schade als gevolg van reiniging met onverenigbare detergentia of kleine afwijkingen van het product. • Deze garantie is niet van toepassing op schade die het gevolg is van "natuurrampen", waaronder maar niet beperkt tot hagel, storm, tornado, orkaan, sneeuwstorm, overstroming of brand. • Na het indienen van het aankoopbewijs en het bewijs van het geclaimde productfalen, en onder voorbehoud van het schriftelijk melden van het falen binnen 30 dagen na ontdekking van het defect, zal Canopia, naar eigen goeddunken, defecte onderdelen van het product vervangen of u een pro rata deel van de aankoopprijs terugbetalen op een lineaire afschrijvingsbasis voor de duur van de garantie.

NL

GARANZIA LIMITATA 15 ANNI | PALRAM - CANOPIA

Palram Canopia Ltd. (società numero: 512106824) i cui uffici registrati hanno sede a Teradion Industrial Park, M.P. Misgav 2017400, Israele ("Canopia") garantisce che il prodotto è privo di difetti di materiale o di lavorazione per un periodo di 15 anni dalla data di acquisto iniziale. • La garanzia è valida solo se il prodotto viene installato, trattato, pulito e sottoposto a manutenzione in conformità alle specifiche scritte di Canopia. • Questa garanzia non copre i difetti derivanti dalla normale usura, inclusi, ma non solo, i seguenti: danni causati da forzature del prodotto, uso improprio, negligenza, incidenti, impatto di oggetti estranei, vandalismo, contaminazione, modifiche, verniciatura, pulizia con detergenti incompatibili o modifiche minori del prodotto. • Questa garanzia non si applica ai danni derivanti da "cause di forza maggiore", tra cui, a titolo esemplificativo, grandine, tempeste, tornado, uragani, bufere, inondazioni o incendi. • Su presentazione della prova d'acquisto del Prodotto e della prova del presunto guasto, e a condizione che lei denunci il guasto per iscritto entro 30 giorni dalla scoperta del difetto, Canopia, a sua esclusiva discrezione, sostituirà le parti difettose del Prodotto o rimborserà una parte proporzionale del prezzo d'acquisto sulla base di un ammortamento lineare per la durata della garanzia.

IT

15-ROČNÁ OBMEDZENÁ ZÁRUKA | PALRAM - CANOPIA

Palram Canopia Ltd. (číslo spoločnosti: 512106824), ktorej sídlo je v priemyselnom parku Teradion, M.P. Misgav 2017400, Izrael ďalej len („Canopia“) zaručuje, že výrobok bude bez väd materiálu alebo spracovania po dobu 15 rokov od pôvodného dátumu nákupu. • Táto záruka platí len vtedy, ak je výrobok namštalovaný, je s ním manipulované, je čistený a udržiavaný v súlade s písomnými špecifikáciami spoločnosti Canopia. • Táto záruka sa nevzťahuje na chyby vyplývajúce z bežného opotrebovania vrátane, ale nie výlučne: poškodenie spôsobené použitím sily, nesprávnou manipuláciou, nevhodným používaním, nedbalosťou, nehodami, nárazom cudzích predmetov, vandalizmom, znečisťujúcimi látkami, úpravou, náterom, poškodením v dôsledku čistenia nekompatibilnými čistiacimi prostriedkami alebo drobnými odchýlkami výrobu. • Táto záruka sa nevzťahuje na škody spôsobené "prírodnými udalosťami", ktoré zahŕňajú okrem iného krupobitie, búrku, tornádo, hunkán, víchricu, povodeň alebo požiar. • Po predložení dokladu o kúpe a dôkazu o reklamovanej poruche výrobku a na základe písomného nahlásenia poruchy do 30 dní od zistenia poruchy vám spoločnosť Canopia podľa vlastného uváženia vymení chybné časti výrobku alebo vám vráti pomernú časť kúpnej ceny na základe rovnomerného odpisovania počas trvania záruky.

SK

15-LETNA OMEJENA GARANCIJA PODJETJA | PALRAM - CANOPIA

Podjetje Palram Canopia Ltd. (matična številka: 512106824), katerega sedež je na naslovu Teradion Industrial Park, M.P. Misgav 2017400, Izrael podjetje ("Canopia"), jamči, da bo izdelek brez napak v materialu ali izdelavi za obdobje 15 let od prvotnega datuma nakupa. • Ta garancija velja le, če je izdelek nameščen, obdelan, očiščen in vzdrževan v skladu s pisnimi specifikacijami podjetja Canopia. • Ta garancija ne krije napak, ki so posledica običajne obrabe, vključno, vendar ne omejeno na škodo, ki jo povzroči uporaba sile, nepravilno ravnanje, neprimerno uporabo, malomarnost, nesreče, udarce tujih predmetov, vandalizem, onesnaževala, spremembe, barvanje, škodo, ki je posledica čiščenja z nezdržljivimi detergenti ali manjša odstopanja izdelka. • Ta garancija ne velja za škodo, ki izhaja iz "naravnih pojavov", ki vključuje, vendar ni omejena na točo, nevihto, tornado, orkan, snežni metež, poplavo ali požar. • Po predložitvi dokazila o nakupu in dokazila o zatrtjevanju napaki izdelka ter ob pisni prijavi napake v 30 dneh po odkritju napake bo Palram - Canopia po lastni presoji zamenjal okvarjene dele izdelka ali vam povrni sorazmerni delež nakupne cene po metodi enakomernega časovnega amortiziranja za čas trajanja garancije.

SL

ET
PALRAM - CANOPIA | 15 - AASTANE PIIRATUD GARANTII

Palram Canopia Ltd (Ettevõtte number 512106824), kelle registrijärge asukoht on Teradion Tööstuspargis, M. Misgav 2017400, Iisrael („Canopia“) annab garantii, et tootel ei esine materjali- ega tootmisdefekte 15 aasta jooksul alates esialgsest ostukuupäevast.

- Käesolev garantii on kehtiv ainult juhul, kui toode on paigaldatud, seda on käsitsetud, puhastatud ja hooldatud vastavalt Canopia kirjalikele spetsifikatsioonidele.
- Käesolev garantii ei kata defekte, mis on tingitud tavapärasest kulumisest, sealhulgas, kuid mitte ainult: jõu kasutamisest põhjustatud kahjustused, ebaõige käsitsemine, sobimatu kasutamine, hooletus, õnnetused, kokkupuude võõrkehaga, vandalism, saasteained, muudatused toote juures, värvimine, kahjustused tingituna kokkusobimatute pesuvahenditega puhastamisest või toote väiksematest kõrvalekalletest.
- Käesolev garantii ei kehti kahjustustele, mis on põhjustatud „loodusjõust“, mis hõlmab, kuid ei piirdu järgnevaga: rahe, torm, tornado, orkaan, lumetorm, üleujutus ja tulekahju.
- Ostutõendi ja toote väidetava rikke kohta tõendite esitamisel ning juhul, kui tõrkest on kirjalikult teatatud 30 päeva jooksul pärast defekti avastamist, asendab Canopia oma diskretsioonile tuginedes toote defektsed osad või tagastab teile tagastab teile garantijaia jooksul proportsionaalse osa ostuhinnast, võttes lineaarselt arvesse toote amortisatsiooni

HU
A PALRAM - CANOPIA | 15 ÉVES KORLÁTOZOTT JÓTÁLLÁSA

A Palram Canopia Kft. (cégyezékszám: 512106824), amelynek székhelye a Teradion Industrial Park, MP Misgav 2017400, Izrael (a továbbiakban: „Canopia“), a vásárlás időpontjától számítva 15 évig garantálja, hogy a termék nem tartalmaz anyag- vagy egyéb gyártási hibákat.

- Ez a garancia kizárólag akkor érvényes, ha a terméket a Canopia által írásban foglalt előírásainak megfelelően telepítették, kezelték, tisztították és tartották karban.
- Ez a garancia nem terjed ki a szokásos elhasználódásból eredő hibákra, beleértve, de nem kizárólagosan a következőket: Olyan károkat, amelyeket nem megfelelő, erőszakos használat, helytelen kezelés, nem rendeltetésszerű használat, gondatlanság, baleset, idegen tárgyak által okozott sérülések, vandalizmus, szennyeződések, átalakítás, festés, nem megfelelő tisztítószerrel történő tisztítás, vagy a termék akár kismértékű megváltozása okoz.
- A garancia nem vonatkozik a "természeti eredetű" károokra, ideértve többek között az erős jégesőt, vihart, tornádót, hurrikánt, hóvihart, árvizet vagy tüzeset.
- A Canopia a vásárlást igazoló bizonylat és a termék meghibásodására vonatkozó bizonylatk benyújtása esetén, valamint a hiba észlelésétől számított 30 napon belül írásban benyújtott kárbejelentés esetén, saját belátása szerint kicseréli a termék hibás részeit, vagy a garancia időtartamának megfelelő, értékcsökkenéssel arányos részét visszatéríti Önnek.

PL
GWARANCJA PALRAM - CANOPIA OGRANICZONA NA 15 LAT

Palram Canopia Ltd. (Numer firmy: 512106824) której zarejestrowane biuro znajduje się w Teradion Industrial Park, M.P Misgav 2017400, Izrael („Canopia“) gwarantuje, że produkt będzie wolny od wad materiałowych lub produkcyjnych przez okres 15 lat od daty zakupu.

- Gwarancja jest ważna jedynie wtedy, gdy produkt jest instalowany, obsługiwany, czyszczony i konserwowany zgodnie z pisemną dokumentacją firmy Canopia.
- Gwarancja nie obejmuje wad spowodowanych normalnym użytkowaniem eksploatacyjnym, takich jak uszkodzenia wynikające z użycia siły, nieprawidłowej obsługi, nieprawidłowego korzystania, zaniedbania, wypadku, uderzenia przez ciało obce, aktu wandalizmu, działania polutantów, modyfikacji, malowania, czyszczenia za pomocą nieodpowiednich detergentów lub niewielkich odchylen produktu.
- Gwarancja nie obejmuje również uszkodzeń spowodowanych „siłami przyrody“, takimi jak grad, burza, tornado, huragan, śnieżyca, powódź lub ogień.
- Po przesłaniu potwierdzenia zakupu oraz dowodu wskazującego wadę produktu i zgłoszeniu tej wady na piśmie w terminie 30 dni od chwili jej wykrycia Canopia wymieni wadliwe części produktu lub dokona zwrotu kwoty odpowiadającej proporcjonalnej części ceny zakupu w oparciu o zasadę amortyzacji liniowej, w okresie obowiązywania gwarancji i według własnego uznania.

LT
PALRAM - CANOPIA | 15 GADU IEROBEŽOTĀ GARANTĪJA

Firma Palram Canopia Ltd. (Uznēmuma numurs. 512106824), kura juridiskā adrese ir Teradion Industrial Park, M.P Misgav 2017400, Izraēla („Canopia“) sākot no iegādes datuma, izsniedz 15 gadu garantiju, nodrošinot, ka iegādātajam Produktam nebūs nedz rzejmateriāla, nedz arī ražošanas bojājumu.

- Izsniegtā garantija ir spēkā tikai un vienīgi tad, ja Produkts ir uzstādīts, tīrīts, kopts un izmantots tieši tā, kā tas tiek aprakstīts Canopia rokasgrāmatā.
- Šī garantija neattiecas uz tādiem bojājumiem, kas radušies ikdienas nolietojuma rezultātā, tostarp, bet ne tikai: bojājumiem, kas radušies pārliela spēka pielietošanas rezultātā, nepareizas vai neatbilstīgas lietošanas dēļ, nolaidības; negadījuma rezultātā; trieciena, vandālisma vai piesārņojuma rezultātā; pārkrāsošanas vai patvaļīgas produkta pārveides dēļ; bojājumiem, kas radušies, apstrādājot produktu ar neatbilstošiem tīrīšanas līdzekļiem. Garantija neattiecas uz maznozīmīgām atskirībām Produkta aprakstā.
- Šī garantija nesedz tādu bojājumu, kas radušies dabas katastrofu rezultātā,- tostarp, bet ne tikai: kravas, vētras, viesuļvētras, tornado, sniegpūtens, plūdi vai ugunsgrēka gadījumā. Lai saņemtu garantiju, 30 dienu laikā pēc Produkta bojājuma atklāšanas lūdzam rakstiskā veidā pazinot par bojājuma veidu, pievienojot Pretenzijai pirkuma apliecināšo dokumentu.
- Firma "Palram Canopia Ltd" pēc saviem ieskatiem nomainīs bojātās Produkta daļas vai arī atmaksās naudas summu, kas ir proporcionāla pirkuma cenai, - ņemot vērā garantijas laiku un Produkta proporcionālo nolietojumu.

CS
15 LETÁ OMEZENÁ ZÁRUKA PALRAM - CANOPIA

Palram Canopia Ltd. (Společnost číslo. 512106824), jejíž registrační kancelář je na adrese Teradion Industrial Park, M.P Misgav 2017400, Izrael („Canopia“), zaručuje, že produkt bude bez vad materiálu nebo zpracování po dobu 15 let od původního data nákupu.

- Tato záruka je platná pouze v případě, že je produkt instalován, manipulován, čištěn a udržován v souladu s psanými specifikacemi společnosti Canopia.
- Tato záruka se nevztahuje na vady způsobené běžným opotřebením, mimo jiné: poškození způsobené použitím síly, nesprávnou manipulací, nevhodným použitím, nedbalostí, nehodami, nárazem cizích předmětů, vandalizmem, znečišťujícími látkami, úpravami, lakováním, poškozením z důsledku čistění nekompatibilními čisticími prostředky nebo drobnými odchylkami výrobku.
- Tato záruka se nevztahuje na škody vzniklé v důsledku „přirodních činů“, které zahrnují, ale nejsou omezeny na krupobití, bouři, tornádo, hunkán, vánici, povodeň nebo požár.
- Canopia, po předložení dokladu o koupi a dokladu o reklamované závadě výrobku a pod podmínkou písemného nahlášení závady do 30 dnů od zjištění závady, dle vlastního uvážení vymění vadné části produktu nebo vám vrátí poměrnou část kupní ceny na základě rovnoměrného odepisování po dobu záruky.

HR
PALRAM - CANOPIA | 15 GODINA OGRANIČENO JAMSTVO

Palram Canopia Ltd (Broj tvrtke: 512106824) čiji je sjedište u industrijskom parku Teradion, M.P Misgav 2017400, Izrael („Canopia“) jamči, da će proizvod biti bez grešaka u materijalu ili izradi u razdoblju od 15 godina, od prvobitnog datuma kupnje.

- Ovo jamstvo vrijedi samo ako se proizvod instalira, rukuje, čisti i održava u skladu s pisanim specifikacijama tvrtke Canopia.
- Ovo jamstvo ne pokriva greške, koji proizlaze iz uobičajenog trošenja uključujući, ali ne ograničavajući se na: štetu uzrokovanu uporabom sile, nepravilnim rukovanjem, neprikladnom uporabom, nemarkom, nesrećama, udarcima stranih tijela, vandalizmom, zagadivačima, izmjenama, bojanjem, oštećenjem, koji je rezultat čišćenja nekompatibilnim deterdžentima ili manjih odstupanja proizvoda.
- Ovo se jamstvo ne odnosi na štetu koja je posljedica "prirodnih djelova", što uključuje, ali nije ograničeno na tuču, oluju, tornado, uragan, mećavu, poplavu ili požar.
- Nakon podnošenja dokaza o kupnji i dokaza o navedenom kvaru proizvoda, te uz prijavu kvara u pisanom obliku u roku od 30 dana nakon otkrivanja kvara, Canopia će prema vlastitom nahođenju, zamijeniti neispravne dijelove proizvoda ili vratiti novac proporcionalni dio nabavne cijene na osnovi linearne amortizacije tijekom trajanja jamstva.

RU

PALRAM - CANOPIA | 15 лет ограниченной гарантии

Palram Canopia Ltd. (номер компании: 512106824), юридический адрес: Teradion Industrial Park, M.P. Misgav 2017400, Israel («Canopia») гарантирует, что в течение 15 лет с исходной даты покупки продукт не будет иметь дефектов изготовления и материалов. • Данная гарантия имеет силу только, если продукт был установлен, обрабатывался, очищался и обслуживался согласно письменным указаниям Canopia. • Данная гарантия не покрывает дефекты, возникшие в результате нормальной эксплуатации, включая, но не ограничиваясь следующим: повреждения, полученные в результате применения силы, нарушение правил эксплуатации, использование не по назначению, халатное отношение, аварийная ситуация, воздействие посторонних объектов, умышленная порча, загрязнение, переделка, покраска, повреждения, полученные в результате очистки несовместимыми моющими средствами или небольшие отклонения продукта. • Данная гарантия не покрывает повреждения, полученные в результате природных катаклизмов, включая, но не ограничиваясь следующим: град, шторм, торнадо, ураган, снежная буря, наводнение или пожар. • После предъявления доказательства покупки, подтверждения заявленного дефекта продукта и письменного сообщения о дефекте в течение 30 дней после обнаружения дефекта, Canopia по своему усмотрению, заменит дефектные части продукта или выплатит пропорциональную часть цены покупки на основе равномерной амортизации на период действия гарантии.

RO

PALRAM - CANOPIAS | GARANȚIE LIMITATA DE 15 ANI

Palram Canopia Ltd (Companie Nr. 512106824) cu sediul la Parcul Industrial Teradion, oficiul poștal mobil Misgav 2017400, Israel (în continuare „Canopia”) garantează că produsul va fi menținut fără defecte de material sau de folosire pentru o perioadă de 15 ani de la data inițială de cumpărare. • Această garanție este valabilă numai dacă produsul este instalat, folosit, curățat și întreținut în conformitate cu specificațiile prescrise de Canopia. • Această garanție nu acoperă defectele rezultate de la uzura normală, inclusiv, dar fără a se limita: daune cauzate de folosirea forței, folosirea incorectă, utilizarea inadecvată, neglijență, accidente, impact de la obiecte străine, vandalism, poluanți, alterare, vopsire, daune rezultate din curățare cu detergenți incompatibili sau distorsiuni minore ale produsului. • Această garanție nu este aplicabilă daunelor rezultate din „acte ale naturii”, care includ, dar fără a se limita: grindină, furtună, tornado, uragan, viscol, inundație sau incendiu. • La trimiterea dovezii de cumpărare și a dovezii de defectune a produsului revendicat, și sub rezerva raportării defectunii, în scris, în termen de 30 de zile de la descoperirea defectului reclamat, Compania Canopia, la propria sa discreție, va înlocui părțile defecte ale produsului sau vă va rambursa o parte proporțională din prețul de achiziție, pe bază de amortizare liniară, pentru durata garanției.

HE

אחריות מוגבלת ל-15 שנים של PALRAM - CANOPIA

Palram Canopia Ltd. (מ.פ. 512106824), אשר משרדיה נמצאים בפארק תעשיות תרדיון, ד.ג. משגב 2017400, ישראל ("Canopia") מתחייבת כי המוצר יהיה ללא כל פגם מבחינת החומר והעבודה למשך תקופה של 15 שנים החל מתאריך הרכישה הראשון. • אחריות זו תהיה בתוקף אך ורק עם המוצר יותקן, יטופל, ינוקה, יתוחזק בהתאם להנחיות הכתובות של Canopia. • אין אחריות זו מכסה פגמים כתוצאה מכליה רגילה וקריעה, אך גם נזק שנגרם משימוש בכוון, טיפול לא נכון, שימוש לא הולם, הזנחה, תאונות, פגיעה על ידי גופים זרים, ונדליות, מזהמים, שינויים, צביעה, נזק שנגרם כתוצאה מניקוי באמצעות דטרגנטים לא מתאימים או סטיות קלות של המוצר. • אין אחריות זו מכסה נזק שנגרם מ"כוחות הטבע", הכוללים בין השאר אך לא רק, ברד, סערה, טורנדו, הוריקן, סופת שלגים, שטפון, או אש. • בעת הגשת הכחשת רכישה ועדות לכשל של המוצר, ובכפוף לדיווח בכתב על הכשל תוך 30 יום מהתאריך בו התגלה הפגם, Canopia, בהתאם לשיקול דעתה הבלעדי, תחליף את החלקים הפגומים של המוצר, או תחזיר את החלק היחסי של מחיר הרכישה על בסיס של פחת בשיטת הקו הישר לאורך תקופת האחריות.

LIT

ĮRENGINIUI TAIKOMA 15 METŲ RIBOTOS ATSAKOMYBĖS GARANTIJA | PALRAM - CANOPIA

„Palram Canopia Ltd.“ (Įmonės kodas: 512106824), kurios registruota buveinė yra Teradion Industrial Park, M.P. Misgav 2017400, Izraelis („Canopia“) suteikia produktui 15 metų garantiją dėl medžiagų ar gamybos defektų nuo pradinės pirkimo datos. • Ši garantija galioja tik tuo atveju, jei produktas yra sumontuotas, tvarkomas, valomas, ir prižiūrimas pagal rašytines „Canopia“ technines sąlygas. • Ši garantija netaikoma defektams, atsiradusiems dėl įprasto nusidėvėjimo, įskaitant, bet neapsiribojant: žałą, padarytą naudojant jėgą, netinkamą elgesį, netinkamą naudojimą, aplaidumą, nelaimingus atsitikimus, pašalinų daiktų poveikį, vandalizmą, teršalus, pakeitimus, dažymą, žałą, atsiradusią dėl valymo nesuderinamais plovikliais, arba nedidelius produkto nukrypimus. • Ši garantija netaikoma žalai, atsiradusiai dėl „gamtos veiksmy“, įskaitant krušą, audrą, tornadą, uraganą, pūgą, potvynį ar gaisrą, bet tuo neapsiribojant. • Pateikusi pirkimo įrodymą ir įrodymus, patvirtinančius, kad produktas yra sugedęs, ir apie gedimą raštu pranešus per 30 dienų nuo defekto nustatymo, „Canopia“ savo nuožiūra pakeis nekokybiškas produkto dalis arba grąžins jums proporcingą pirkimo kainos dalį, taikant tiesinį nusidėvėjimą garantijos laikotarpiui.